

**The COMET Range of Boilers**  
the ultimate solution for central heating

**INSTALLATION**  
**&**  
**TECHNICAL MANUAL**

*Fusion*



**Comet**

***ehc***

the electric heating company

**If you require any further assistance:**

**Telephone: 01698 820533**

**Fax: 01698 825697**

**E-mail: [info@electric-heatingcompany.co.uk](mailto:info@electric-heatingcompany.co.uk)**  
**or visit our website [www.electric-heatingcompany.co.uk](http://www.electric-heatingcompany.co.uk)**



## Page Contents

INTRODUCTION	2
PREPARATION	3
INSTALLATION	4
ELECTRICAL CONNECTIONS AND CONTROLS	8
EXTERNAL CONTROL WIRING	10
CONTROL PANEL CONNECTIONS	11
EXTERNAL BOILER WIRING	12
BOILER DIMENSIONS	12
USER INSTRUCTIONS	14
FAULT FINDING	15
TECHNICAL SPECIFICATIONS	15

**This appliance is not intended for use by persons (including children) with reduced physical, sensory or mental capabilities, or lack of experience and knowledge, unless they have been given supervision or instruction concerning use of the appliance by a person responsible for their safety.**

**Children should be supervised to ensure that they do not play with the appliance.**

## INTRODUCTION

Please read and follow the installation and operating instructions carefully, to ensure the long life and reliable operation of this appliance.

The Electric Heating Company may make minor changes if necessary in the appliance that will not be shown in the operating instructions, so long as the main features of the boiler remain the same.

All boilers come with a 24 month warranty that covers all defects originating from faulty materials and workmanship in the manufacture of the boilers.

The warranty covers the replacement of any faulty parts and labour costs.

The warranty will not cover any damage to the boiler from poor or incorrect installation work.

The warranty will not cover any call out charges that have not been organised by the Electric Heating Company Ltd.

The warranty will not cover water leaks into the boiler. All plumbing joints must be checked.

The warranty card must be completed and sent back to The Electric Heating Company as soon as possible for registration.

An internal Magnetic Filter is fitted to the Boiler and it must be cleaned at least annually. (Note: Failure to clean the Magnetic Filter may result in boiler shutdown). Warranty calls will not be covered for this repair.

# PREPARATION

## Instructions and Building Regulations

This appliance must be fitted in accordance with the following instructions.

The Local Building Regulations

The Building Regulations

The Building Standards, (Scotland-consolidated) Regulations.  
Local water bylaws. British Standards- code of practice

### **BS EN 12828:2003**

Heating systems in buildings. Design for water-based heating systems.

### **BS EN 12831:2003**

Heating systems in buildings. Method for calculation of the design heat load

### **BS EN 14336:2004**

Heating systems in buildings. Installation and commissioning of water based heating systems

### **BS 7671:2008**

Requirements for electrical installations. IEE Wiring Regulations. Seventeenth edition.

### **BS EN 13831:2007**

Closed expansion vessels with built-in diaphragm for installation in water

## C.O.S.H.H.

Materials used in the manufacture of this appliance are non-hazardous and no special precautions are required when fitting or servicing this appliance.

## PREPARATION

### 1. Load Check

A load check should be taken into consideration when installing high output boilers.

### 2. Boiler location

The boiler must be fitted on a wall that will provide an adequate fixing, and should be fitted in a location that the boiler and pipe-work are not subject to frost and damp conditions.

### 3. Central heating (design & installation)

Detailed recommendations are given in BS EN 12828:2003, BS 6700: 2006+A1: 2009 and CP 342-2:1974

Pipes forming part of the useful heating surface should be insulated to prevent any potential heat loss or frost damage (BS 6700:1997).

Drain valves should be fitted at the lowest point of the system pipe work in an accessible position.

Drain valves should be in accordance with BS 2879: 1980 and copper tube to BS EN 1057: 1996. is recommended.

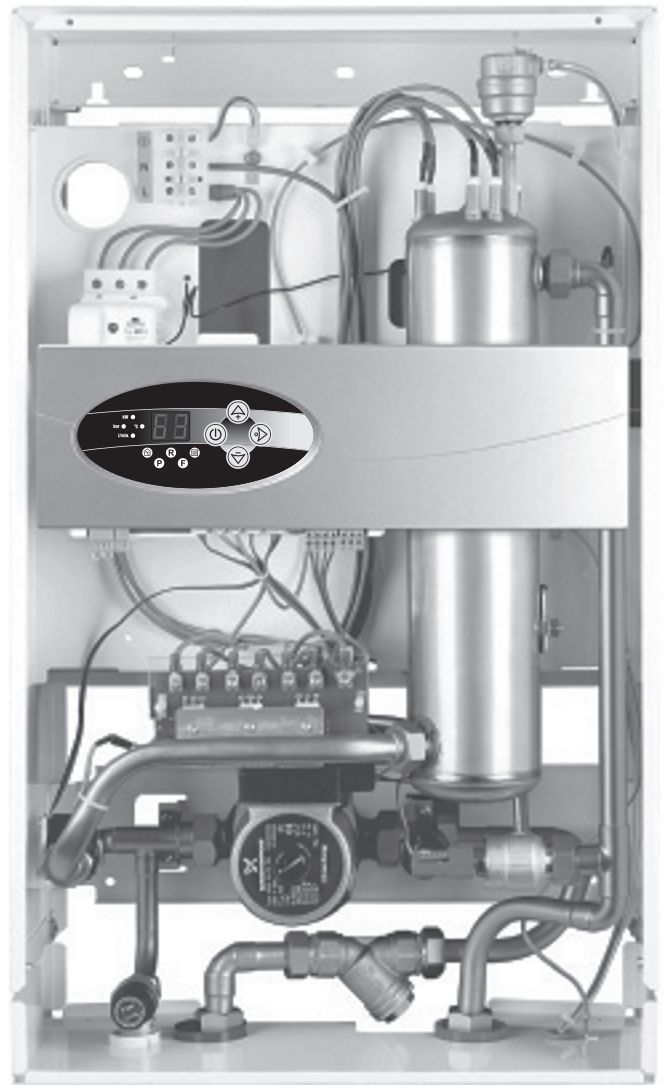

## LOCATION

The boiler can be installed in almost any location within a domestic or commercial property, however consideration should be given to future maintenance. Never leave the boiler switched off if there is danger of having temperatures below 0°C in the room where it is located.

We recommend that a minimum clearance of 450 mm should be allocated for the removal of the front cover and adequate access to the boiler plumbing and the internal electrical connections. A 50 mm allowance should be made at either side of the boiler to allow free flow air into the boiler case and allow access to screws on the boiler case.

**THE BOILER MUST BE INSTALLED IN THE UPRIGHT POSITION, FAILURE TO DO SO WILL INVALIDATE THE WARRANTY**

# INSTALLATION

## 1. General

The boiler must be installed by a professional plumber or heating engineer and must be connected to the public low voltage network by a competent person. For systems that require a three phase electrical supply we strongly recommend this is installed by a 17th Edition certified Electrical Engineer.

**The Electric Heating Company Ltd will not be held responsible for faulty installations which are performed by un-qualified tradespersons.**

## 2. Pipe Connections

All Fusion Electric Boilers have a 22mm compression connection at the boiler's flow and return pipes. Please note that the boilers are supplied with blank washers fitted for transit purposes. These must be removed before connections to pipe-work can be made.

The flow (red) and return (blue) are clearly marked on the external case and under no circumstances should these connections be reversed. Hot connections are not recommended at the boiler for future maintenance and boiler disconnection. Lockshield valves are recommended.

## 3. Case Removal

Remove outer screws at the bottom of the boiler and pull the front cover outwards taking care to remove internal earth connections. Earth connections must be re-connected before the boiler case is re-installed.

## 4. Isolation Valves

We recommend that lockshield isolation valves are fitted on the flow and return pipework. Such valves must be „full way“ and not 'ball valves.' The installation of „ball valves“ in the flow and return pipework will reduce the recommended flow rate through the boiler and promote premature boiler shutdown.

## 5. Auto air vents

An auto air vent is integral within the boiler however an additional auto air vent must be fitted at the cylinder coil if the boiler is being used for central heating and domestic hot water.

## 6. Boiler Sizing

Calculate the „space heating“ requirements in accordance with BS EN 12831 and BS EN 14336. If the boiler is to heat the domestic hot water, an additional allowance of 3kW (10,239 Btu's) should be made to the 'space heating' calculation.

## 7. Insulation

Where practical, and if at all possible, we recommend that all pipe-work be insulated, in particular the primary pipe-work with-in a boiler cupboard. This is to reduce heat loss and reduce high cupboard temperatures from exposed pipe-work. (BS 6700: 2006+A1: 2009).

## 8. System Design

The boiler has an integral automatic bypass valve fitted which should be set to the relevant settings to allow the minimum flow rates to pass through the boiler (8 l/min) when all radiator thermostats and zone valves are closed.

Allowance should be made for a radiator to be installed within the heating circuit and locked open. This will be located in the room that has the room thermostat installed.

To comply with building regulations, Part L and Part J (in Scotland), room and cylinder stats must be fitted.

## 9. Water Connections

**Provisions must be made for the replacement of water lost from the heating system (sealed systems).** Reference should be made to BS EN 14336 for the method of filling and make up of water.

There must be no direct connection between the boilers central heating system and the main water supply. When mains water is required to fill the system directly, all local water bylaws must be observed, and any connection made must be disconnected after use.

## 10. Flushing

When installing a new Boiler to existing radiators & pipework these items should be flushed before a new boiler is installed. New boiler installations also require to be flushed before boiler start up. This is to ensure that no debris is trapped in the flow sensor as this may result in boiler failure.

## 11. System pressures

All boilers are tested to 4.0 bar. The normal working pressure of the boiler should be set to approx 1.0 / 1.5 bar. All sealed systems should comply with the relevant building regulations and standards, including BS EN 13831 – Specification for Expansion Vessels.

### **Please Note:**

In order to protect the Flow Sensor located within the boiler, it is imperative that the pre-installed magnetic filter is removed and cleaned at least annually. Failure to carry out this action will increase contamination of the boiler by system residue.

# INSTALLATION

## ELECTRIC BOILER INTERNAL LAYOUT

- [1] - Stainless Steel Heat Exchanger
- [2] - Flow Sensor
- [3] - Pressure Sensor
- [4] - Safety Valve
- [5] - Circulating Pump
- [6] - Safety Temperature limiter
- [7] - Return connection
- [8] - Flow connection
- [9] - Power Board
- [10] - Control Module

- [11] - Automatic Vent
- [12] - Expansion Vessel and connection
- [13] - By-pass Valve
- [14] - Magnetic Filter
- PF - Internal „mains“ phase connections from the PN connection block
- PN - Incoming ‘mains’ cable connection block
- WP - Electric cable access
- M - Boiler fixing points
- RP - Room Thermostat volt free connection

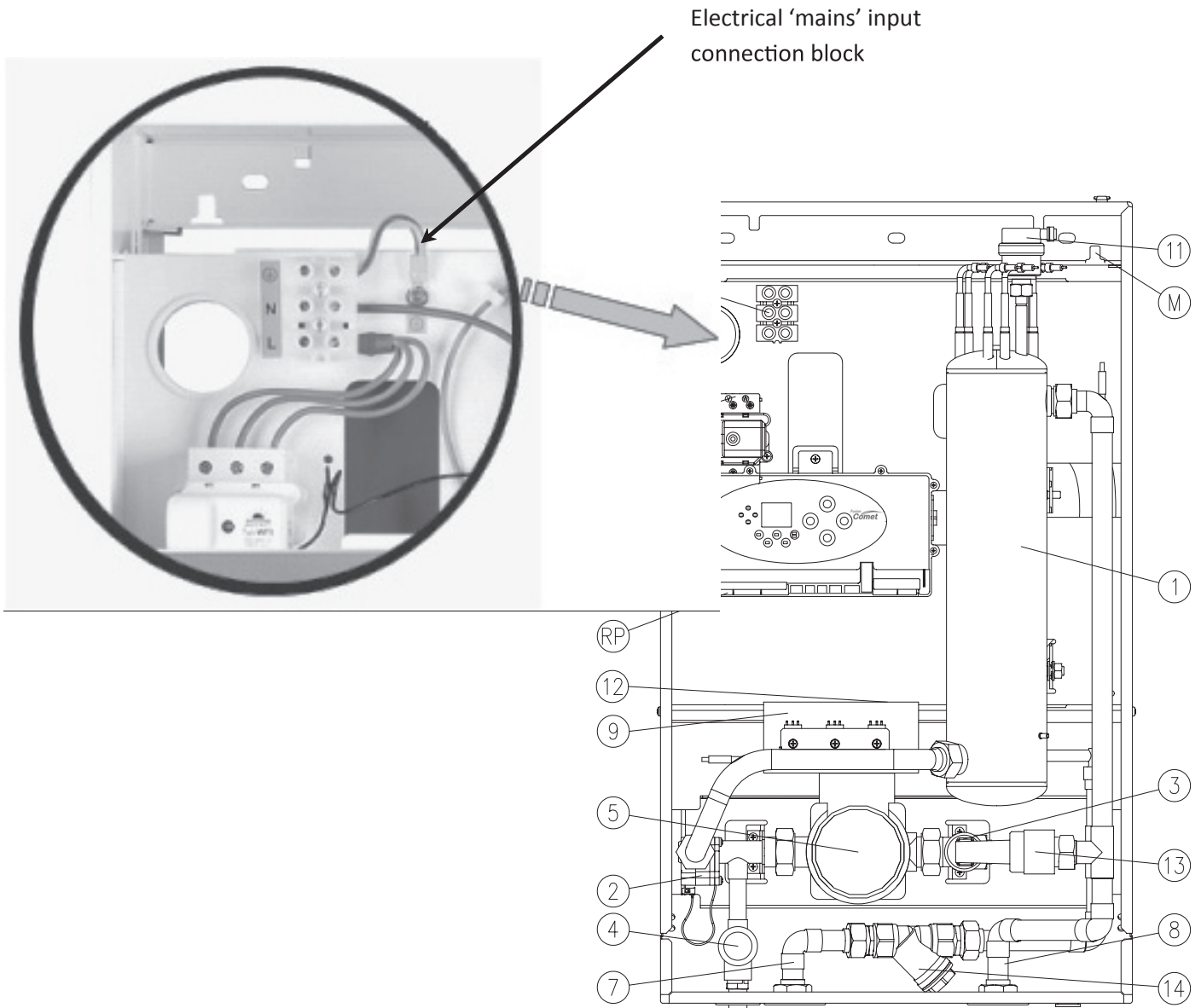

**Figure 1**

# INSTALLATION

## 12. System types

The Fusion Comet range of boilers can be used in various system designs. Please refer to The Electric Heating Company for more details on our Fusion Boiler for under floor heating. We are able to supply a heat pack that contains the relevant control valves, cylinder and room thermostats required to configure an „S” plan heating system. The heat pack has all the necessary components that you need to connect the systems controls and plumbing configurations for „S” Plan design.

We recommend the use of thermostatic radiator valves on all radiators except in the room that has the wall thermostat fitted. This radiator should be fitted with lock shield valves and left in the fully open position.

The boiler has an integral automatic bypass valve fitted which should be set to the relevant settings to allow the minimum flow rates to pass through the boiler (8 l/min) when all radiator thermostats and „zone valves are closed”.

Systems should be designed to meet the current building regulations in force at the current time.

## 13. Hanging the Boiler

1. Hang the boiler in a vertical position on the fixing points and screws provided, with the flow and return connections to the bottom of the boiler, maintaining the clearances as per Figure 12 of this manual.
2. Connect the boiler to a heating system that is equipped with isolation valves (see Figures 4 & 5).
3. Fill the heating system with treated water, which will substantially extend the life of the heating coils. See item 14 „System Protection” below.
4. Connect the boiler to the „mains” electrical system as per Figures 6, 8, 9 & 11 using conductors sizes as per as specified in the Technical Specification on page 17 of this document.
5. Connect the room thermostat / Programmer using the two control conductors marked RP as in Figure 7 & 10.
6. For all other electrical connections refer to the ELECTRICAL CONNECTIONS & CONTROL section of this manual.

## 14. System protection

Failure to protect the system will invalidate the manufacturer’s warranty.

After the system has been installed the cleansing and inhibiting procedure must be carried out as follows:

### Procedure:

1. Fill the system with cold mains water to the recommended pressure 1.5 bar and check for leaks, then drain the system thoroughly making sure all drain cocks are fully open and that the system is completely drained.
2. Add Fernox Heavy Duty restorer through the header tank or via filling loop at the recommended dose. One bottle must be used as a minimum per dwelling. If you are unsure of the correct dose rate, contact Fernox.
3. Re-fill the system and circulate the Heavy-Duty Restorer prior to the boiler being fired up, then commission the system in the normal way. The cleansing agent must be in the system for a minimum 1 hour with the system at normal operating temperature. A longer period of time would be more beneficial to the cleansing process especially if excess flux was used.

4. Drain and flush the system thoroughly to remove the cleaning agent and any debris or contaminant. This is a critical part of the cleaning process and must be carried out correctly. Use a rinse test meter (TDS), such as the Fernox CTM. The reading must be within 10% of the mains ppm value.
5. Then add the Fernox Protector (Copal MB1 or Super concentrate). This will protect against the formation of scale, corrosion and microbiological growths. It is crucial however, that for the protector to work correctly, the system must be properly cleansed and flushed.
6. The label included within the Fernox Protector carton should be completed and attached adjacent to the boiler.
7. We recommend inhibitor levels are checked on an annual basis (usually during the service) or sooner if the system content is lost. This should be carried out using a Fernox inhibitor Test Kit.
8. Fernox Technical Service Helpline on 0870 870 0362 for further assistance.

## 15. Start-up / Commissioning

1. Turn „mains” power on at main Isolating Switch.
2. Make sure that all external controls are not calling for heat at this stage.
3. Switch the boiler on by pressing the  $\text{\textcircled{P}}$  button).
4. Check to see that the correct installation water pressure is approx (1.0/1.5 bar) by pressing the right arrow key and correct as necessary. If the A indicator flickers the pressure is too low.
5. Vent the Pump in the following way:
  - Make sure the system is pressurized to the correct pressure.
  - Carefully undo the venting screw (see figure 2).
  - Vent until you see running water and all air from the boiler has been released.
  - You may need to repeat this process.
  - Check the system pressure and top up if required.
  - Re tighten the vent screw.
6. Turn on external controls to call for heat.
7. Set the temperature of the boiler to your desired temperature (normally 65°C).

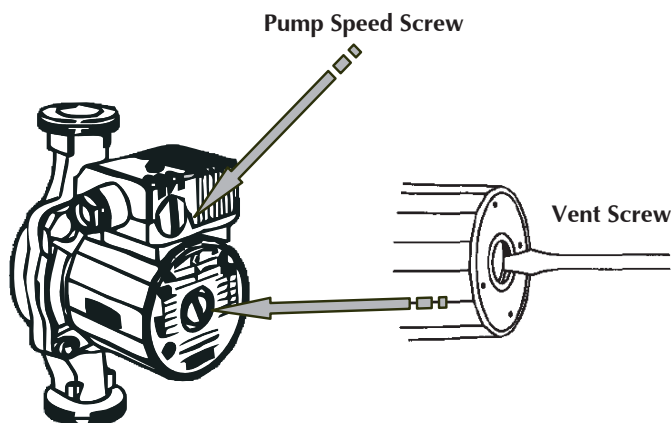

Figure 2

Figure 3



# INSTALLATION

## CENTRAL HEATING ONLY

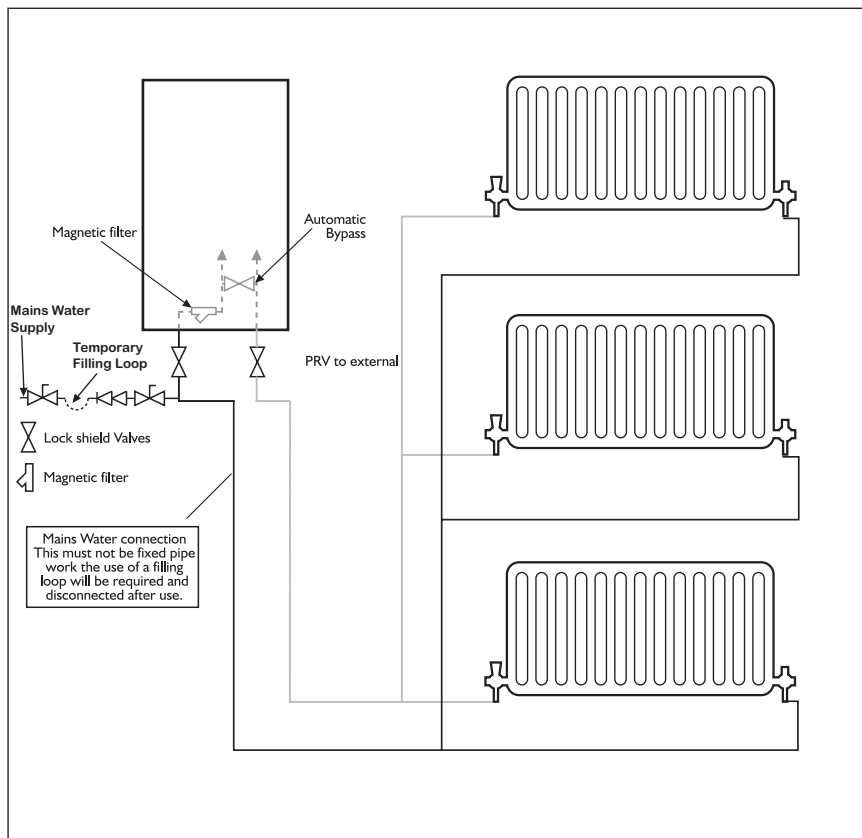

**Figure 4**

## CENTRAL HEATING & DOMESTIC HOT WATER

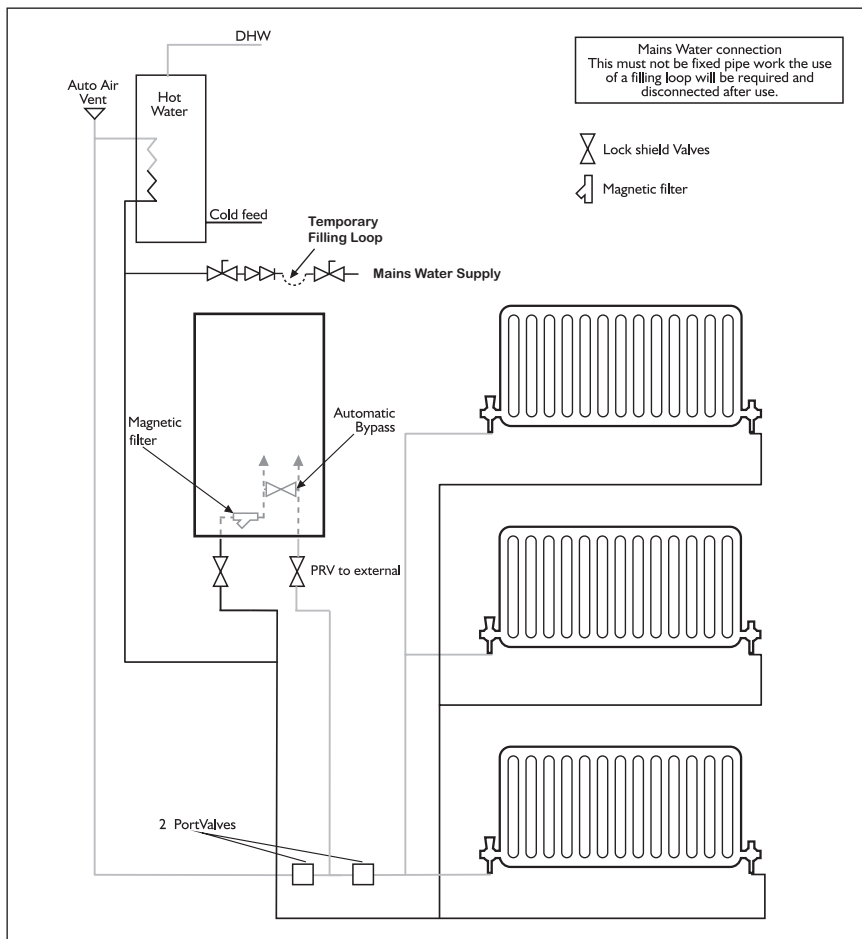

**Figure 5**

# ELECTRICAL CONNECTIONS AND CONTROLS

**ALL WIRING MUST BE CARRIED OUT IN ACCORDANCE WITH CURRENT IEE BS7671 WIRING REGULATIONS.**

**ALL ELECTRICAL CONNECTIONS MUST BE MADE BY A QUALIFIED TRADESPERSON.**

A load check should be carried out to ensure that there is a sufficient current and voltage for the intended boiler installation. Consideration should be taken into account with regard to the remainder of the properties load requirements.

All boilers must be protected at the meter position with a double pole fused switch with a minimum of 3mm contact separation. If the boiler is not fitted local to the meter position then an isolation switch must be fitted local to the boiler.

**THIS APPLIANCE MUST BE EARTHED.**

All pipe-work must be earthed in accordance with the IEE BS7671 Wiring Regulations.

After completion of all electrical works, an electrical safety check should be carried out i.e. short circuit, earth continuity, resistance to earth and polarity check, and all relevant Test Certificates completed.

Never open the front cover of the boiler until all power supplies to the boiler have been disconnected.

## ELECTRICAL CONNECTIONS

The boiler connections are clearly marked inside the boiler L ⊕ N (24hr LIVE).

The 24hr live is the permanent live connection to the boiler from the mains supply. External controls will require an independent fused spur supplied from the consumer unit., however this fused spur should be supplied by the same power source as the boiler itself.

## Boiler Protection

The recommended protection for hard wired boilers are as follows:

Model No	Boiler size	Protection (per phase)
FUSION 24 kW	24kW BOILER	40 AMP Protection
FUSION 14.4kW	14.4kW BOILER	80 AMP Protection
FUSION 12kW	12kW BOILER	63 AMP Protection
FUSION 9kW	9kW BOILER	45 AMP Protection
FUSION 6kW	6kW BOILER	32 AMP Protection

## External Controls

We recommend the use of the EHC Select 107XL Programmer and EHC TLX 4101 room stat for heating only installations.

For Heating and Hot water installations, we recommend the use of the EHC „Heat Pack” which includes the EHC Select 207XL programmer.

The EHC „Heat Pack” will incorporate all the relevant parts to comply with current building regulations i.e. Motorized valves to control the heating and hot water circuits and Room and cylinder thermostats to control the room and water temperatures. This will also provide boiler interlock. The use of TRV's alone will not provide boiler interlock.

We recommend the use of TRV's, however they must not be used in the room that has the room thermostat fitted.

**Note: This control method is recommended by TACMA (The Association of Control Manufactures) in order to comply with the current Building Regulations.**

## Electrical „mains” connection

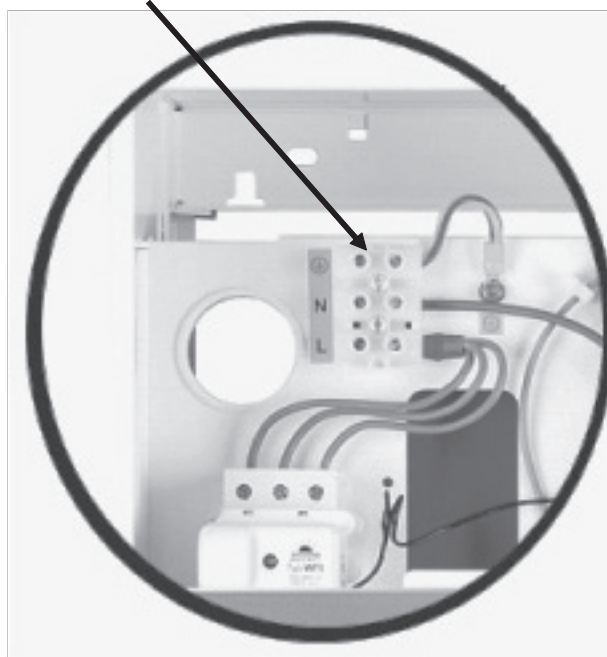

Figure 6



# ELECTRICAL CONNECTIONS AND CONTROLS

## Programmer/Stat Connections

The boiler PCB has a voltage free connection for the controls (RP) & (NA). Under no circumstances should 240V be connected to these controller block connections as this will damage the boiler's PCB and Void the Manufacturers warranty.

The stat / programmer connections are clearly marked within the boiler.

Only after all connections have been made and checked should the system be filled with water and set to the proper pressure 1.5 bar (Sealed systems).

Check the system for leaks. If water leaks into the boiler this may damage the boiler electrics and the manufacturers warranty will be invalid.

Under no circumstances should the boiler be switched on when the system is dry.

After the cleansing and protection of the system has been carried out, set the external controls to the customers selected times.

If an off-peak electric meter has been installed by an Electricity Company to supply OFF-peak rate electricity at selected times, the appropriate settings should be entered into to the system programmer to take advantage of the OFF-peak rate electricity.

The boiler has an inbuilt pressure sensor. If the boiler has been switched on with a low or no water content, the system will sense this and prevent the boiler from sending power to the main elements.

After the system has been filled with water and has had a cold flush the Fernox cleanser should be added, the system filled with water, purged of air and set to the correct pressure of 1.5 bar (sealed systems). At this point the main power may be switched on.

At this stage you may carry out the cleansing and protection of the system. Refer to the installation section of this manual. (See page 7).

„NA“ – Shower Sensor connection (optional)

„RP“ - Room Stat connection

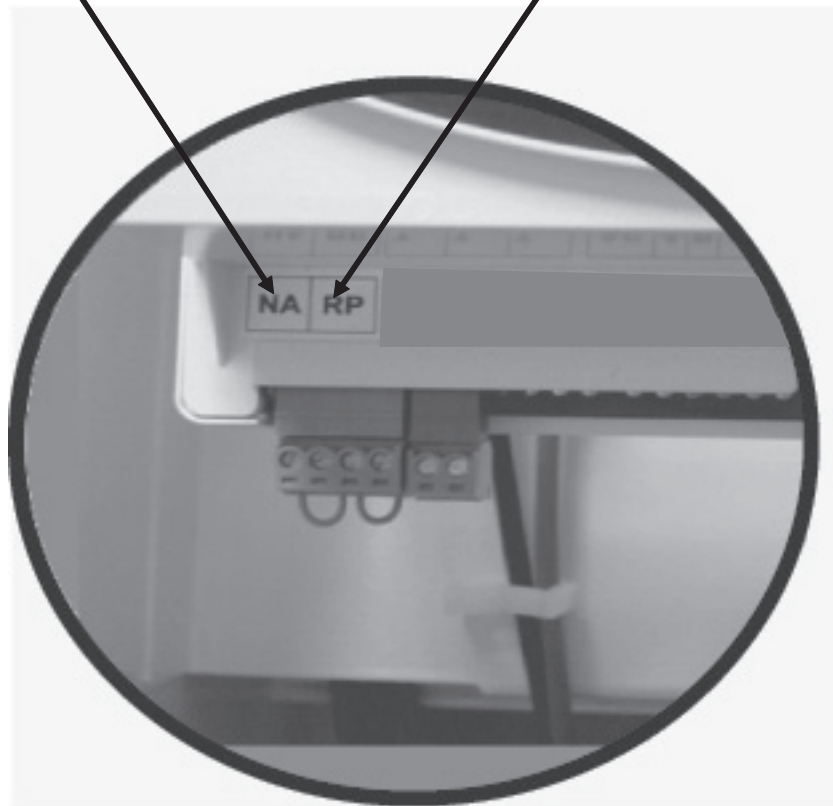
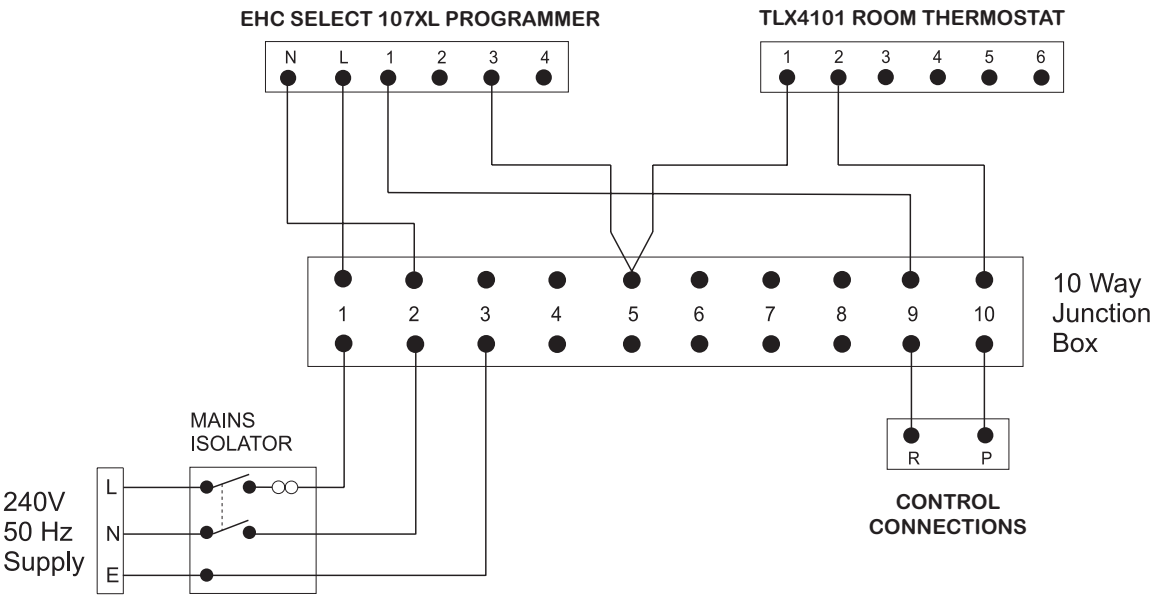

Figure 7

# EXTERNAL CONTROL WIRING

## Heating Only Wiring



**Figure 8**

## Heating & Hot Water Wiring: S Plan

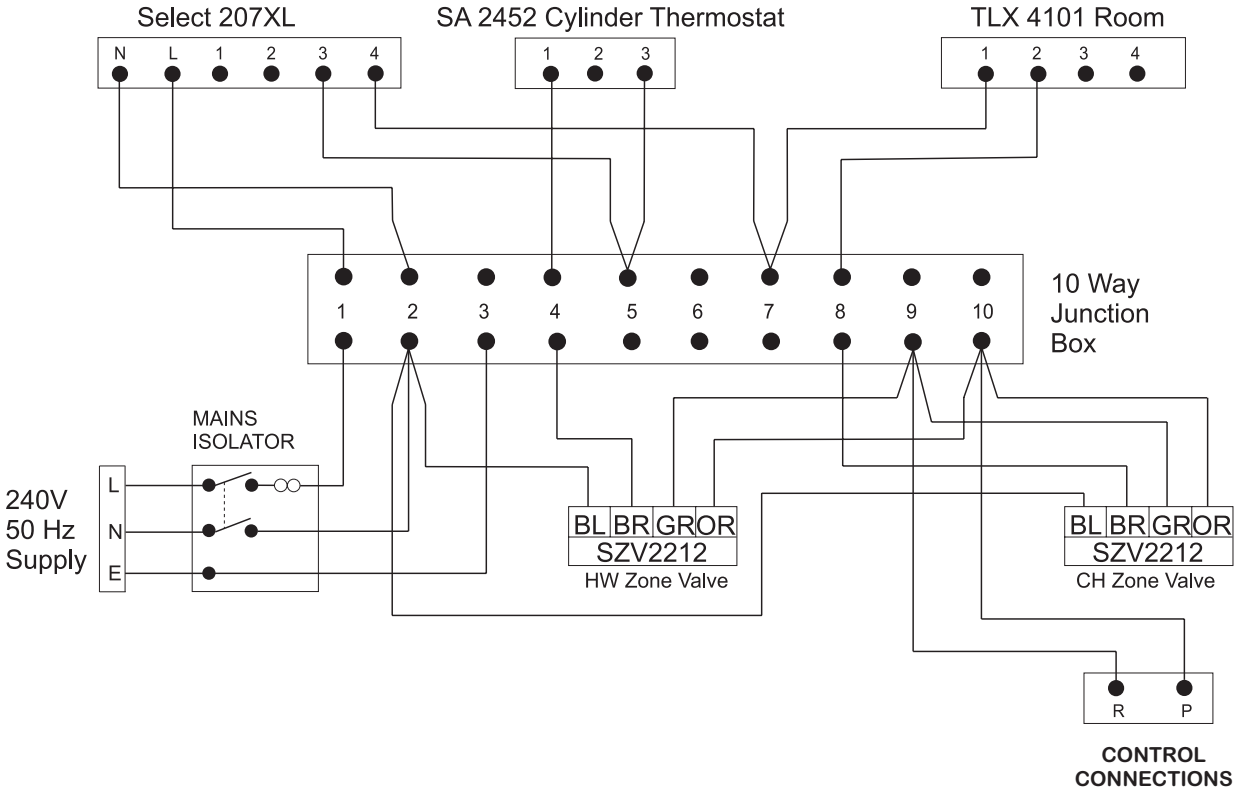

**NOTE!**  
 RP...are  
 Volt free  
 Contacts

**Figure 9**

# CONTROL PANEL CONNECTIONS

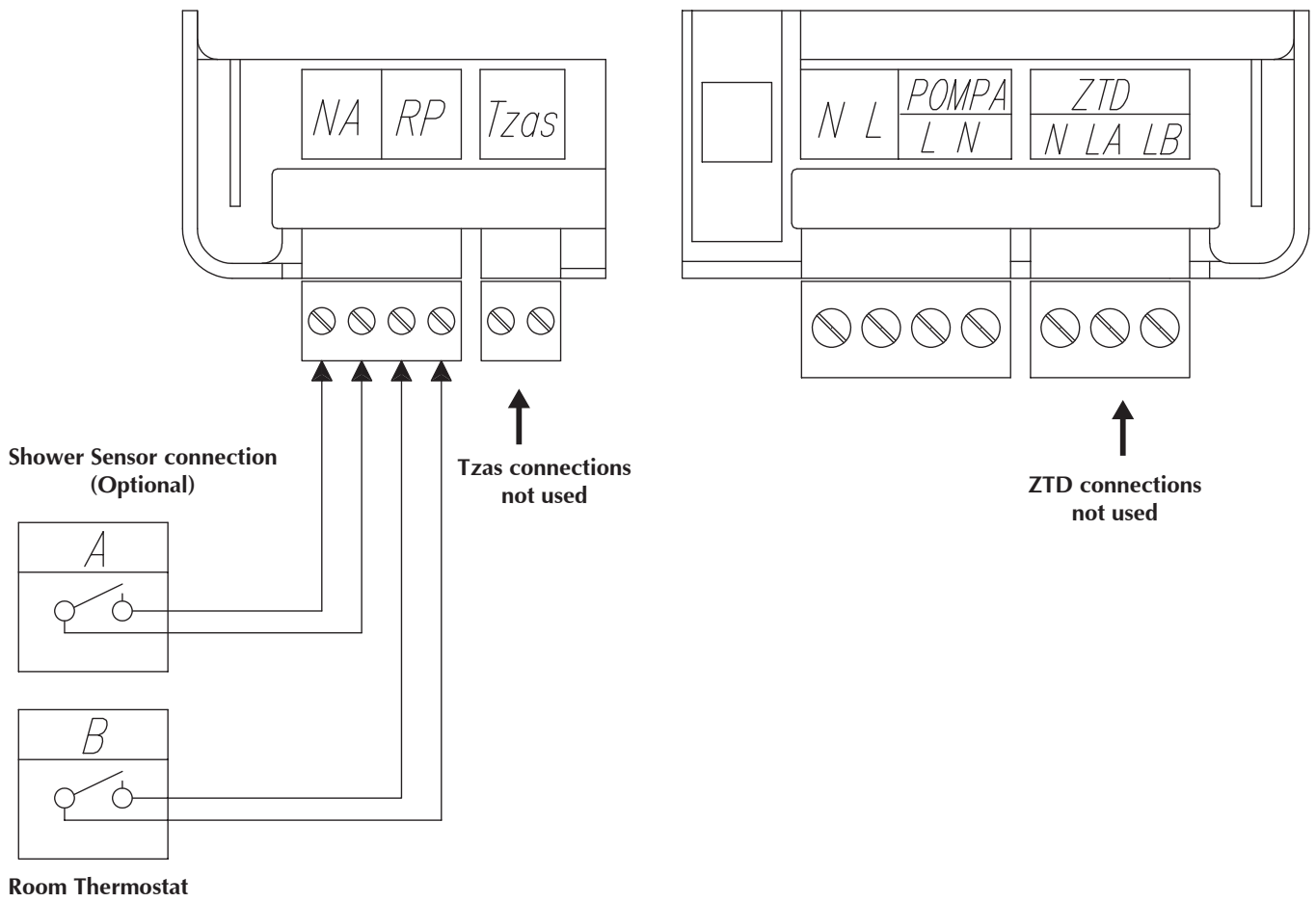

Figure 10

**SAFETY NOTE: „RP”, „Tzas” and „NA” are signal conductors only. DO NOT CONNECT ANY VOLTAGE to these as this will damage the boiler and invalidate the boilers warranty!**

## EXTERNAL BOILER WIRING

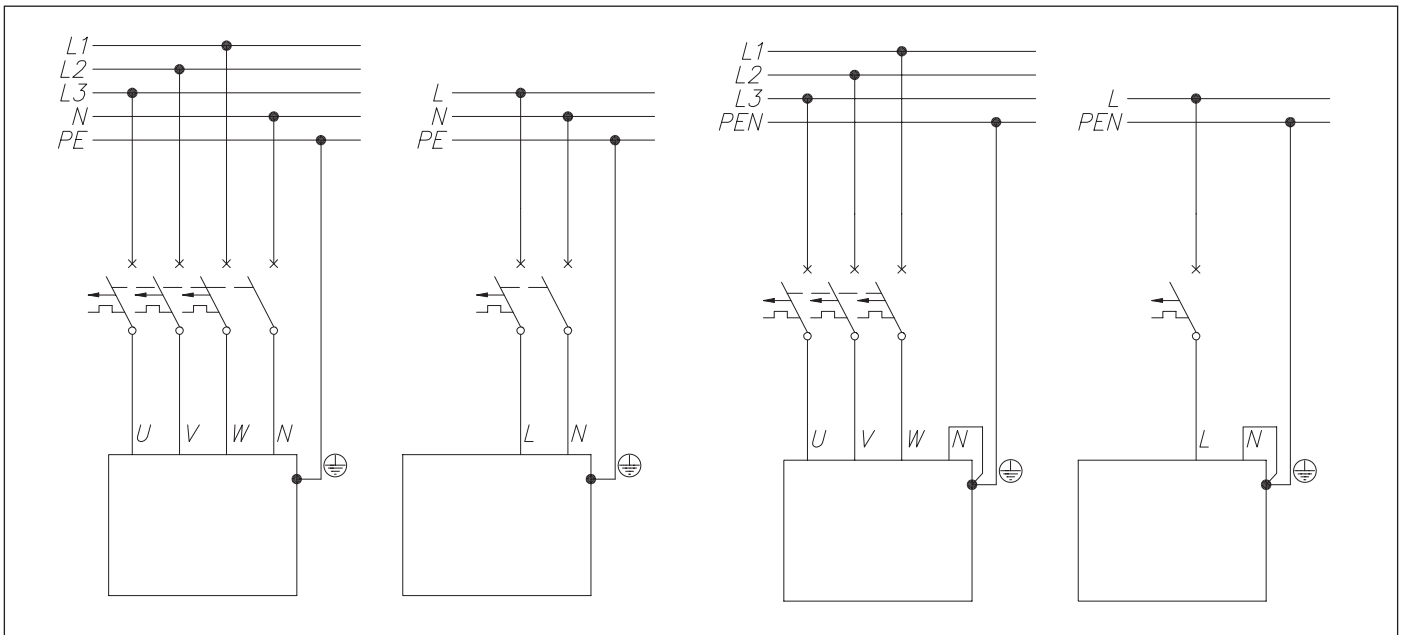

Figure 11

## BOILER DIMENSIONS

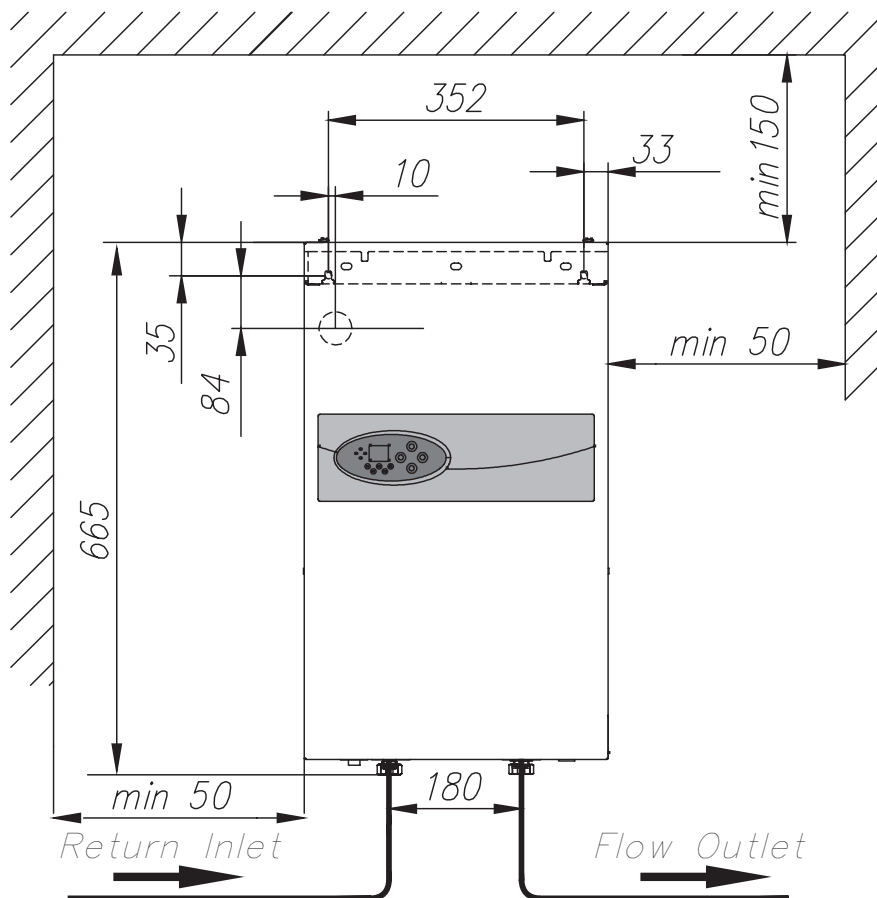

Figure 12

# USER INSTRUCTIONS

## CONTROL PANEL

### Control Panel Key

- A - Water pressure indicator (bar)
- B - Water flow rate indicator (l/min)
- C - kW indicator
- D - Water temperature indicator (°C)
- E - Digital display
- F - Summer Mode
- G - Call for Heat
- H - Pump operation indicator
- I - Return temperature flow indicator
- J - Flow temperature indicator
- K - Boiler heating indicator

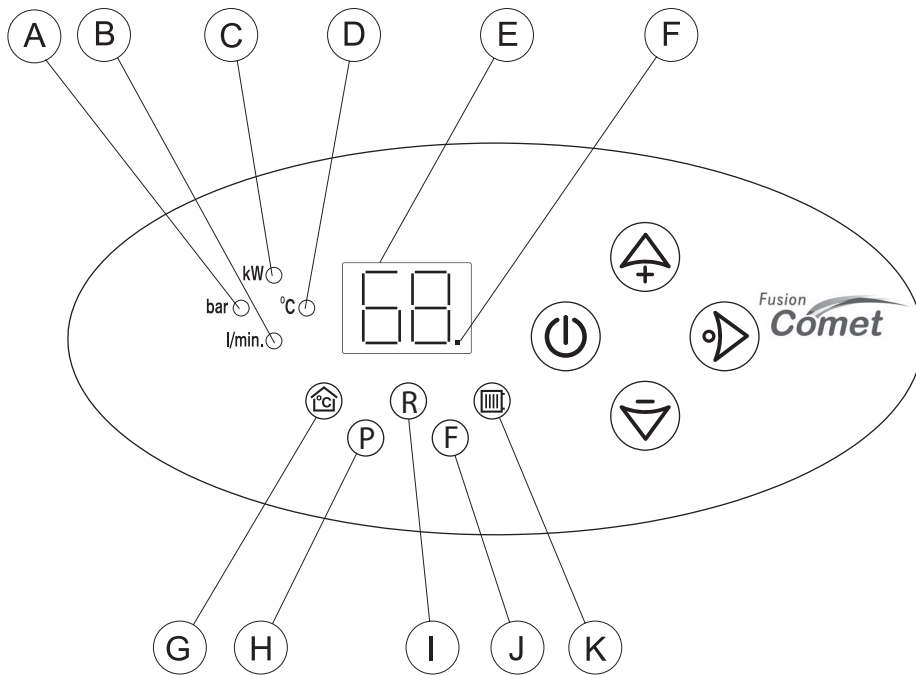





Figure 13

## INDICATORS

-  Heat Indicator.
  - „on” – calling for heat,
  - „off” – the required temperature has been reached – no call for heat is required,
  - Flickers – NA entry is open – (external boiler interrupt active).
-  Pump Indicator.
  - „on” – pump is active, proper flow rate of water has been reached,
  - Flickers – lack of flow or insufficient flow rate of water – heating elements are off.
-  Temperature Indicator.
  - Red light – Boiler is in heating mode.
  - Green light – Boiler temperature has been reached in radiators.

**A** Indicator flickers – water pressure is not sufficient (below 0.5 bar).

**F** When boiler is in Summer Mode (i.e. switched off) indicator will blink.

**I** Indicator flickers – relative temperature sensor failure.

**J** Indicator flickers – relative temperature sensor failure.

**EE** Messages on electronic display – data record error.









**Dashes (- -) on display** – parameter out of range or a temperature sensor failure.

# USER INSTRUCTIONS

## 1. General

Unlike other system boilers such as Gas, Oil and Propane the FUSION „Comet” range of electric boilers require no ignition or lighting sequence to be executed by the end user. All the end user is required to do is ensure that the system is filled with water and the room thermostat or programmer is calling for heat.

## 2. Boiler Operation

- 2.1 Switch the boiler on by pressing the  button. (Note: When switching the boiler off use the same  button by pressing and holding it in for 3 seconds.)
- 2.2 The recommended Water Pressure is approx 1.0/1.5 bar and this can be checked by pressing the  button until indicator A is illuminated. The water pressure can be adjusted by connecting the external filling loop and pressurizing to the desired pressure. Note: the filling loop must be disconnected after the system has been re-pressurized.
- 2.3 First set the required Boiler Temperature (we recommend a setting of 65°C) by pressing the  button until only indicators D and K are illuminated. Press the  button or the  button until the desired temperature setting is achieved.
- 2.4 Ensure the room thermostat is switched on and is calling for heat. If the boiler is not yet at the desired heat setting then indicators D, G, H, I, J & K will be illuminated with indicator K illuminated in red. Once the room has reached the required setting the K indicator should change from red to green. Refer to the Control Panel diagram above to learn how to adjust to the right temperature to make the boiler work comfortably and economically.
- 2.5 The boiler Flow Rate is set at 8 l/min during the installation of the boiler. To check this setting then press the  button a number of times until only indicator B is illuminated and then read the figure on the digital display. If the figure is well below the 8 l/min figure then call a Service Engineer for assistance.
- 2.6 To check the amount of kW energy being used by the boiler at any point in time then press the  button a number of times until only indicator C is illuminated and then read the figure on the digital display.
- 2.7 When indicator H is illuminated the pump is running.

## 3. Temperature Setting

We recommend the boiler temperature be set to 65°C. Raise or lower the temperature in your installation with the buttons on the right hand side of the control panel as per 2.3 in the previous section.

**ATTENTION: Should the temperature on the front panel be set too low the desired room temperature may not be achieved.'**

## 4. Summer Setting. („Stand by” Mode)

The customer has the option to switch the boiler onto „stand-by” mode during summer months and this can be carried out by pressing the  „button and holding this in for 3 seconds”. All indicators will go off except the F indicator which will intermittently illuminate.

## IMPORTANT - DO NOT SWITCH THE BOILER OFF AT THE MAINS SWITCH

In the „stand-by” mode all the boiler functions are switched off except the circulation pump. This is activated for 15 minutes each day which protects the boiler and the whole central heating system from being blocked and silted up. In this „stand by” mode the circulation pump will run each day at the same time. (e.g. If you switch the boiler to „stand by” at 6pm then the circulation pump will run every day at 6pm for 15 minutes) To return to a „Winter” mode setting then press and hold the  button for 3 seconds again.

## 5. Winter mode

In the Winter mode setting the digital display will be active and will show the temperature of the water at various points within the boiler. Those indicators which are illuminated will show the current status of the boiler. If the boiler is being called for heat by the thermostat then the G, H, I, J & K indicators will be illuminated. In the winter mode both the two port valves are active and they will direct heat as required.

**Note: When in diagnostic mode of the Display (i.e. using the arrow buttons), and there has been no activity (i.e. buttons pressed) for 60 seconds the Display will revert to its normal mode.**

NB: Voltage free control connections



## Boiler Dimensions

Width	418 mm
Height	710 mm
Depth	251.5 mm



## FAULT FINDING

Symptom	Reason	Procedure
The indicators and LCD display on the front panel are off	No power to the boiler	Check electricity mains power supply
	Main over heat stat cut-out	Check the temperature safety cut-out investigate cause - possibly fault / return sensors or power board
The „A” indicator flickering	Insufficient water pressure	Check water pressure in display panel and increase to 1.5 bar
	Pressure Sensor failure	Check water pressure in display panel and if display shows „- -” then replace Pressure Sensor
The „H” indicator flickering	Pump is blocked	Free Pump by setting the Pump on the highest gearing – See Figure 3 then unscrew the screw on the Pump housing – See Figure 2. Move Pump rotor manually.
	Water is not circulating through the Boiler	Vent the system: Radiators, Pump and Boiler
	Pump not running	Check power available at Pump head, if power available replace as necessary. If power not available check fuse on Controller Module and replace if necessary
	Flow sensor not operating	Check the flow sensor and replace as necessary
„G” indicator is flashing but boiler digital display operating	„NA” connection open circuit	Ensure „NA” connection is closed or if using external control (e.g. Shower Sensor) that this is working correctly
„G” indicator flashing	„NA” connection open circuit	Check „NA” connection - should be closed
„K” indicator flickers	Failure of inlet temp sensor	Replace inlet temp sensor
„L” indicator flickers	Failure of outlet temp sensor	Replace outlet temp sensor
„G” „H” & „K” Indicators lit but boiler not heating	No supply to heating coils from Power Board.	Check outputs „G1” „G2” & „G3” on Power Board if 230Volts not present to all replace Power Board
„G” „H” & „K” Indicators lit but boiler only partially heating	One or more heating coils have no voltage supply from Power Board	Check outputs „G1” „G2” & „G3” on Power Board if 230Volts not present to all replace Power Board

## TECHNICAL SPECIFICATIONS

Boiler range	Fusion Comet 6kW (EHCCOM6KW)	Fusion Comet 9kW (EHCCOM9KW)	Fusion Comet 12kW (EHCCOM12KW)	Fusion Comet 14.4kW (EHCCOM15KW)	Fusion Comet 24kW (EHCCOM24KW)
Pipe entry from boilers	Bottom	Bottom	Bottom	Bottom	Bottom
Central heating flow & return pipes	22 mm				
Min water pressure	1 bar				
Max water pressure	3 bar				
Expansion vessel	6 lt.				
	Maximum system water volume about 60 litres at initial system pressure 1,5 bar				
Vessel charge pressure	1,5 bar				
Safety Class	IP22				
Dry weight	25kg				
Electrical supply	230V 1ph 50Hz				415V 3ph 50Hz
Load/current	26,0 Amp.	39,1 Amp.	52,2 Amp.	62,6 Amp.	3 x 34,8 Amp.
Recommended diameter of mains cable	10mm		16mm		10mm
Heating output	20484Btu	30726 Btu	40968 Btu	49161 Btu	81936 Btu
Temp setting (factory set)	85°C				
Min temp setting	20 - 40°C				
Overheat Protection	100°C				
Pump included	Yes				
Recommended Pump settings	Set to max				
Protection	32 Amp.	45 Amp.	63 Amp.	80 Amp.	3 x 40 Amp.
The maximum allowed network impedance	0,39 Ω	0,32 Ω	0,24 Ω	0,22 Ω	



**Electric Heating Company Ltd**

Unit 40, Block 5  
Third Road  
Blantyre Industrial Estate  
Blantyre  
Glasgow

G72 0UP

Tel: 01698 820533 Fax: 01698 825697

[www.electric-heatingcompany.co.uk](http://www.electric-heatingcompany.co.uk)