



USER MANUAL FOR YOUR

HRCI 2570.1 Built-in combi fridge/freezer

NOTE: This User Instruction Manual contains important information, including safety & installation points, which will enable you to get the most out of your appliance. Please keep it in a safe place so that it is easily available for future reference, for you or any person not familiar with the operation of the appliance.

Contents

Environmental note	3
Important safety information	4 – 5
Specifications of your combi fridge freezer	6 -9
Product and aperture dimensions	6
Product specifications	6
Description of your appliance	8
Description of the product features	8
Using your combi fridge freezer	10-13
Before switching on	10
During first use	10
Turning on the appliance	11
Setting the fridge thermostat	11
Arranging and storing food in the fridge section	12
The  freezer compartment	13-16
Freezing fresh food	14
Tips on freezing	14
Making ice cubes	15
Normal operating noises	15
Saving energy when using your fridge-freezer	16-17
Cleaning and maintenance	17-20
Defrosting the refrigerator compartment	18
Defrosting the  freezer compartment	19
Replacing the light bulb	20
Installation	20-29
Electrical connection	20
Positioning	21
Reversing the doors of your appliance	22
Aperture dimensions and ventilation requirements	24
Installing your fridge freezer	26
Door slider fittings	28
Troubleshooting	29-31
Technical data	32
Contact details	36

Environmental note

Note: Before discarding an old appliance, switch off and disconnect it from the power supply. Cut off and render any plug useless. Cut the cable off directly behind the appliance to prevent misuse. This should be undertaken by a competent person. Disable the door lock to make sure that children cannot get stuck inside the appliance.

This appliance is marked according to the European directive 2002/96/EC on Waste electrical and Electronic Equipment (WEEE). By ensuring this product is disposed of correctly, you will help prevent potential negative consequences for the environment and human health, which could otherwise be caused by inappropriate waste handling of this product.

The symbol  on the product, or on the documents accompanying the product, indicates that this appliance may not be treated as household waste. Instead it shall be handed over to the applicable collection point for the recycling of electrical and electronic equipment.

Disposal must be carried out in accordance with local environmental regulations for waste disposal.

For more detailed information about treatment, recovery and recycling of this product, please contact your local city office, your household waste disposal service or the shop where you purchased the product.



Important safety information



Your safety is of the utmost importance to us. Please make sure that you read this instruction booklet **before** attempting to install or use the appliance. If you are unsure of any of the information contained in this booklet, please contact the Advice Line.

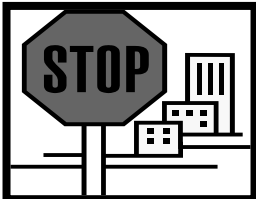

IMPORTANT: Any installation work must be carried out by a qualified electrician or competent person.

Use of the appliance

- Your appliance is only designed to be used in the home. It is suitable for storing food that needs to be chilled and refrigerated. If it is used for any other purpose or it is not used correctly, then the manufacturer will accept no liability for any damage that may be caused.
- Altering the specification of the appliance must not be attempted for reasons of safety.



Before using your appliance

- Check the appliance for any signs of transport damage. If you notice any damage, then you should not connect your appliance to your mains supply and should contact your retailer.

Refrigerant

- Your appliance contains R600a refrigerant, which is a natural gas that does not contain CFCs that can damage the environment. However it is a flammable substance, therefore care should be taken:
 - During the transportation and installation of the appliance, make sure that the refrigeration pipe work does not get damaged.
 - If it does become damaged then sources of ignition and open flames should be avoided. Also the room that the appliance is situated in should be thoroughly ventilated.

- Do not place any objects on top of the appliance, as this may damage the table top.



Child safety

- Packaging material should be kept away from children.
- Children should not be allowed to touch the controls or play with the appliance.



General safety

- Do not pull on the power supply cable to remove the plug from your mains supply socket.
- Do not pull out or insert the plug with wet hands.
- Do not attempt to use your appliance outdoors or any place where it is likely to come into contact with the elements.
- Before cleaning the appliance or performing maintenance work, ensure that the appliance has been disconnected from your mains supply.
- Never allow the back coils of the appliance to come into contact with the wall surface.
- Always ensure that the location where you are installing your appliance is free of stored items such as papers and other flammable materials.
- Never block the ventilation openings of the appliance, either on the inside or its exterior.
- It is vital to keep your appliance well ventilated, so that there is proper air flow between the bottom of the unit and the plinth/kick plate which it is sitting on.
- Do not place electrical devices inside of the appliance, such as mixers and electric ice cream makers.

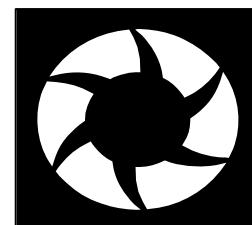
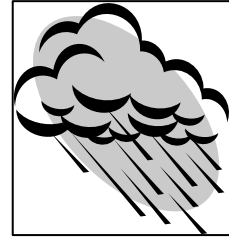

Service

You should not attempt to repair the appliance yourself, as this could cause injury or a more serious malfunction. If you require a service call then please contact the Advice Line.

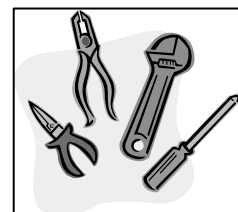

Specifications of your combi fridge freezer

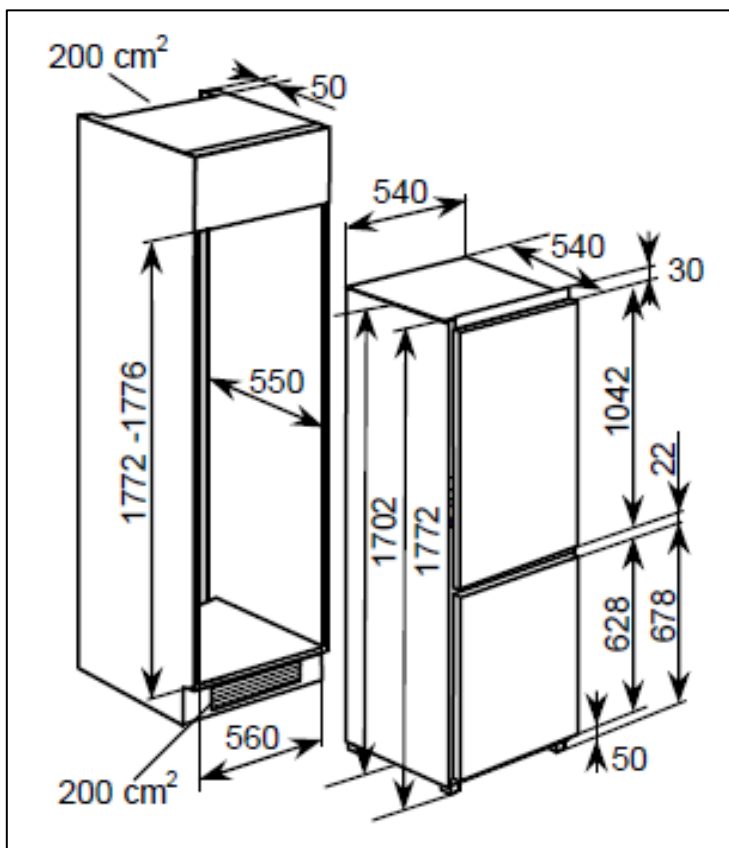

Product dimensions

Height: 1772 mm
Width: 540 mm
Depth: 540 mm

Aperture dimensions

Height: 1772-1776 mm
Width: 560 mm
Depth: 550 mm

Product specifications

- Total gross / net capacity: 259 / 250 litres
- Gross capacity fridge / freezer: 190 / 69 litres
- Net capacity fridge / freezer: 188 / 62 litres
- Freezing capacity: 3 kg / 24 hours
- Noise level: 42 dB
- Automatic fridge defrost
- Adjustable thermostat
- 3 x Adjustable safety glass shelves
- 1 x Salad crisper shelf
- 2 x Salad crispers
- 1 x Bottle rack
- 1 x Egg rack
- 3 x General door shelves
- **** freezer compartment
- 3 x Transparent freezer drawers
- Ice-cube tray
- Reversible doors
- Slider fittings

Energy efficiency class

Energy class: A+

IMPORTANT: When you install your appliance it is important to bear in mind its climatic rating.

In order to find out the climatic rating of your appliance, you should check the rating plate. The rating plate is located on the front left edge of the inside of the fridge section. You will need to open the door of your appliance to be able to find it. The rating plate will indicate the ambient temperature range that your appliance will function correctly within.

Description of the appliance

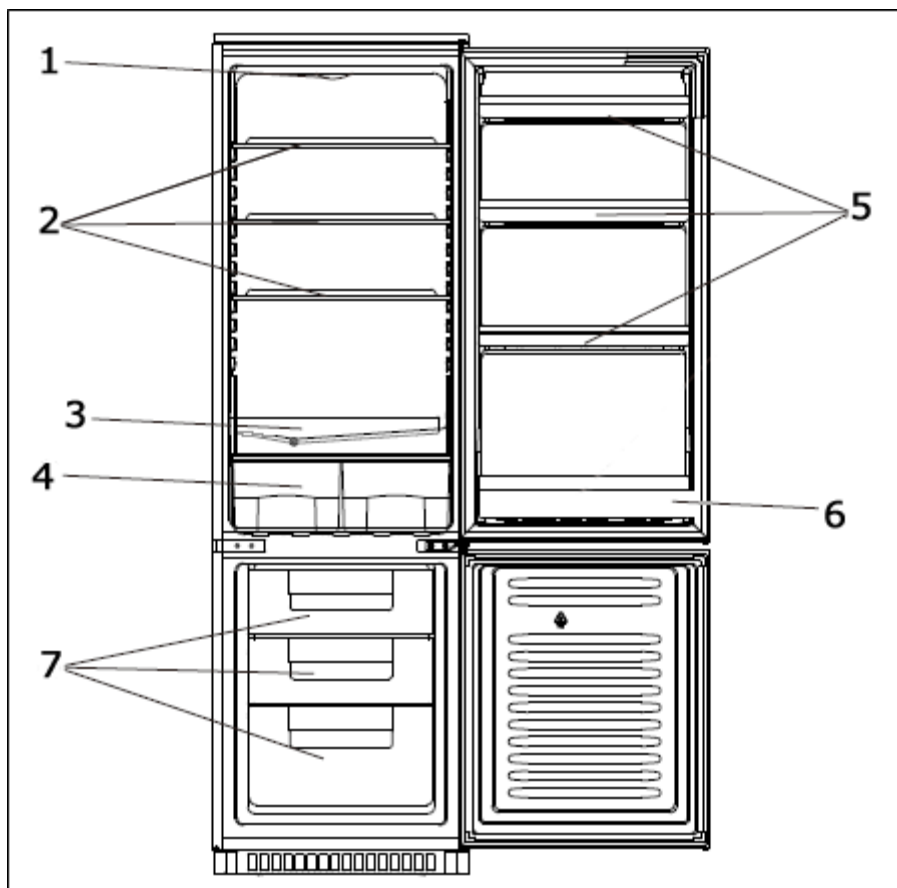

1. Internal light / thermostat control dial
2. Adjustable safety glass shelves
3. Salad crisper shelf
4. Salad crispers
5. General door racks
6. Bottle rack
7. Transparent freezer drawers

Description of the product features

1) Adjustable shelves

- The shelves may be placed in any of the guide slots within the interior of the appliance. They are protected from sliding out.
- To remove a shelf: Take off all of the items that are stored on the shelf that you want to remove. Then lift the front of the shelf and carefully pull it out of the grooves.

2) Defrost water outlet

- The interior of the refrigerator is cooled by the cooling plate that is on the rear wall. Beneath this there is a channel and an outlet for the defrost water.

- It is important that this channel never becomes clogged (see “Defrosting the refrigerator compartment” on pages 18 - 19 for a detailed explanation of how to keep the channel clear).

3) Crisper drawers and cover

- The crisper drawers are in the bottom of your refrigerator and there is a cover that goes over them.
- The cover helps to prevent fruit and vegetables from drying out prematurely.

4) Upper door shelves

- The door liner holds various shelves, which are suitable for storing eggs, cheese, butter and yogurt. As well as smaller packages, tubes, cans etc.

5) Bottle shelf

- The lower shelf should be used for storing reasonably sized bottles.
- ***IMPORTANT: IT IS IMPORTANT THAT NONE OF THE SHELVES THAT SIT IN THE DOOR ARE OVERLOADED, AS THIS WILL DRASTICALLY REDUCE THEIR WORKING LIFE.***

6) Freezer compartment

- A ❄️ freezer section, with a net capacity of 62 litres.

Using your combi fridge freezer

Before switching on

- Make sure that it has been installed by a suitably qualified person, as per the information contained in the manufacturer's installation instructions.
- After delivery, wait for eight hours before connecting the appliance to your mains supply. This will allow any refrigerant gasses that may have been disturbed during the transportation process to settle.
- The outside of the appliance and the removable accessories contained within it, should be cleaned with a solution of liquid detergent and water.
- The interior of the appliance should be cleaned with a solution of sodium bicarbonate dissolved in lukewarm water. The interior and accessories should be thoroughly dried, after the cleaning process has been completed.
- There can be an odour when you first switch on the appliance. It will lessen as the appliance starts to cool.

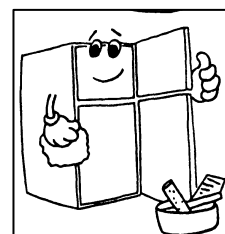

During first use

- When you first switch on the appliance, the compressor will run continuously for approximately 24 hours or until the fridge freezer reaches a cool enough temperature.
- During this period of time, you should try not to open the door frequently or place a large amount of food within the appliance.
- If the unit is switched off or unplugged, you must allow at least 5 minutes before restarting the appliance on the thermostat or connecting it to your mains supply.

Turning on the appliance and setting the thermostat in the fridge section



You switch on your appliance by connecting it to your mains supply and setting the thermostat.

- The thermostat automatically regulates the temperature inside the refrigerator, depending on what number you have turned the thermostat control knob to.
- Position <0> means that the appliance will not cool. However the light will still function.
- Position <1> will give you a higher temperature inside the fridge freezer
- Position <7> will give you a lower temperature inside the fridge freezer.
- Ideally the thermostat should be set to position <3> or <4>.
- Your refrigerator can maintain a temperature of between 4 – 6 degrees centigrade.
- The freezer section can cool down to -18 degrees centigrade and lower.
- ***IMPORTANT:*** *The ambient temperature of the room, the temperature of food and the amount of food that has been placed in the appliance and how often the door is opened, will all affect the temperature being maintained by the appliance.*
- On the maximum setting (position <7>), your fridge freezer will work harder to maintain a lower temperature and will increase the energy usage. There is no need to run your appliance on this setting for prolonged periods and you should return the thermostat knob to position <3> or <4>.

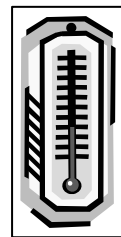

Arranging and storing food in the fridge section

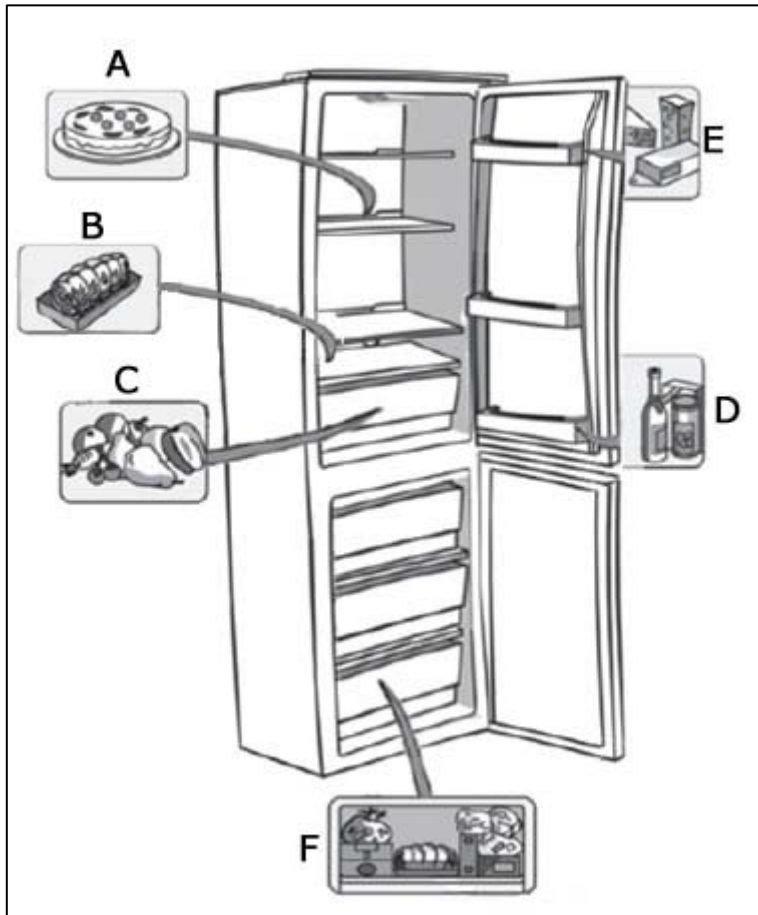

- A)** Cooked food
- B)** Cooked meat
- C)** Fruit and vegetables
- D)** Bottles / cartons
- E)** Butter / cheese / yoghurt
- F)** Frozen foods

- Warm food or evaporating liquids should not be stored in your refrigerator, as this will increase the humidity inside of the appliance.
- All foods should be wrapped or covered, this is particularly important if the food has a strong flavour. You should use polythene bags or sheets, aluminium foil, wax paper. Liquids should be stored in covered containers or bottles.
- To maximise the space inside of the fridge section, any excessive packaging on the food should be removed.
- Quickly perishable food should be stored at the back of the refrigerator, which is the coldest part of the appliance.
- No food items should be allowed to come into contact with the back wall of the refrigerator.
- Make sure that you arrange food in such a way that the door can close completely. Particular attention should be given to bottles that may protrude when placed on shelves inside the main section of the refrigerator.

- Some organic solutions, such as the oils in lemon/orange peel and acid in butter, can cause damage to the plastic parts contained inside of the refrigerator.
- Do not open the refrigerator door too often or leave the door open for long periods of time, as this will increase the temperature inside of the appliance and will increase the energy usage.
- **Meat** should be wrapped in polythene bags and then placed in the meat drawer.
(Meat should only be stored in this manner for one or two days at the most).
- **Cold dishes/cooked food** should be covered and can be placed on any shelf.
- **Fruit and vegetables** should be cleaned thoroughly and placed in the salad drawer.
- **Cheese and butter** should be placed in airtight containers, or they can be wrapped in aluminium foil or polythene bags. They should be stored in the general door racks. As much air as possible should be removed from the bags.
- **Milk bottles** should have a cap on them and be stored on the bottle shelf that sits in the door.
- **Garlic, potatoes, onions and bananas should only be stored in a refrigerator IF they are stored in airtight containers.**

The freezer compartment

The freezer compartment is suitable for storing and freezing food.

- The freezer compartment temperature must have already reached -18 degrees centigrade (or lower) before you attempt to store food that is already frozen or freezing fresh food.
- The freezer compartment is only able to freeze a certain quantity of food at one time. You should not attempt to freeze more than 3 kilograms of fresh food within a 24 hour period.
- Preferably the top drawer should be used when freezing fresh food. Once the food is frozen, you can then transfer the food to the lower drawers.

- Warm food should be allowed to cool down before you attempt to freeze it. If you place warm food in the freezer compartment, then the increased humidity will cause quicker ice formation and increase the amount of power that the appliance uses.
- The guidance of the food manufacturer should be followed, in regard to the maximum storage time.
- Thawed foods must not be frozen for a second time.

Freezing fresh food

- Fresh food should be packed into airtight containers or packaging. This will help to make sure that the food doesn't dry out or lose its flavour. It will also ensure that flavour does not transfer from other foods.



- The food should be placed in the freezer drawers. Do not allow fresh food to touch items that are already frozen.

- After 24 hours you should check that the fresh food is satisfactorily frozen.

Tips on freezing

- Freezer bags, polythene wraps, aluminium foil (extra thick) and special cans for frozen foods are suitable packaging for storing frozen goods in.

- Tape, rubber bands or plastic clips are suitable for sealing bags and wrappings.

- Before sealing a suitable bag, you should compress the air out of it, as this will help the food to freeze more easily.

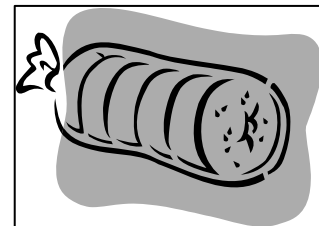













- Flat packages freeze more easily.



- If you are freezing liquid, then do not fill the container to the brim. Liquids will expand when being frozen.

- ***Do not place bottles (glass or tin) containing liquids (especially sparkling liquids) into the freezer as they could cause the bottle to burst during freezing.***
- For a guide to the recommended freezer storage time for different foods please refer to the chart below.

2 - 3 MONTHS			
4 - 6 MONTHS			
6 - 8 MONTHS			
10 - 12 MONTHS			

Making ice cubes

- Fill the ice cube tray with water and place it in the upper freezer drawers.
- After the water is completely frozen and turned to ice, you can twist the ice cube tray (as shown in the drawing below) to dispense the ice.

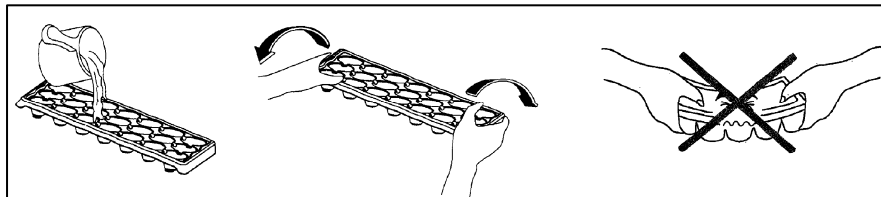

Normal operating noises

Ice cracking noise

- Can be heard during the automatic defrosting process.
- Can be caused by expansion and contraction within the fridge freezer.

Short cracking noise

- Can be heard when the thermostat turns the compressor on and off.

Compressor noise

- There will be an operating noise when the compressor is running.
- After installation, the compressor may be noisier for a short period of time.

Bubbling and burbling sound

- This noise is emitted as the coolant flows through the pipework within the fridge freezer.

Water flowing sound

- This is caused by water flowing into the evaporating tray during the defrosting process and can be heard whilst the fridge is defrosting.

Saving energy when using your fridge-freezer

There are some simple things you can do to save energy when installing or using your fridge-freezer:

Installing:

- Install the appliance in a cool position. If it is placed in direct sunlight or next to an oven or other heat source, the energy consumption can increase substantially.
- Ensure the appliance is installed with the correct ventilation requirements. Restricting ventilation can increase the energy consumption by 15%.

Cleaning and Maintenance:

- Occasionally clean the condenser coils (if present) at the back of the appliance to maintain a high performance level.
- Clean the door gasket with warm water or a neutral detergent that leaves no residue. A tight-sealing door gasket is critical to the efficiency of your appliance.

Usage:

- Do not open the door repeatedly or more frequently than you have to.
- Do not set the thermostat too low. A change of just one degree can effect the energy consumption by 5%. Use a thermometer to check the temperature.

- The freezer compartment should operate at around -18 degrees Celsius. The refrigerator compartment should operate at around 3 to 4 degrees Celsius.
- Allow food to sufficiently cool before putting it in the appliance (but do not let it sit at room temperature for too long).
- In the freezer compartment, food packages should be scattered and never grouped or stacked together until they are completely frozen.
- If you are going away for a long period of time, turn off the appliance, empty and clean it and leave the door ajar.
- If you have a second appliance that is not used, make sure that it is stored with the power off and the door left ajar until it is actually required.

Disposing:

- If you're going to throw out your old fridge, see if there's a chlorofluorocarbons (CFCs) recycler in your area. The government department which looks after the environment in your area may be able to help you.

Cleaning and maintenance

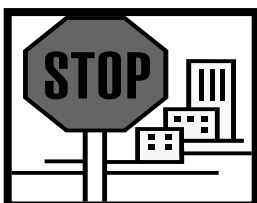

WARNING: PLEASE ENSURE THAT YOUR APPLIANCE IS DISCONNECTED FROM YOUR MAINS SUPPLY BEFORE ATTEMPTING TO CLEAN IT.

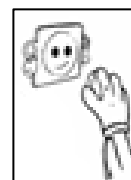

- Do not clean the appliance by pouring water onto it or spraying water over it.



- The refrigerator and freezer compartment should be cleaned periodically, using a solution of bicarbonate of soda and lukewarm water.

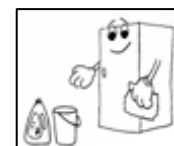

- Clean the accessories separately with soap and water. Do not clean them in a dishwasher.

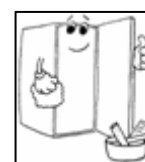

- Do not use abrasive products, detergents or soaps.



- After washing the appliance, wipe over the area that you have cleaned with a damp cloth and then dry it thoroughly.
- You should periodically clean the air vents and condenser at the rear of the appliance with a vacuum cleaner or brush.

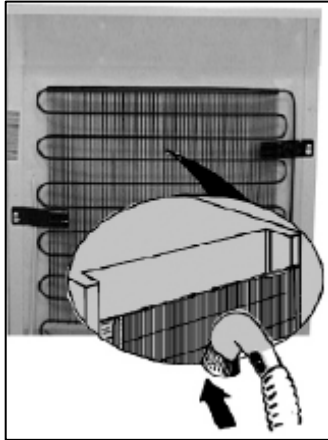

- When cleaning is complete, dry your hands and then reconnect the plug to your mains supply.

Defrosting the refrigerator compartment

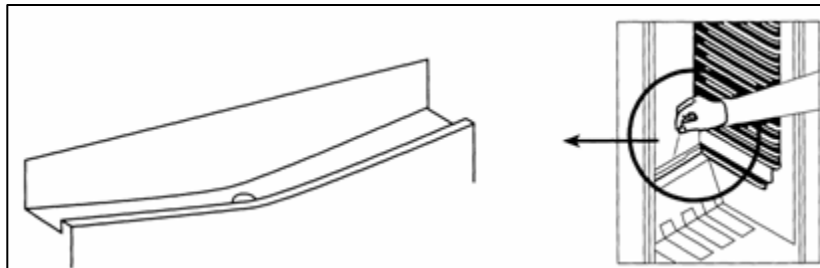

- Defrosting occurs automatically in the refrigerator section during operation. The defrost water is collected by the evaporating tray and evaporates automatically.
- The evaporating tray and defrost water drain hole should be cleaned periodically with the defrost drain plug. This will prevent water from collecting in the bottom of the refrigerator, instead of flowing down the defrost drainage channel and drain hole.
- You can also pour a small amount of water down the drain hole to clean inside of it.

- You should be careful to make sure that food packages do not touch the rear wall of the appliance, as this can interrupt the automatic defrosting process and deflect water into the base of your refrigerator.

Defrosting the freezer compartment

The frost in the freezer compartment should be removed periodically. You can use a plastic scraper to keep down the amount of frost that builds.

IMPORTANT: *The freezer compartment should be defrosted at least twice a year. The number of times that you need to defrost it, will depend on the setting of your thermostat and how much food you freeze and store in the compartment.*

- Whilst defrosting the appliance, the food should be removed from the compartment and wrapped in several layers of paper and stored in a cool place. The foods rise in temperature will shorten its storage life and therefore the food should be used within a relatively short period of time.
- ***DO NOT PLACE FOOD BACK IN THE FREEZER COMPARTMENT THAT HAS STARTED TO THAW.***
- Turn the freezer off and disconnect the appliance from your mains supply.
- Leave the door to the freezer compartment open. You can place a bowl of warm water inside the freezer compartment to speed up the defrost process.
- It is recommended to line the floor in front of the freezer with old towels to absorb the defrost water and prevent any damage to the floor surface or surrounding furniture.
- Once all the ice that has built up has melted, then the inside of the freezer compartment should be dried thoroughly. Failure to do this will result in immediate ice build when the appliance is turned back on.
- With dry hands, reconnect your appliance to your mains supply. Set the thermostat knob to position <7> for a 24 hour period, before returning the appliance to the usual setting of <3> or <4>.
- You should not attempt to freeze fresh food inside the freezer compartment until this 24 hour time period has elapsed.

- *Do not defrost the appliance with other electrical devices (e.g. hair dryer). Do not use sharp metal objects to remove the ice on the freezer, as this could cause damage to the refrigerant system.*

Replacing the light bulb

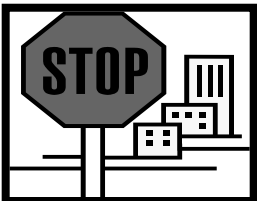

WARNING: PLEASE ENSURE THAT YOUR APPLIANCE IS DISCONNECTED FROM YOUR MAINS SUPPLY BEFORE ATTEMPTING TO REPLACE THE LIGHT BULB.

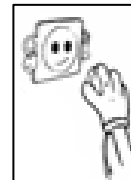

- Squeeze the tabs on the sides of the bulb cover to remove it.
- Remove the light bulb and replace with a bulb of the same type and wattage.
- Replace the bulb cover and wait for 5 minutes before plugging the appliance back into the mains.

Installation

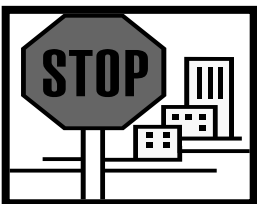

IMPORTANT: Before installation and usage, read all the instructions and make sure that the voltage (V) and the frequency (Hz) indicated on the rating plate are exactly the same as the voltage and frequency in your home. The rating plate can be found on the front left edge of the inside of the refrigerator.

The manufacturer declines all responsibility in the event of the installer failing to observe all the accident prevention regulations in force, which are necessary for normal use and the regular operation of the electric system.

Electrical connection



YOUR FRIDGE FREEZER IS INTENDED FOR FITTED AND PERMANENT INSTALLATION.

We recommend that the appliance is connected by a qualified electrician, who is a member of the N.I.C.E.I.C. and who will comply with the I.E.E. and local regulations.

- Your refrigerator comes supplied with a 13 amp plug fitted. If in future you need to change the fuse in this plug, then a 13 amp ASTA approved (BS 1362) fuse **must** be used.
- The wiring in the mains lead is coloured as follows:

Brown	Live
Blue	Neutral
Green and yellow	Earth

- As the colours of the wires in the appliance's mains lead may not correspond with the coloured markings identifying the terminals in your spur box, please proceed as follows:

The **brown wire** must be connected to the terminal marked "L" (live), or coloured **red**.

The **blue wire** must be connected to the terminal marked "N" (neutral), or coloured **black**.

The **green and yellow wire** must be connected to the terminal marked "E" (earth), or by the earth symbol, or coloured **green and yellow**.

- When the connection is completed, no stray strands or cut wire should be present. The cord clamp must be secured over the outer sheath.

Positioning

- It is advisable that your appliance is only installed in a location where the ambient temperature of the room, corresponds with the climate classification that is stated on the rating plate of your appliance. Your appliance may not function correctly if the ambient temperature falls outside of the following ranges.

<i>Climate classification</i>	<i>Appropriate ambient temperature</i>
SN	+10 to +32 degrees centigrade
N	+16 to +32 degrees centigrade

- Your appliance should not be located in direct sunlight or exposed to continuous heat or extremes of temperature (e.g. next to a radiator or boiler).
- The door should be able to open completely and freely
- The appliance should be situated so you can easily access the food that is stored in it.
- You should check whether there is an electrical socket available, which will be accessible after your appliance is installed.

Reversing the doors of your appliance

The doors of your fridge freezer can be set to open from the left or the right. If you want the doors to be hinged on the left hand side and opening from the right hand side, you will need to follow the door reversal process.

IMPORTANT: If required, the doors should be reversed **PRIOR** to installing the appliance into the housing unit.

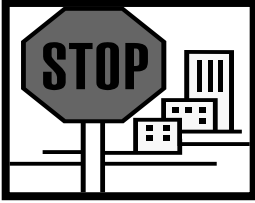

Caution! After unscrewing any of the fixing hinges, hold the door to prevent it from falling and causing damage.



Any parts that you remove from the appliance whilst reversing the door, should be retained for later use.

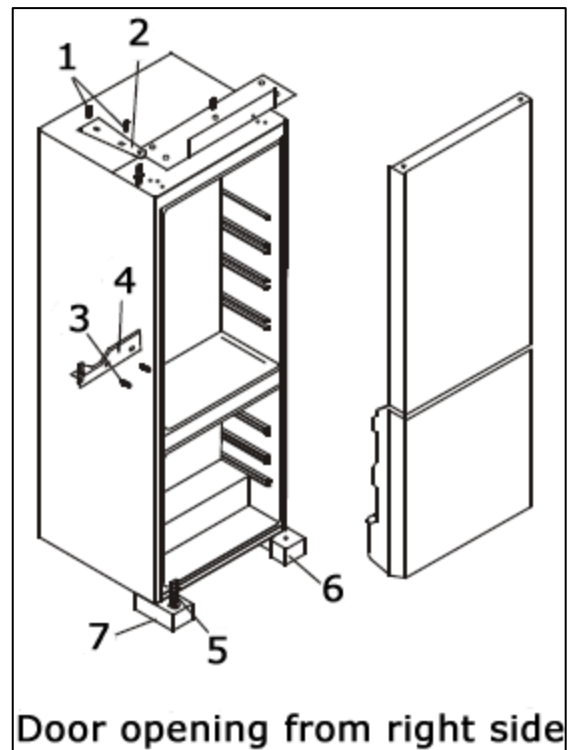
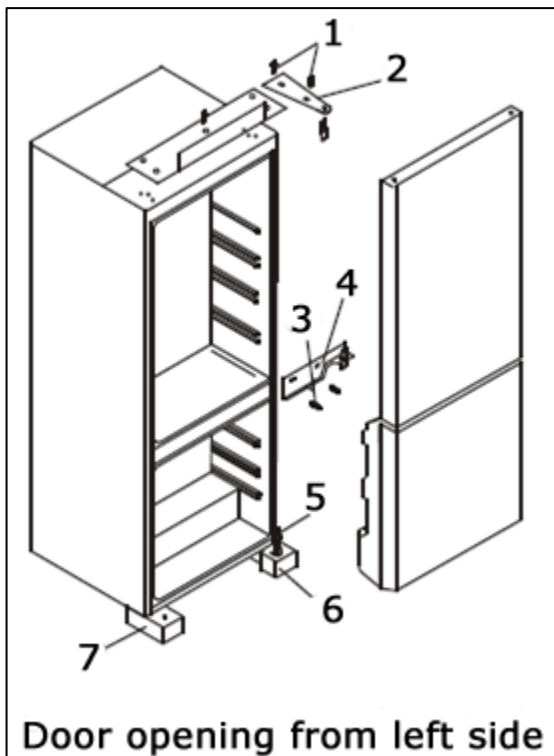

- Remove the two screws (1) holding the top hinge (2) to the right hand side of the frame. Remove the hinge (2).
- Lift the upper door off the middle hinge pin and place it on a cushioned surface to prevent scratching it.

- Remove the two screws **(3)** holding the middle hinge **(4)** in place. Remove the middle hinge **(4)**.
- Lift the lower door off the bottom hinge pin and place it on a cushioned surface to prevent scratching it.
- Remove the hinge pin **(5)** from the bottom right hinge **(6)** and move to the bottom left hinge **(7)**.
- Replace the lower door by locating it onto the bottom left hinge pin **(5)**.
- Reverse the direction of the middle hinge **(4)**.
- While holding the lower door in the closed position, reassemble the middle hinge **(4)** onto the middle left hand side using the two screws **(3)**. DO NOT tighten the screws **(3)** until the top of the lower door is level with the counter top.
- Replace the upper door by locating it onto the left middle hinge pin **(4)**.
- While holding the upper door in the closed position, reassemble the top hinge **(2)** on to the left hand side using the two screws **(1)**. DO NOT tighten the screws **(1)** until the top of the upper door is level with the counter top.

IMPORTANT: Check that both the upper and lower doors open and shut correctly after you have completed the door reversal process.



After the door has been reversed, you should check the door seal of the fridge and freezer door. Neither seal should be creased or crushed; otherwise there will be a gap between it and the inside of the door.

- The seal must adhere properly all the way around the door.
- If either seal is not adhering to the cabinet properly, then you should either: -
 1. Use a warm damp cloth and manipulate the seal until it does adhere to the cabinet properly, all the way around the door.

or

2. Use a hair dryer on its lowest heat setting and lightly heat the areas of the door seal that are not adhering correctly. The heat will make the seal more pliable and this will allow you to manipulate the seal into the correct position.

IMPORTANT: DO NOT HEAT THE DOOR SEAL ON ANYTHING BUT THE LOWEST HEAT SETTING, OR HEAT THE SEAL FOR A LONG PERIOD OF TIME. OTHERWISE DAMAGE MAY BE CAUSED TO THE DOOR SEAL, WHICH WOULD NOT BE RECTIFIED UNDER THE GUARANTEE FREE OF CHARGE.

IMPORTANT: WHEN YOU HAVE REVERSED THE DOORS OF THE APPLIANCE; AS YOU HAVE PLACED THE APPLIANCE ON ITS SIDE, YOU MUST WAIT FOR 8 HOURS BEFORE SWITCHING THE APPLIANCE BACK ON.

Aperture dimensions and ventilation requirements

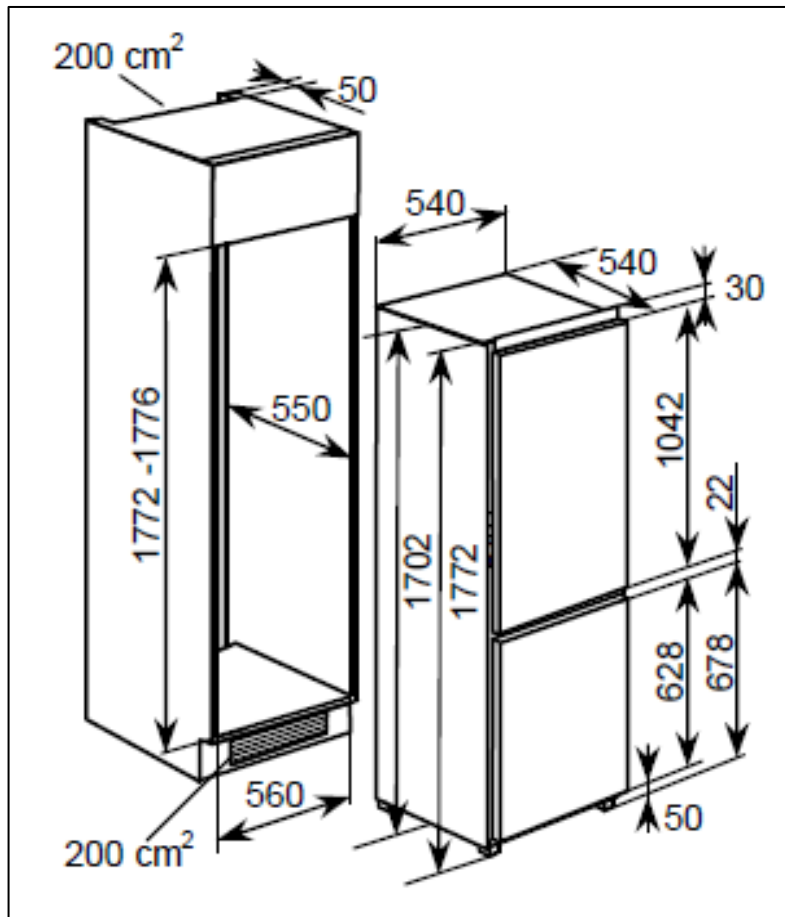

The appliance aperture should be:

Height- 1772-1776 mm

Depth- 550 mm

Width- 560 mm

- If necessary, you should utilise extra filler shelves to fill any additional space that you have in the aperture.
- The diagram on the next page shows the ventilation cut outs needed in order to install the appliance. For the product to operate correctly it is essential to allow adequate air circulation

to cool down the condenser located in the rear part of the appliance.

- The housing unit must be equipped with a rear chimney with an upper opening that must not be blocked and a front slot which should be covered with a ventilation grill.

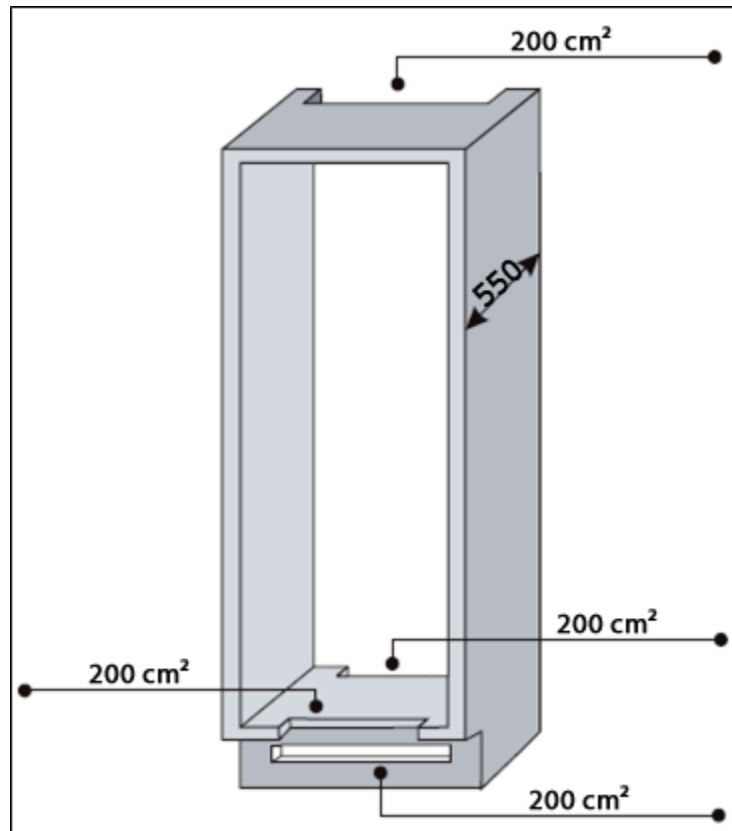

IMPORTANT: The appliance aperture **MUST** have a minimum of 200 cm^2 free air flow for ventilation.

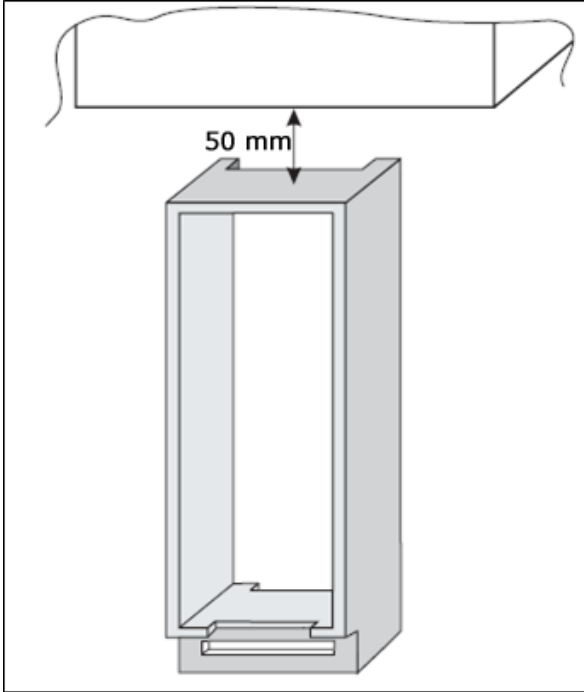

- The diagram on the left shows the minimum gap which should be left between the top of the housing unit and the ceiling to allow sufficient ventilation.

Installing your fridge freezer

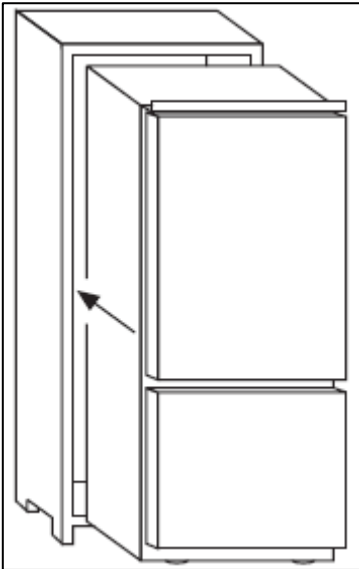

- Insert the appliance into the housing unit, leaving a 5mm gap for the gasket on the opposite side of the hinges.

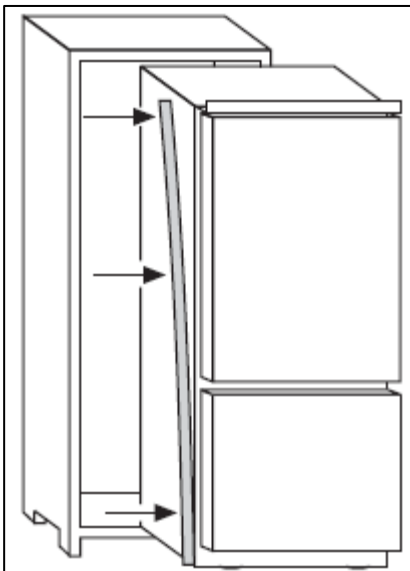

- Fasten the gasket provided into the 5mm gap left opposite the hinges, as outlined in the step above.

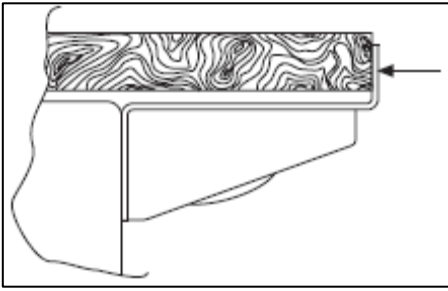

- Make sure the top fixing bracket fits perfectly into the top of the cabinet

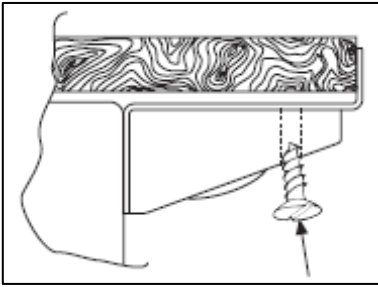

- Fasten the top part of the appliance to the cabinet using the screws provided.

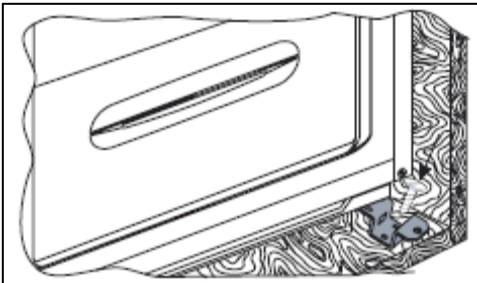

- Fasten the bottom part of the appliance by means of the screws provided.

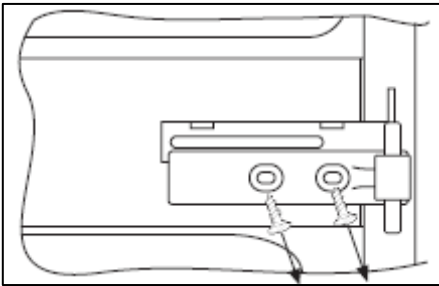

- Loosen the fixing screws of the central right-hand hinge/fixing bracket.

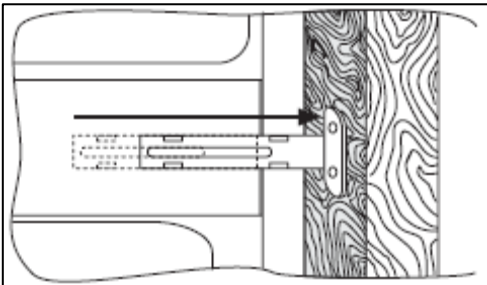

- Position the hinge/fixing bracket close to the housing unit.

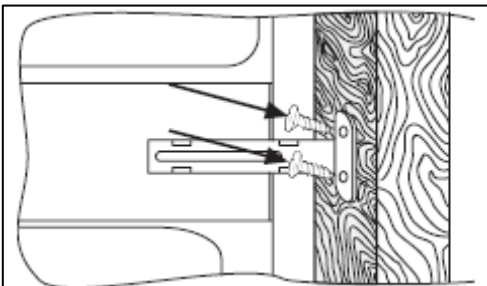

- Screw the hinge/fixing unit to the housing unit by means of the screws provided.

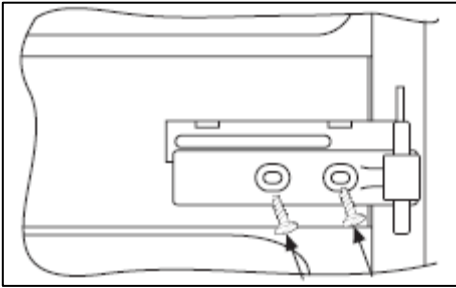

- Tighten the fixing screws of the central right-hand hinge/fixing unit.

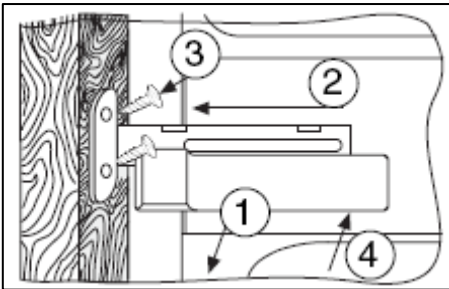

- Perform the same operations on the central left-hand hinge/fixing unit.

Door slider fittings

The appliance is equipped with coupling devices for the appliance doors with the doors of the housing unit.

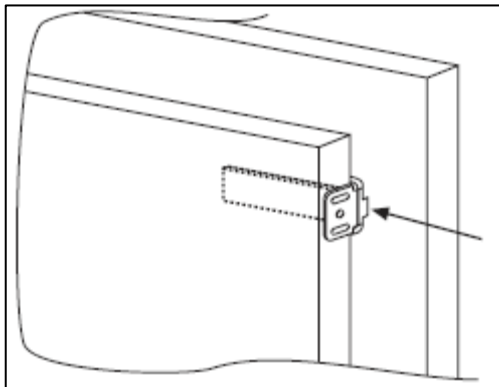

- Open the doors of the built-in housing unit and the fridge. Position the built-in loader in the slide, then fit it into the fridge door.

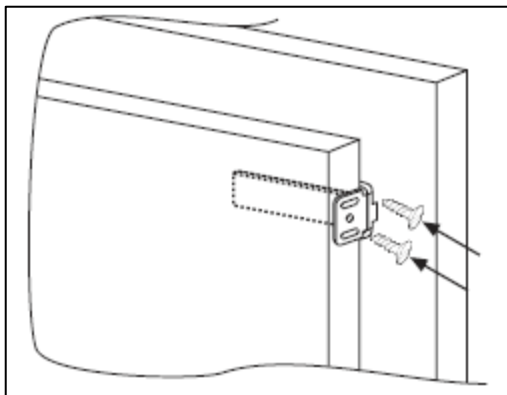

- Connect the appliance door to the cabinet door using the sled slots as a guide.

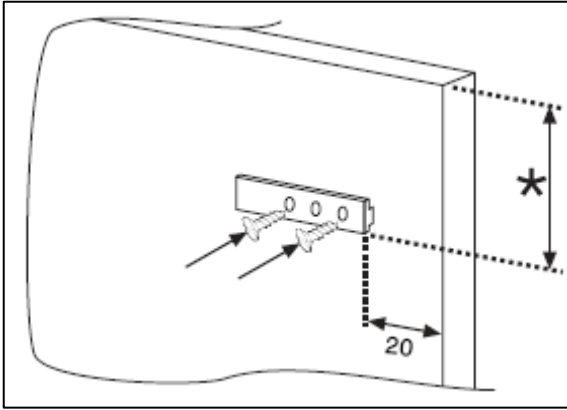

- Fasten the sled in the inner part of the panel of the built-in housing unit at the desired height and at approximately 20 cm from the outer edge of the door. Tighten screws as indicated in the diagram.

When complete, attach screw and slide covers.

Troubleshooting



IMPORTANT: If your fridge freezer appears not to be operating properly, before contacting the Advice Line, please refer to the checklist below.



My fridge freezer does not appear to be working/there is no power to my appliance.

- Check that the plug is fully inserted into the power socket.
- Check that there is power to your mains supply (e.g. that there hasn't been a power cut or that the fuse hasn't blown).
- Check that the thermostat has not been turned to the off position.
- Check that your mains supply voltage, corresponds to the voltage stated on the rating plate of your appliance.



My fridge freezer appears to be performing poorly

- Check that the appliance isn't overloaded and that food hasn't been packed too tightly into it.
- The thermostat setting is too low; you should turn the thermostat up higher.
- Ensure that the door is closing properly and that the door has not been opened for a prolonged period in error.
- Ensure that there is adequate ventilation for your appliance.



My fridge freezer is noisy

- The refrigerant gas that circulates the pipe work of the appliance may make a slight noise, even if the compressor is not running.
- If the noise worsens or the appliance gets louder than normal; check that it is levelled off correctly, that nothing is touching the rear of the fridge freezer and that nothing placed inside the appliance is rattling.



Ice has formed on the inner back wall of my fridge

- Check that food has not been pushed too far back inside the appliance, so that it is in contact with the inner back wall.



There is water in the base of the fridge or leaking out of my fridge.

- Follow the "Defrosting the refrigerator compartment" section on pages 18 - 19.



IMPORTANT: If your appliance appears not to be operating correctly, then you should disconnect it from your mains supply and then contact the Advice Line on telephone number (0118) 933 6918.

DO NOT ATTEMPT TO REPAIR THE APPLIANCE YOURSELF.

Please note that if an engineer is asked to attend whilst the product is under guarantee and finds that the problem is not the result of an appliance fault, then you may be liable for the cost of the call out charge.

The appliance must be accessible for the engineer to perform any necessary repair. If your appliance is installed in such a way that an engineer is concerned that damage will be caused to the appliance or your kitchen, then he will not complete a repair.

This includes situations where appliances have been tiled in, sealed in with sealant, have wooden obstructions placed in front of the appliance, like plinths, or any installation other than the one specified by the manufacturer has been completed.

Please refer to the conditions of guarantee that appear on the warranty card that you receive with the appliance when it is delivered.

Technical Data

Manufacturer	HOMEKING
Model Number	HRCI2570
Product Category	7 – Refrigerator-Freezer
Energy Efficiency Class (1)	A+
Annual Energy Consumption (2)	274 kWh
Storage Volume of Fridge Compartment	188 litres
Storage Volume of Freezer Compartment	62 litres
Star Rating	4
Frost Free Compartments	Fridge
Temperature Rise Time	16 hours
Freezing Capacity	3kg/24hr
Climate Class (3)	ST
Noise Level	42 dB
Installation Type	Built-in

(1) On a scale from A+++ (highest efficiency) to G (lowest efficiency).

(2) Annual energy consumption based on standard test results for 24 hours. The actual energy consumption will depend on how the appliance is used and where it is located.

(3) This appliance is intended to be used at an ambient temperature between "16°C" (lowest temperature) and "38°C" (highest temperature).

United Kingdom

6 Bennet Road,
Reading, Berkshire
RG2 0QX
United Kingdom

Customer Care

(0118) 933 6918