

Under Counter Integrated Freezer

LAM 6400

Installation & Operating Instructions

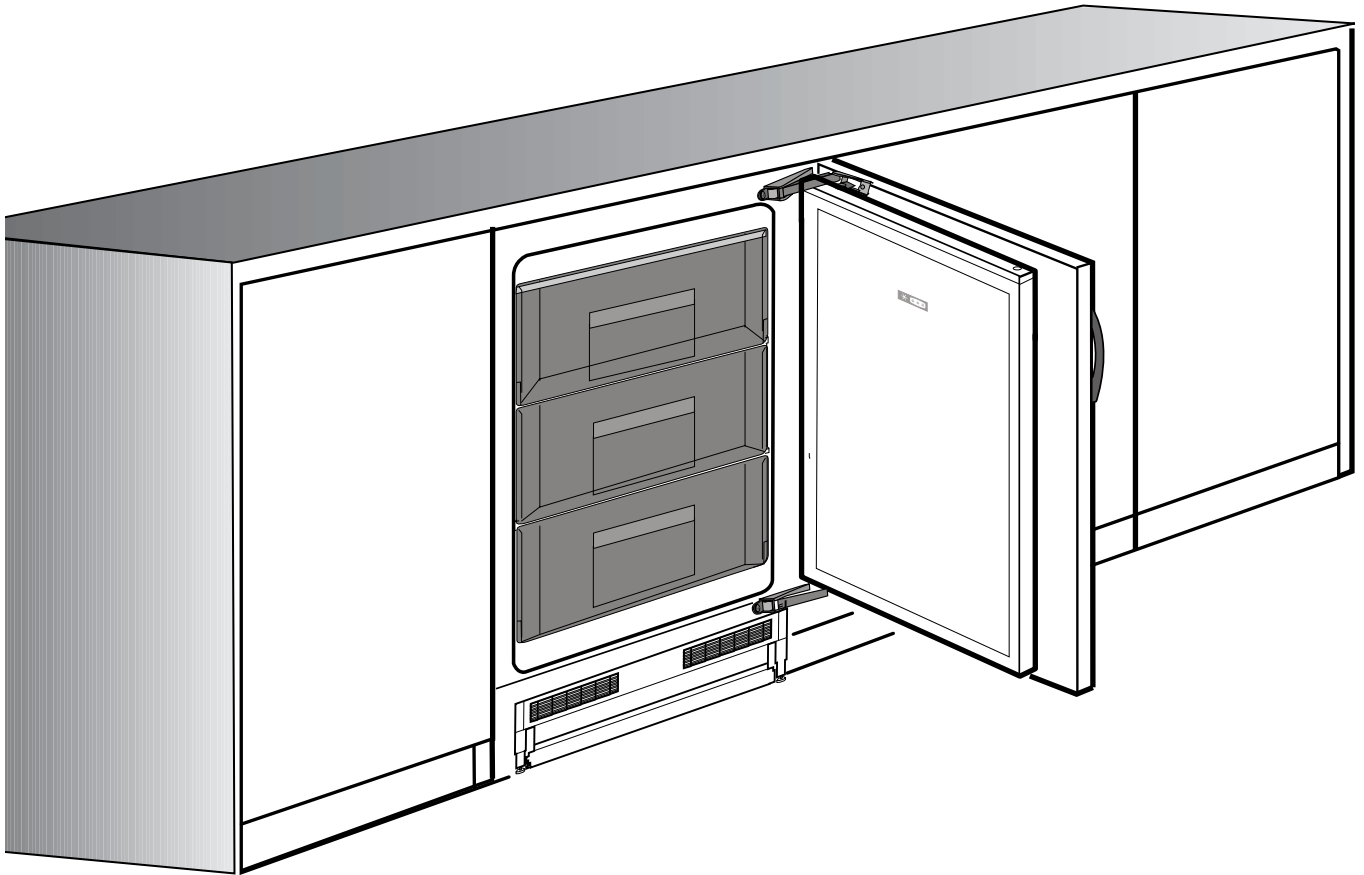

LAMONA

Exclusive to Howdens Joinery Co.

Please read this manual first!

Dear Customer,

We hope that your product, which has been produced in a modern factory and checked under the most meticulous quality control procedures, will provide you with years of good service.

- This manual will help you use your appliance quickly and safely.
- Read the manual before installing and operating your product.
- Follow the instructions, especially those about safety warnings.
- Keep the manual in an easily accessible place as you may need it later.
- Also read the other documents provided with your product.

Symbols and their descriptions

This instruction manual contains the following symbols:



Important information or useful usage tips.



Warning against dangerous conditions for life and property.



Warning against electric voltage shock.

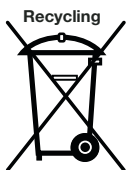

This product is supplied with the selective sorting symbol for waste electrical and electronic equipment (WEEE).

This means that this product must be handled pursuant to European Directive 2002/96/EC in order to be recycled or dismantled to minimise its impact on the environment. For further information, please contact your local or regional authorities.

Electronic products not included in the selective sorting process are potentially dangerous for the environment and human health due to the presence of hazardous substances.

CONTENTS

1 Your refrigerator	3	4 Before operating	19
		Important Notes :	19
2 Warnings	4	5 Using your refrigerator	20
ELECTRICAL REQUIREMENTS	5	Temperature setting button.....	20
WARNING! THIS APPLIANCE MUST BE EARTHED	5	Storing the frozen food	20
ENERGY SAVING TIPS.....	6	Defrosting	20
		LED indicators and control panel	21
3 Installation	7	6 Maintenance and cleaning	22
Points to be considered when re- transporting your refrigerator	7	7 Do's and Don'ts	23
Before operating your refrigerator ...	7		
Electric connection	7	8 Guarantee Details	25
Disposing of the packaging	7		
Disposing of your old refrigerator	8		
Placing and Installation	8		
REVERSING THE DOORS	11		
INSTALLATION INSTRUCTIONS - DETAILED STEP BY STEP	13		

1 Your refrigerator

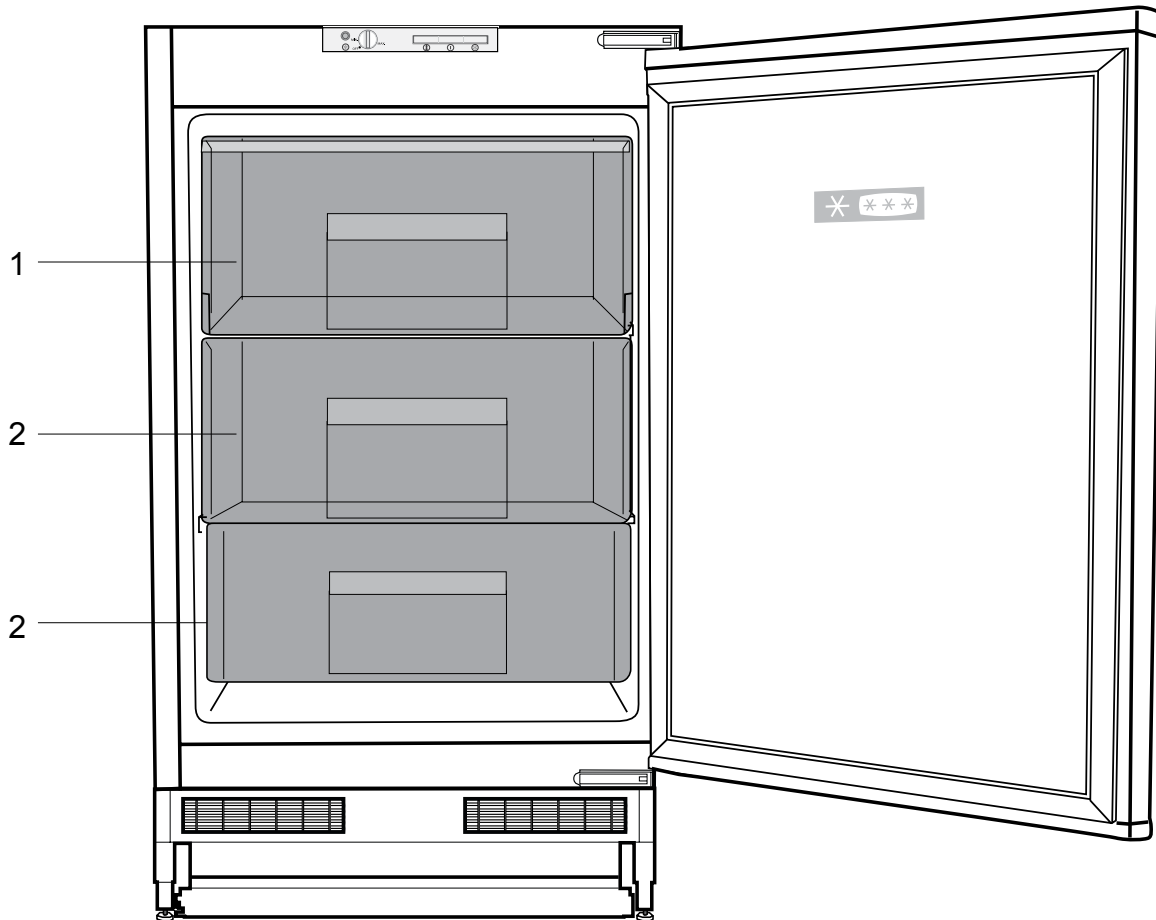

- 1- Fast freeze compartment
- 2- Frozen food compartments

Figures that take place in this instruction manual are schematic and may not correspond exactly with your product. If the subject parts are not included in the product you have purchased, then it is valid for other models.

2 Warnings

- DO NOT connect your appliance to the electricity supply until all packing and transit protectors have been removed.
- Leave to stand for at least 4 hours before switching on to allow compressor oil to settle if transported horizontally.
- If you are discarding an old refrigerator with a lock or latch fitted to the door, disable the lock/latch, ensure that it is left in a safe condition to prevent the entrapment of young children.
- This fridge/freezer must only be used for its intended purpose i.e the storing and freezing of edible foodstuff.
- Do not dispose of the appliance on a fire. This appliance which is among the latest range introduced is particularly environment friendly. Your appliance contains non CFC / HFC natural substances in the cooling system (Called R600a) and in the insulation (Called cyclopentane) which are potentially flammable if exposed to fire. Therefore, take care not to damage, the cooling circuit / pipes of the appliance in transportation and in use. In case of damage do not expose the appliance to fire or potential ignition source and immediately ventilate the room where the appliance is situated.
- We suggest you contact your local authority for disposal information and facilities available.
- See Installation Instructions on page 8 for information on suitable location.
- To obtain the best possible performance and trouble free operation from your appliance it is very important to carefully read these instructions.
- On delivery, check to make sure that the product is not damaged and that all the parts and accessories are in perfect condition.
- Ensure that the plug remains readily accessible. Do not use multiple adapter bar or extension cable.
- Failure to observe these instructions may invalidate your right to free service during the guarantee period.
- Keep ventilation openings, in the appliance enclosure or in the built-in structure, clear of obstruction.
- Do not use mechanical devices or other means to accelerate the defrosting process, other than those recommended by the manufacturer.
- Do not damage the refrigerant circuit.
- Do not use electrical appliances inside the food storage compartments of the appliance, unless they are of the type recommended by the manufacturer.
- We suggest you keep these instructions in a safe place for easy reference.
- This appliance is not intended for use by persons (including children) with reduced physical, sensory or mental capabilities, or lack of experience and knowledge, unless they have been given supervision or instruction concerning use of the appliance by a person responsible for their safety.
- Children should be supervised to ensure that they do not play with the appliance.

ELECTRICAL REQUIREMENTS

Before you insert the plug into the wall socket make sure that the voltage and the frequency shown on the rating plate inside the appliance corresponds to your electricity supply.

Rating label is on the left hand side of fridge inner liner.

We recommend that this appliance be connected to the mains supply via a suitable switched and fused socket. The appliance must be positioned so that the plug is accessible.

Should the mains lead of the appliance become damaged or should it need replacing at any time, it must be replaced by a special purpose made mains lead which can only be obtained from a **LAMONA** Authorised Service Agent.

WARNING! THIS APPLIANCE MUST BE EARTHED

If the fitted moulded plug is not suitable for your socket, then the plug should be cut off and an appropriate plug fitted. Destroy the old plug which is cut off as a plug with bared cord could cause a shock hazard if inserted into a socket elsewhere in the house. The moulded plug on this appliance incorporates a 13 A fuse. Should the fuse need to be replaced an ASTABEAB approved BS 1362 fuse of the same rating must be used. Do not forget to refit the fuse cover. In the event of losing the fuse cover the plug must not be used until a replacement fuse cover has been fitted.

IMPORTANT! FITTING A DIFFERENT PLUG

As the colours of the wires in the mains lead of this appliance may not correspond with the coloured markings identifying the terminals in your plug proceed as follows: (See diagram).

1. Connect the green-yellow or green (Earth) wire to the terminal in the plug marked 'E' or with the symbol  or coloured green and yellow or green.
2. Connect the blue (Neutral) wire to the terminal in the plug marked 'N' or coloured black.
3. Connect the brown (Live) wire to the terminal in the plug marked 'L' or coloured red.

With alternative plugs a 13 A fuse must be fitted either in the plug or adaptor or in the main fuse box. If in doubt contact a qualified electrician.

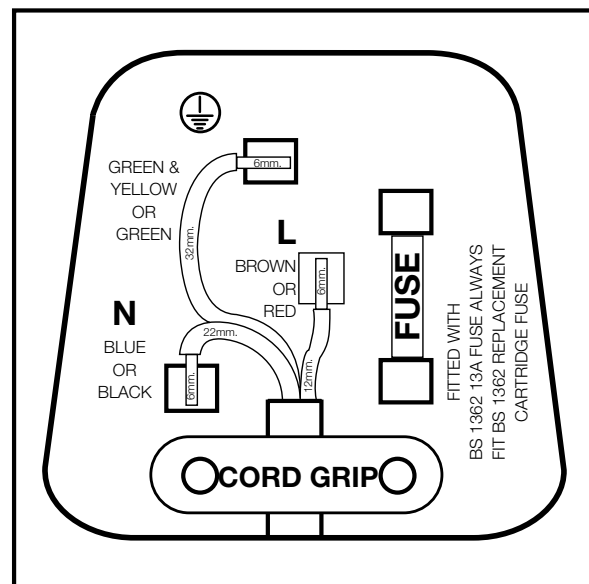

ENERGY SAVING TIPS

1- Ensure your appliance is installed in a well ventilated area.

2- Ensure the time between buying chilled/frozen food and placing them in your appliance is kept to a minimum, particularly in summer. We recommend you use a cool bag or a special carrier bag to carry frozen food.

3- Do not leave the door (s) of your appliance open longer than necessary and ensure they are closed properly after each opening.

4- Defrost frozen food in the fridge compartment, so that frozen food acts as an ice pack to assist cooling in the fridge.

3 Installation

⚠ Please remember that the manufacturer shall not be held liable if the information given in the instruction manual is not observed.

Points to be considered when re-transporting your refrigerator

1. Your refrigerator must be emptied and cleaned prior to any transportation.
2. Shelves, accessories, crisper and etc. in your refrigerator must be fastened securely by adhesive tape against any jolt before repackaging.
3. Packaging must be tied with thick tapes and strong ropes and the rules of transportation printed on the package must be followed.

Please do not forget...

Every recycled material is an indispensable source for the nature and for our national resources.

If you wish to contribute to recycling the packaging materials, you can get further information from the environmental bodies or local authorities.

Before operating your refrigerator

Before starting to use your refrigerator check the following:

1. Is the interior of the refrigerator dry and can the air circulate freely in the rear of it?
2. Clean the interior of the refrigerator as recommended in the "Maintenance and cleaning" section.
3. Plug the refrigerator into the wall outlet. When the fridge door is open, the fridge compartment interior light will come on.
4. You will hear a noise as the compressor starts up. The liquid and

gases sealed within the refrigeration system may also give rise to noise, even if the compressor is not running and this is quite normal.

5. Front edges of the refrigerator may feel warm. This is normal. These areas are designed to be warm to avoid condensation

Electric connection

Connect your product to a grounded socket which is being protected by a fuse with the appropriate capacity.

Important:

- The connection must be in compliance with national regulations.
- The power cable plug must be easily accessible after installation.
- The specified voltage must be equal to your mains voltage.
- Extension cables and multiway plugs must not be used for connection.

⚠ A damaged power cable must be replaced by a qualified electrician.

⚠ Product must not be operated before it is repaired! There is danger of electric shock!

Disposing of the packaging

The packing materials may be dangerous for children. Keep the packing materials out of the reach of children or dispose of them by classifying them in accordance with the waste instructions. Do not dispose of them along with the normal household waste.

The packing of your refrigerator is produced from recyclable materials.

Disposing of your old refrigerator

Dispose of your old refrigerator without giving any harm to the environment.

- You may consult your authorised dealer or waste collection center of your municipality about the disposal of your refrigerator.

Before disposing of your refrigerator, cut out the electric plug and, if there are any locks on the door, make them inoperable in order to protect children against any danger.

Placing and Installation

⚠ If the entrance door of the room where the refrigerator will be installed is not wide enough for the refrigerator to pass through, then call the authorised service to have them remove the doors of your refrigerator and pass it sideways through the door.

1. Install your refrigerator to a place that allows ease of use.
2. Keep your refrigerator away from heat sources, humid places and direct sunlight.
3. There must be appropriate air ventilation around your refrigerator in order to achieve an efficient operation. If the refrigerator is to be placed in a recess in the wall, there

must be at least 5 cm distance with the ceiling and at least 5 cm with the wall. If the floor is covered with a carpet, your product must be elevated 2.5 cm from the floor.

4. Place your refrigerator on an even floor surface to prevent jolts.
5. Do not keep your refrigerator in ambient temperatures under 10°C.

IMPORTANT INSTALLATION INSTRUCTIONS

1. To avoid a hazard due to instability of the appliance, it must be fixed in accordance with the instructions.
2. Do not operate this appliance unless installed to furniture.
3. The appliance should be located on a smooth surface. The four front and back feet can be adjusted as required. To ensure that, your appliance is standing upright adjust the four front and back feet by turning clockwise or anti-clockwise, until the product is in firm contact with the floor. Correct adjustment of feet avoids excessive vibration and noise.
4. Refer to «Cleaning and Care» section to prepare your appliance for use.
To avoid any loss in performance, air suction channels should not be obstructed. (140 cm²)

Minimum distance between the wall and the appliance must be at least 10 mm.

5. The appliance must be protected against rain, moisture and other atmospheric influences.

IMPORTANT: Care must be taken” while cleaning / carrying the appliance to avoid touching the bottom of the condenser metal wires at the back of the appliance as you might injure your fingers and hands.

IMPORTANT: This appliance is” not designed for stacking with any other appliance. When positioning your appliance, take care not to damage your flooring, pipes, wall coverings etc.

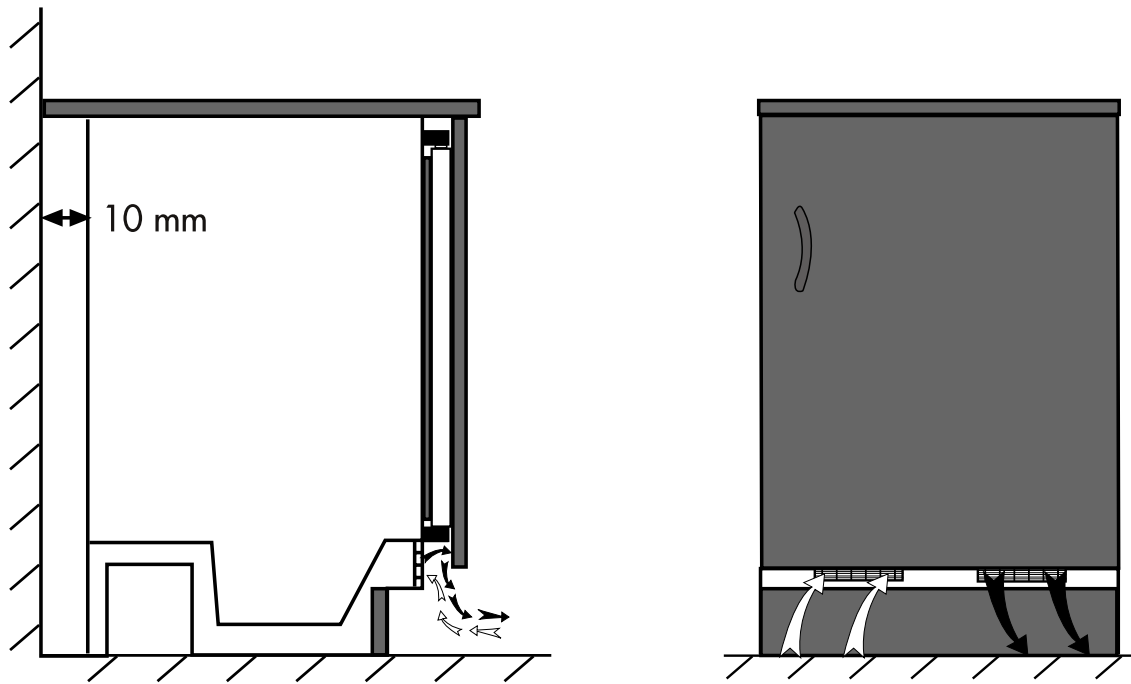

To avoid any loss in performance, air suction channels should not be obstructed.
(140 cm²)

Minimum distance between the wall and the appliance must be at least 10 mm.

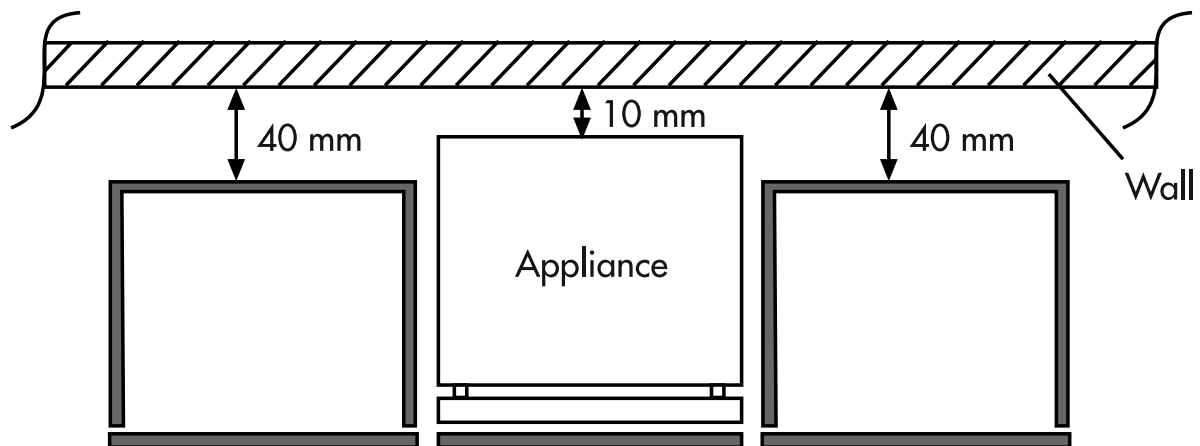

REVERSING THE DOORS

Follow the step by step instructions and the diagram below. Numbers in brackets refer to diagrams.

1. Switch off at the socket outlet and pull out the mains plug.
 2. Remove all food, loose items and fittings from inside the appliance and door shelves.
 3. Unscrew the bolts and remove the upper and bottom hinges from the cabinet and door. (1) (2)
 4. Remove stoppers. (3) (4)
 5. Fit the stoppers on the opposite side. (5) (6)
 6. Reposition the upper hinge on the opposite side as bottom hinge (7)
 7. Reposition the bottom hinge on the opposite side as upper hinge. (8)
- Locate the door and tighten the bolts fixing the door.

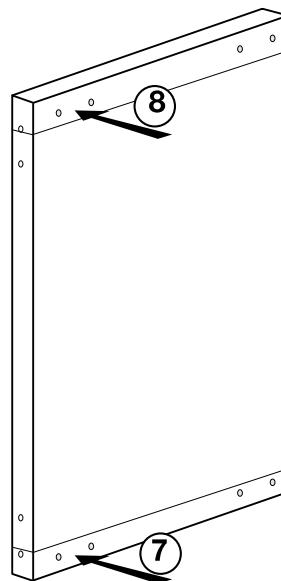
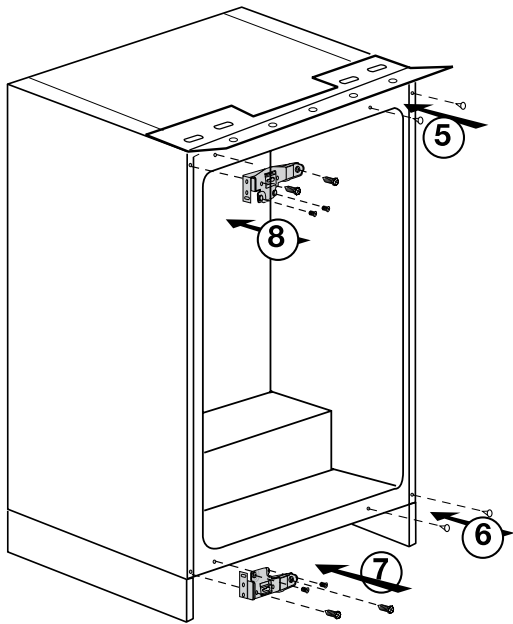
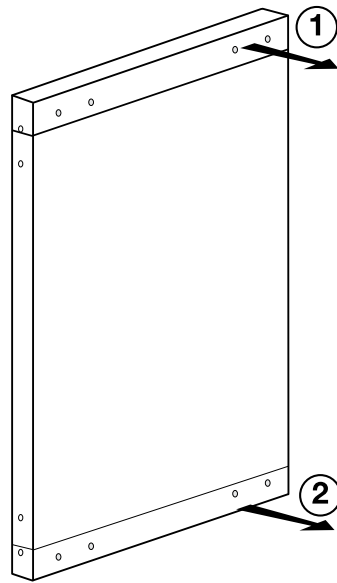
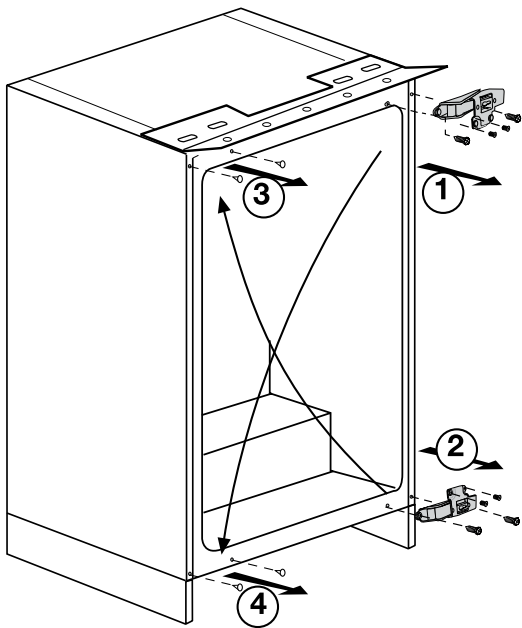

INSTALLATION INSTRUCTIONS - DETAILED STEP BY STEP

Torx Wood Plastic Sheet

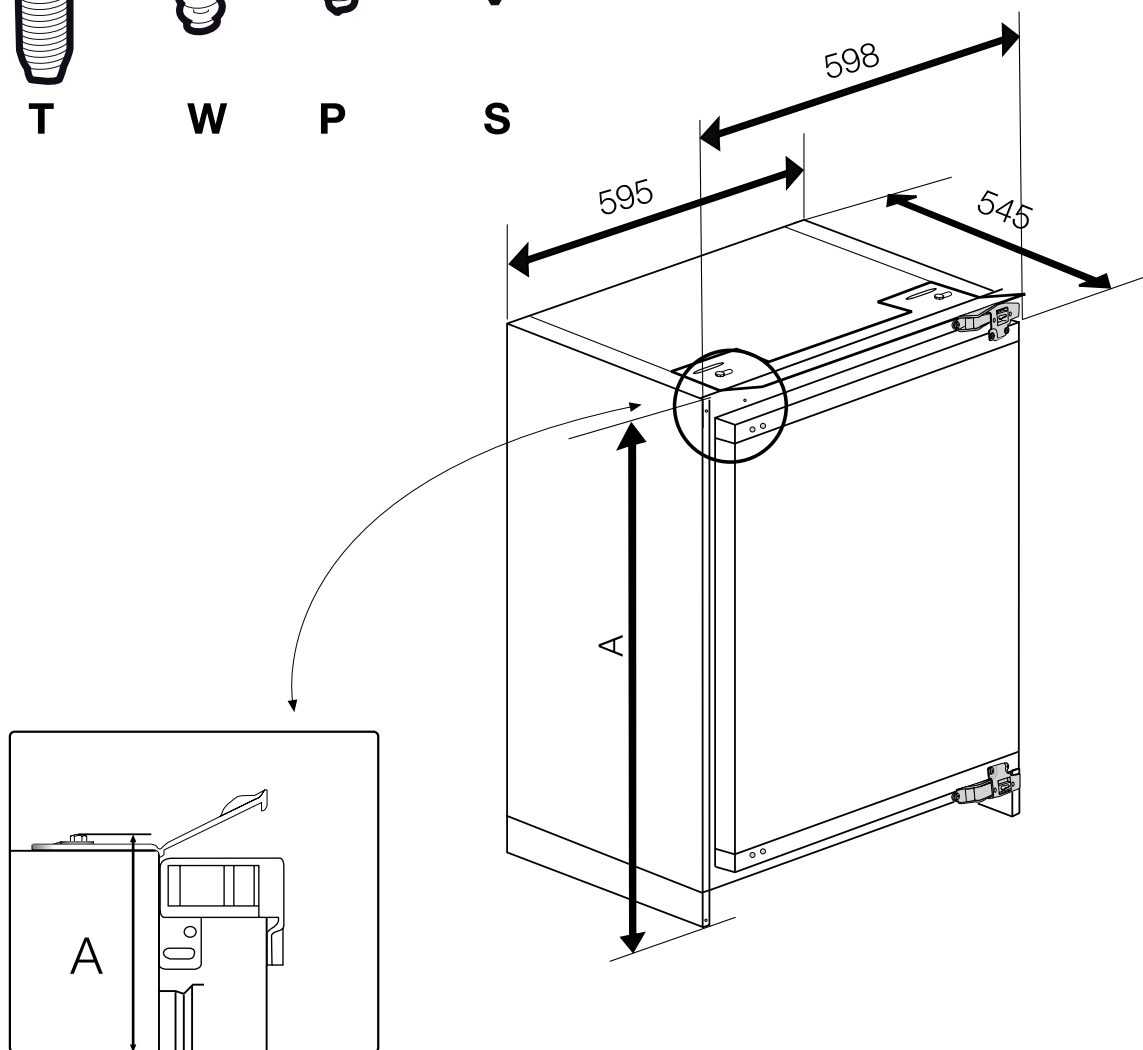
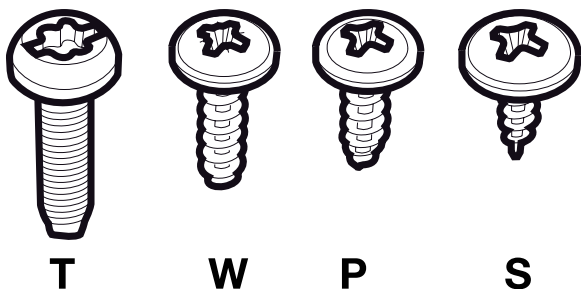

A (mm)	820 - 870 mm
C (mm)	100 - 150 mm

Note

- 1) Height of the product can be adjusted by the help of adjustable feet (front and back) to fit the furniture niche height (B).
- 2) Do not operate this appliance until it has been installed in the furniture.

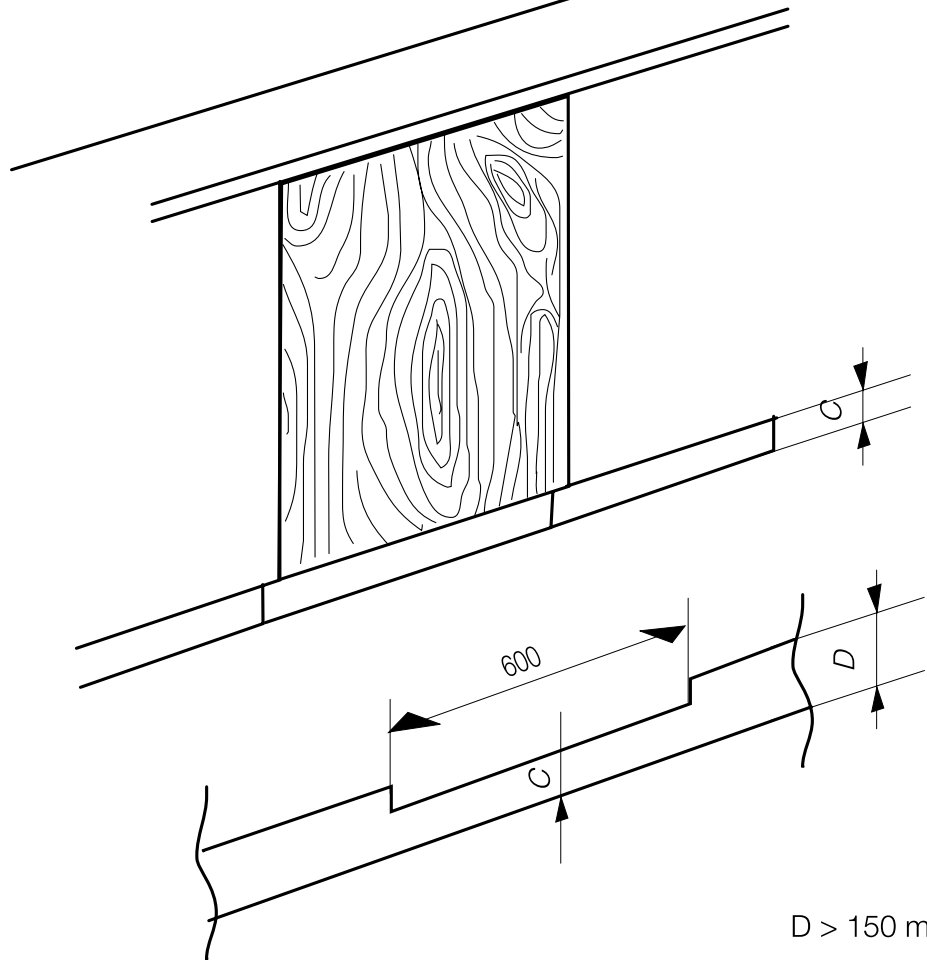
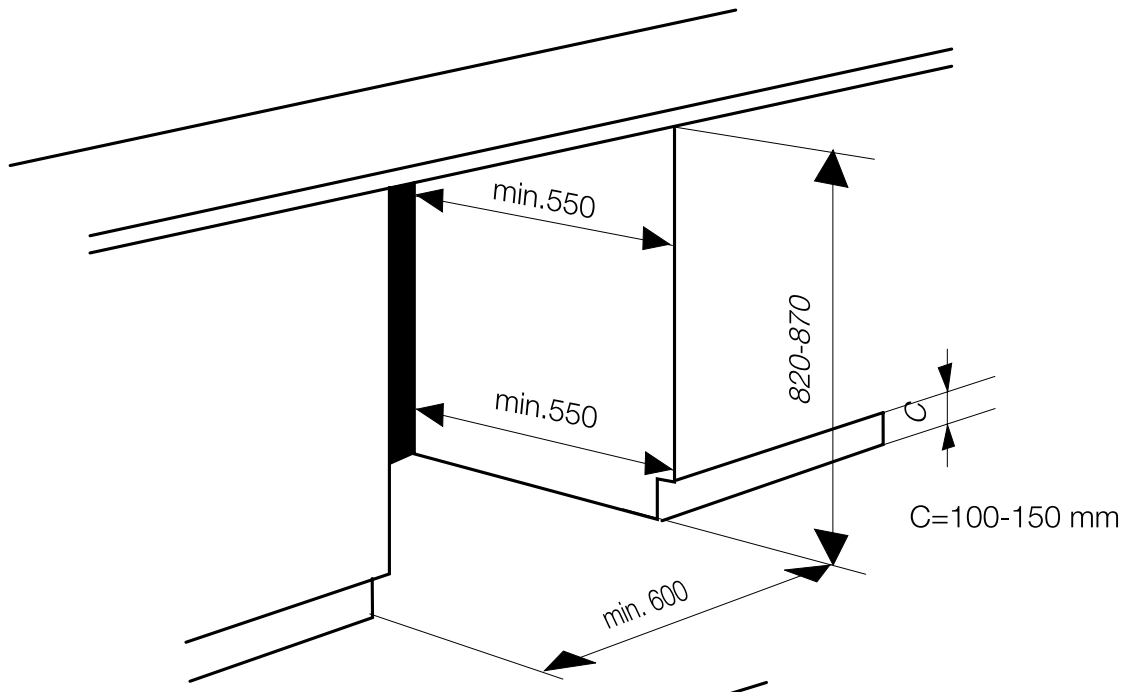

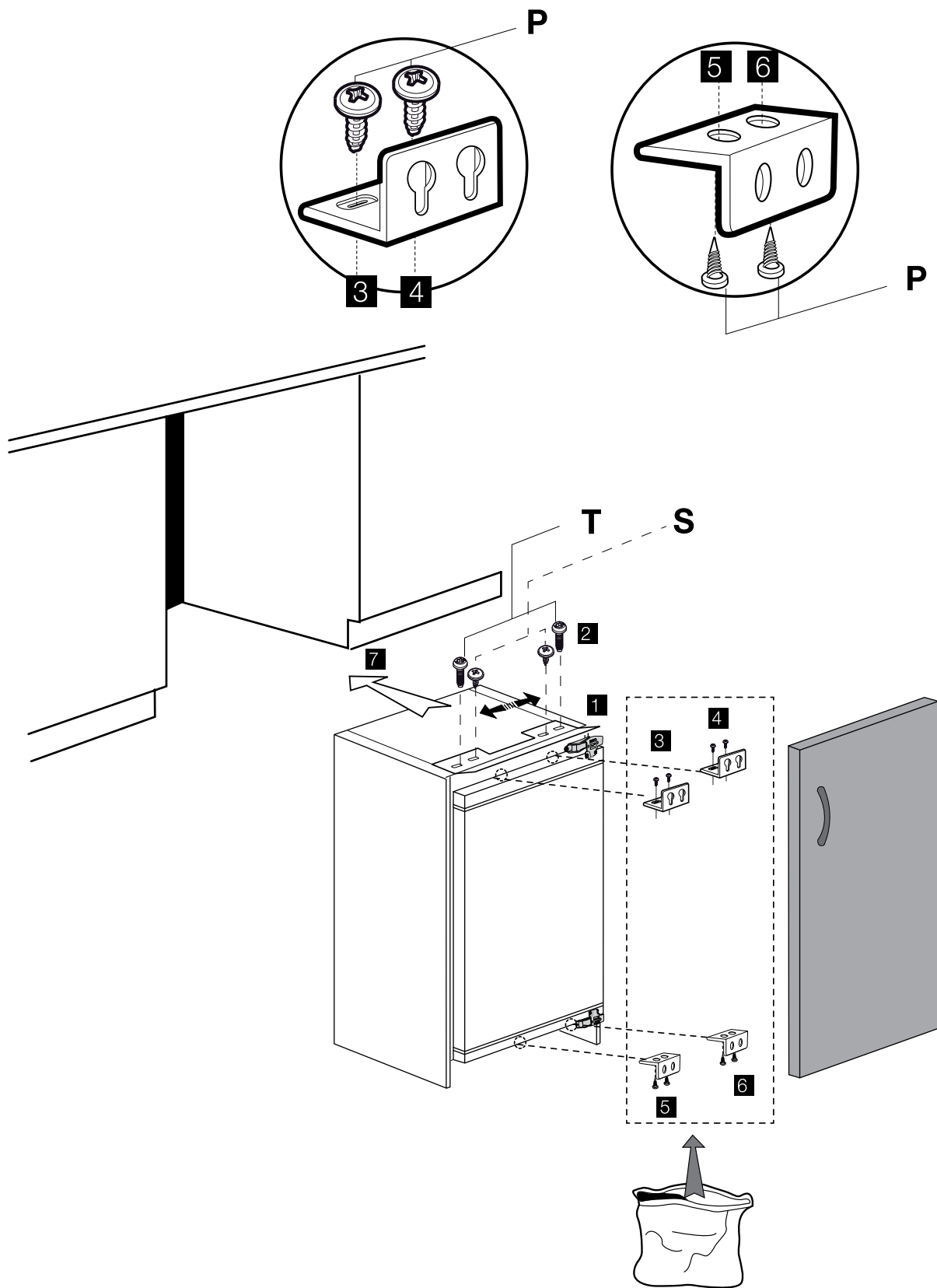

Note: Installation step for 2, screws for connecting top plastic rpart should not be screwed very **hard** because of moving the plastic part easily left or right side.

Top view

E = 1,5 mm is recommended.

Front view

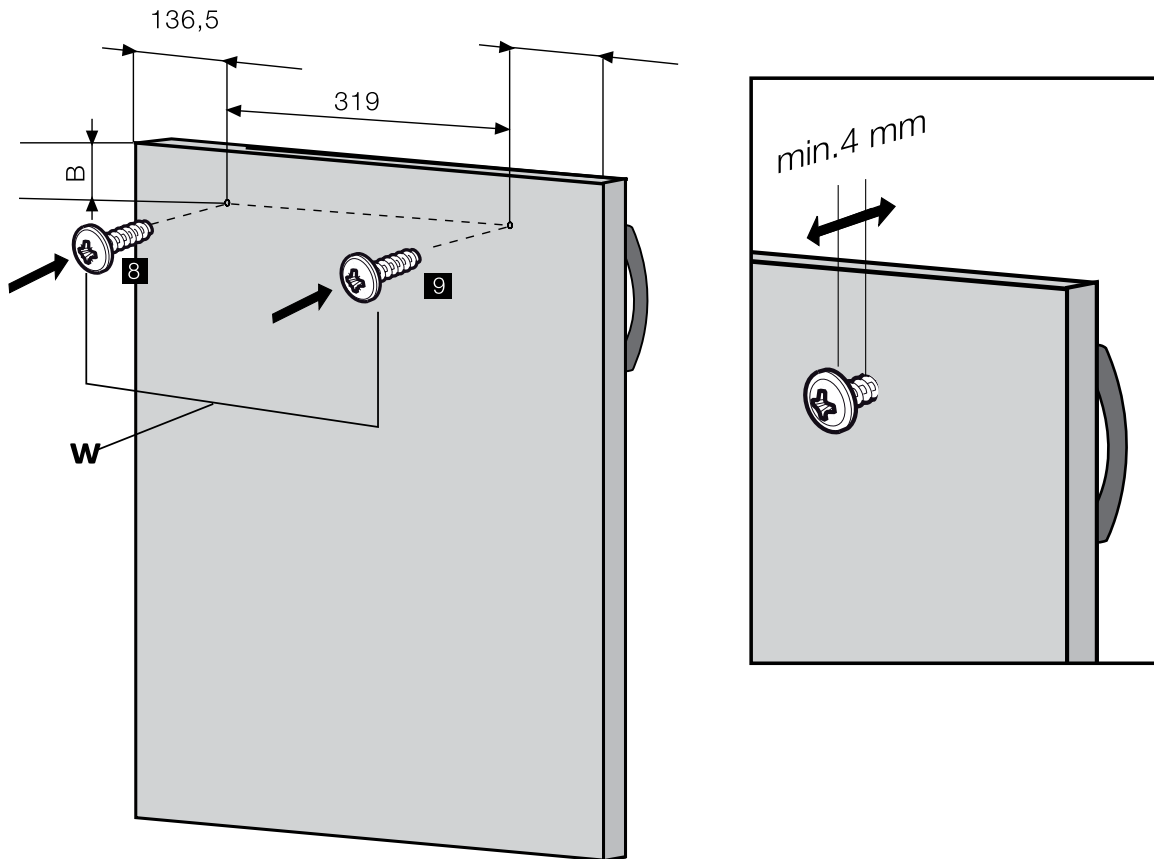
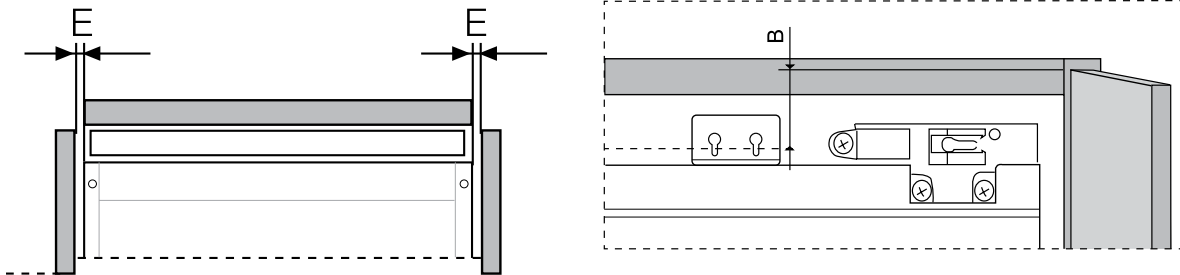

Note:

1. These dimensions are valid for products, which are hinged on right hand side.
2. When door opening direction is reversed, mirror image of this instruction should be considered. That is, dimensions should be considered for opposite sides.

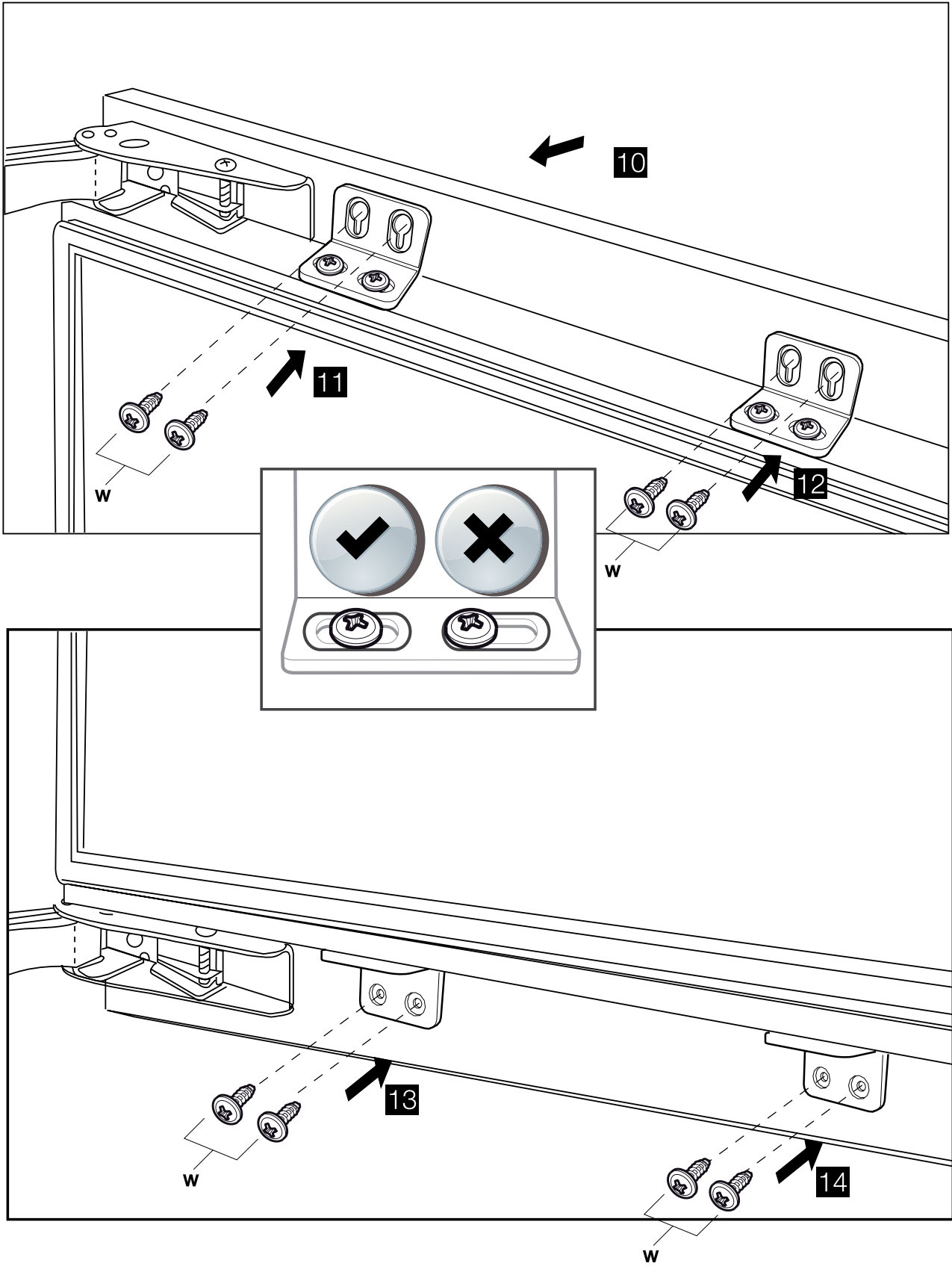

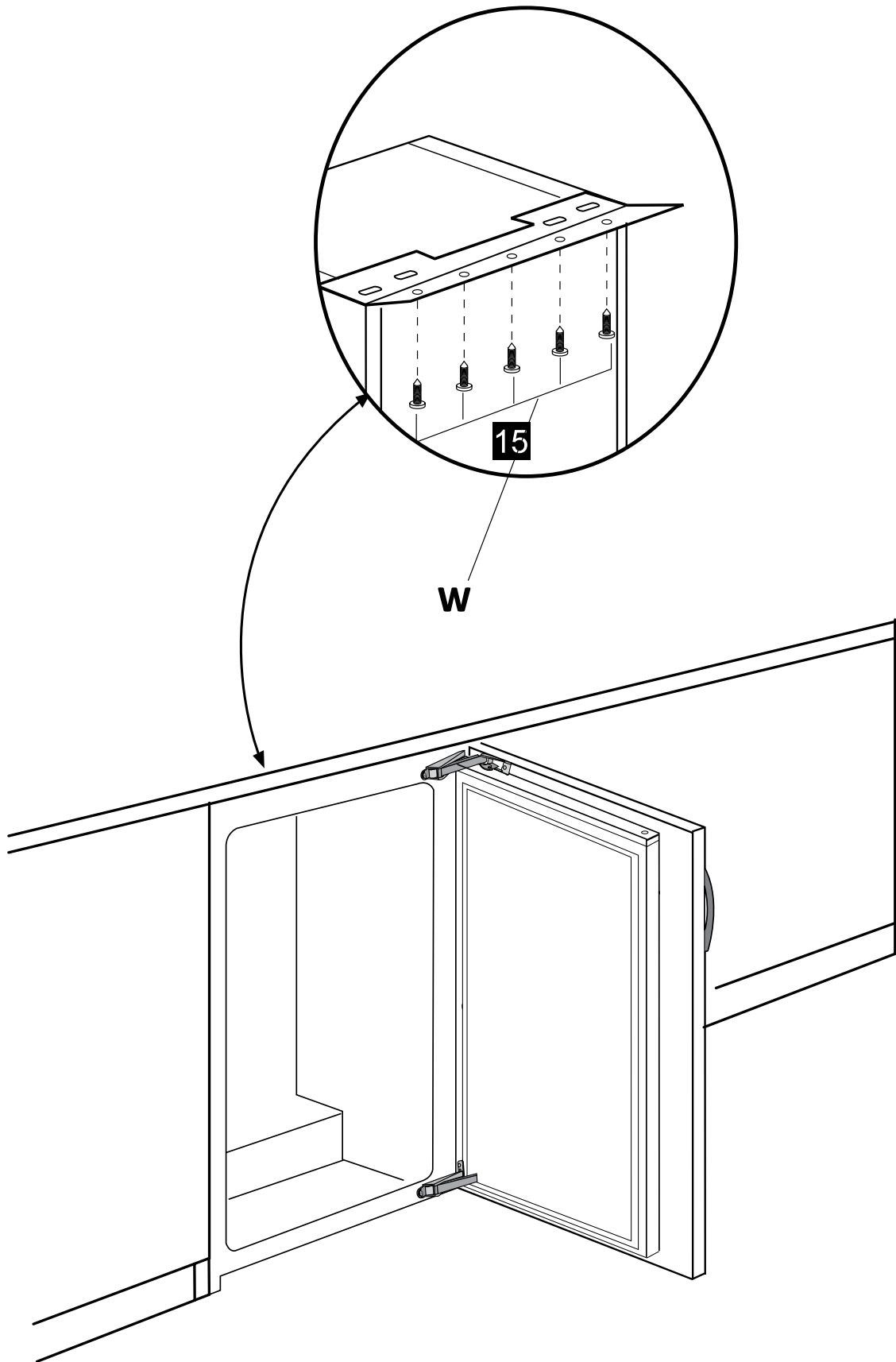

4 Before operating

Final Check

Before you start using the freezer check that:

1. The feet have been adjusted and the product is level.
2. The interior is dry and air can circulate freely at the rear.
3. Clean the interior as recommended under "CLEANING AND CARE."
4. Insert the plug into the wall socket and switch on the electricity supply. Avoid accidental disconnection by taping over the switch.
5. You will hear a noise as the compressor starts up. The liquid and gases sealed within the refrigeration system may also give rise to noise, whether the compressor is running or not which is quite normal.
7. Front edges of the cabinet may feel warm. This is normal. These areas are designed to be warm to avoid condensation.
9. Do not load the appliance immediately it is switched on. Wait until the correct storage temperature has been reached. We recommend that you check the temperature with an accurate thermometer (see; Temperature Control and Adjustment).

Important Notes :

1. If there is a power failure do not open the door. Frozen food should not be affected if the failure lasts for less than 19 hours. If the failure is longer, then the food should be checked and either eaten immediately or cooked and then re-frozen.
2. If you find the freezer door difficult to open just after you have closed it, don't worry. This is due to the pressure difference which will equalise and allow the door to open normally after a few minutes.
3. Always wrap food using a suitable packaging material before storing in your appliance to avoid contact with the appliance surface and food remains for hygiene reasons.
4. The appliance may go to OFF position when the knob is adjusted below MIN. When the green indicator light is OFF, the appliance is turned OFF also.
Once it is turned OFF (even for defrosting), please adjust the knob somewhere above MIN to be sure that it is turned ON again. When the appliance is turned ON, the green indicator will light up.

5 Using your refrigerator

Temperature setting button



The interior temperature of your refrigerator changes for the following reasons;

- Seasonal temperatures,
- Frequent opening of the door and leaving the door open for long periods,
- Food put into the refrigerator without cooling down to the room temperature,
- The location of the refrigerator in the room (e.g. exposing to sunlight).

You may adjust the varying interior temperature due to such reasons by using the thermostat. If the ambient temperature is higher than 32°C, turn the thermostat button to maximum position.

Storing the frozen food

Prepacked commercially frozen food should be stored in accordance with the frozen food manufacturer's instructions for a   frozen food storage compartment.

The freezing area is marked with   symbol on the door liner.

To ensure that the high quality achieved by the frozen food manufacturer and the food retailer is maintained the following should be remembered:

1. Put packets in the freezer as quickly as possible after purchase.
2. Do not exceed "Use By", "Best Before" dates on the packaging.
3. Please note that drawers, baskets, flaps, trays are all removable.

Defrosting

Defrost twice a year or when a frost layer of around 7 mm (1/4") has formed.

To start defrosting procedure turn the thermostat knob to zero position (Alternatively you may switch off the freezer at the socket outlet and pull out the mains plug.)

All food should be wrapped in several layers of newspaper and stored in a cool place (e.g. fridge or larder).

Remove all freezer drawers. The special defrost collection basin collects the defrost water. Therefore defrosting can be conducted without mess.

Containers full of warm water may be placed carefully in the freezer to speed up the defrosting.

Do not use pointed or sharp edged objects such as knives, forks to remove the frost.

Never use hairdryers, electrical heaters and other similar electrical appliances for defrosting.

When defrosting has finished, sponge out any defrost water which collects at the bottom of the freezer and dry the interior thoroughly. Turn the thermostat knob to mid point. Close the freezer door. Insert the plug into the wall socket and switch on the electricity supply. Don't forget to tape over the switch to avoid accidental disconnection.

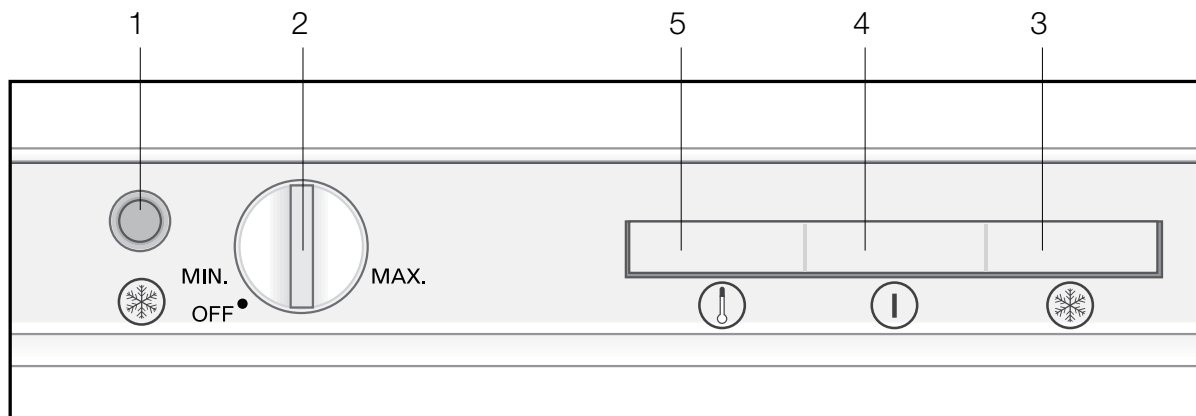

LED indicators and control panel

LED indicators in the front section of your refrigerator are intended to help you in monitoring the operation of your appliance.

Keep your food in the refrigerator in a safe manner by monitoring and using these LEDs and controls as explained below:

Fast Freeze Button (1): Used to freeze the food fastly. Compressor may not operate immediately but after some time when the button is pressed and this is quite normal.

Thermostat Setting Button (2): Used to set your refrigerator between minimum and maximum values.

Orange LED (3): Lights up when the fast freeze button on the LED panel is pressed. In this case, your refrigerator operates continuously.

Press the button again when the food you would like to fast freeze comes to the desired temperature and the orange LED will turn off.

Green LED (4): Lights up continuously after plugging in your refrigerator.

Red LED (5): It warns you by lighting up continuously when your refrigerators start to operates, if not enough cooling effect is obtained, when the door remains open for a long time and when excessive food is loaded.

If the red LED lights up continuously when the conditions stated in the adjacent column do not exist, then call our Authorized Service.

6 Maintenance and cleaning

** We recommend that you switch off the appliance at the socket outlet and pull out the mains plug before cleaning.

** Never use any sharp abrasive instrument, soap, household cleaner, detergent and wax polish for cleaning.

** Use luke warm water to clean the cabinet of the appliance and wipe it dry.

Use a damp cloth wrung out ** in a solution of one teaspoon of bicarbonate of soda to one pint of water to clean the interior and wipe it .dry

** Excess deposit of ice should be removed on a regular basis using the handle of a spoon. Large accumulation of ice will impair the performance of the freezer.

** If the freezer is not going to be used for a long period of time switch it off,remove all food, clean it and leave the door ajar.

** To remove a drawer, pull it as far as possible, and then tilt it upwards, and then pull it out completely.

** Any dust that gathers on the condenser, which is located at the back of the freezer, should be removed once a year with a vacuum cleaner.

Check door seals regularly to ensure ** they are clean and free from food ..particles

** Never :
Clean the worktop with unsuitable material; eg petroleum based .products
Subject it to hot temperatures in any way, Scour, rub etc., with abrasive .material

7 Do's and Don'ts

Do- Clean your appliance regularly (See "Cleaning and Care")

Do- Keep raw meat and poultry below cooked food and dairy products.

Do- Take off any unusable leaves on vegetables and wipe off any soil.

Do- Leave lettuce, cabbage, parsley and cauliflower on the stem.

Do- Wrap cheese firstly in greaseproof paper and then in a polythene bag excluding as much air as possible. For best results take out of the fridge compartment an hour before eating.

Do- Wrap raw meat and poultry loosely in polythene or aluminium foil. This prevents drying.

Do- Wrap fish and offal in polythene bags.

Do- Wrap food which have a strong odour or can dry out in polythene bags, aluminium foil or place in an airtight container.

Do- Wrap bread well to keep it fresh.

Do- Chill white wines, beer, lager and mineral water before serving.

Do- Check contents of the freezer every so often.

Do- Keep food for as short a time as possible and adhere to "Best Before", "Use by" etc. dates.

Do- Store commercially frozen food in accordance with the instructions given on the packets that you buy.

Do- Always choose high quality fresh food and be sure it is thoroughly clean before you freeze it.

Do- Prepare fresh food for freezing in small portions to ensure rapid freezing.

Do- Wrap all food in aluminium foil or freezer quality polythene bags and make sure any air is excluded.

Do- Wrap frozen food when you buy it and put it in to the freezer as soon as possible.

Do- Defrost food in the fridge compartment.

Do- Remove ice cream from the freezer 10-20 minutes before serving.

Don't- Store bananas in your fridge compartment.

Don't- Store melon in your fridge. It can be chilled for short periods as long as it is wrapped to avoid it flavouring other food.

Don't- Store poisonous or any dangerous substances in your appliance. It has been designed for the storage of edible foodstuffs only.

Don't- Consume food which has been stored for an excessive time in the fridge.

Don't- Store cooked and fresh food together in the same container. They should be packaged and stored separately.

Don't- Let defrosting food or food juices drip onto food.

Don't- Leave the door open for long periods as this will make the appliance more costly to run and cause excessive ice formation.

Don't- Put hot food into the appliance. Let it cool down first.

Don't- Put liquid-filled bottles or sealed cans containing carbonated liquids into the freezer as they may burst.

Don't- Exceed the maximum freezing loads (6 kg in any 24 hours) when freezing fresh food.

Don't- Give children ice-cream and water ices direct from the freezer. The low temperature may cause 'freezer burns' on lips.

Don't- Freeze fizzy drinks.

Don't- Try to keep frozen food which has thawed, it should be eaten within 24 hours or cooked and refrozen.

Don't- Remove items from the freezer with wet hands.

Don't- Close the freezer door before placing the compartment cover in its place.

Don't- Leave frozen food at room temperature to thaw; the best way to defrost food is to put it in the fridge to thaw slowly. Make sure you avoid defrosting food or food juices drip onto other food.

PROBLEM SOLVING

If the appliance does not operate when switched on, check whether:

- The plug is inserted properly in the socket and that the power supply is on. (To check the power supply to the socket, plug in another appliance)
- The fuse has blown/circuit breaker has tripped/main distribution switch has been turned off.
- The temperature control has been set correctly and not to "0" (OFF)
- New plug is wired correctly if you have changed the fitted moulded plug.

If the appliance is still not operating after the above checks, please refer to the section on "How To Obtain Service".

Please ensure that above checks have been made as a charge will be made if no fault is found.

8 Guarantee Details

GUARANTEE DETAILS

What is covered?

- Repairs necessary as a result of faulty materials, defective components or manufacturing defect.
- The cost of functional replacement parts, but excluding consumable items.
- The labour costs of a **LAMONA** approved repairer to carry out the repair.

What is not covered?

- Transit, delivery or accidental damage or misuse and abuse.
- Cabinet or appearance parts, including knobs, flaps, handles or container lids.
- Accessories or consumable items including but not limited to, ice trays, scrapers, cutlery baskets, filters and light bulbs.
- Repairs required as a result of unauthorised repair or inexperienced installation that fails to meet the requirements contained in the user instruction book.
- Repairs to products used on commercial or non-residential household premises.
- Loss of frozen food in freezers or fridge/freezers. (Food loss insurance is often included within your household contents insurance policy, or may be available separately from your retailer).

Important notes.

- Your **LAMONA** product is designed and built for domestic household use only.
- The guarantee will be void if the product is installed or used in commercial or non-residential domestic household premises.
- The product must be correctly installed, located and operated in accordance with the instructions contained in the User Instructions Booklet provided.
- The guarantee is given only within the boundaries of the United Kingdom.
- The guarantee is applicable only to new products and is not transferable if the product is resold.
- **LAMONA** declines any liability for incidental or consequential damages. The guarantee does not in anyway diminish your statutory or legal rights.

YOUR GUARANTEE

Product Guarantee Details (UK only)

Your appliance has the benefit of a comprehensive manufacturer's guarantee which covers the cost of breakdown repairs. (Details of which are shown on your Proof of Purchase Document).

- Any claim during the period of the guarantee (MUST BE ACCOMPANIED BY THE PROOF OF PURCHASE)
- The product must be correctly installed and operated in accordance with the manufacturer's instructions and used for normal domestic purposes.
- This guarantee does not cover accidental damage, misuse or alterations which are likely to affect the product.
- The guarantee is invalid if the product is tampered with, or repaired by any unauthorised person.

(The guarantee in no way affects your statutory or legal rights)

What to do if you need to report a problem-

Please ensure you have ready:

- The product's model & serial numbers
- Howdens Proof of Purchase document
- Your full contact details.

Call the Lamona Service Line on 0845 00 60 006

**BU SAYFA FTP_AKÜ ENERJİ ADRESİNDEN
MATBAA TARAFINDAN ALINARAK BASILACAKTIR.**

BU SAYFAYA FTP_AKÜ TIPETİKETİ
ADRESİNDEN MATBAA
TARAFINDAN ALINARAK
BASILACAKTIR.