

# LOGIK

## 4 Burner Gas Hob

Instruction / Installation Manual  
LGHOBX12

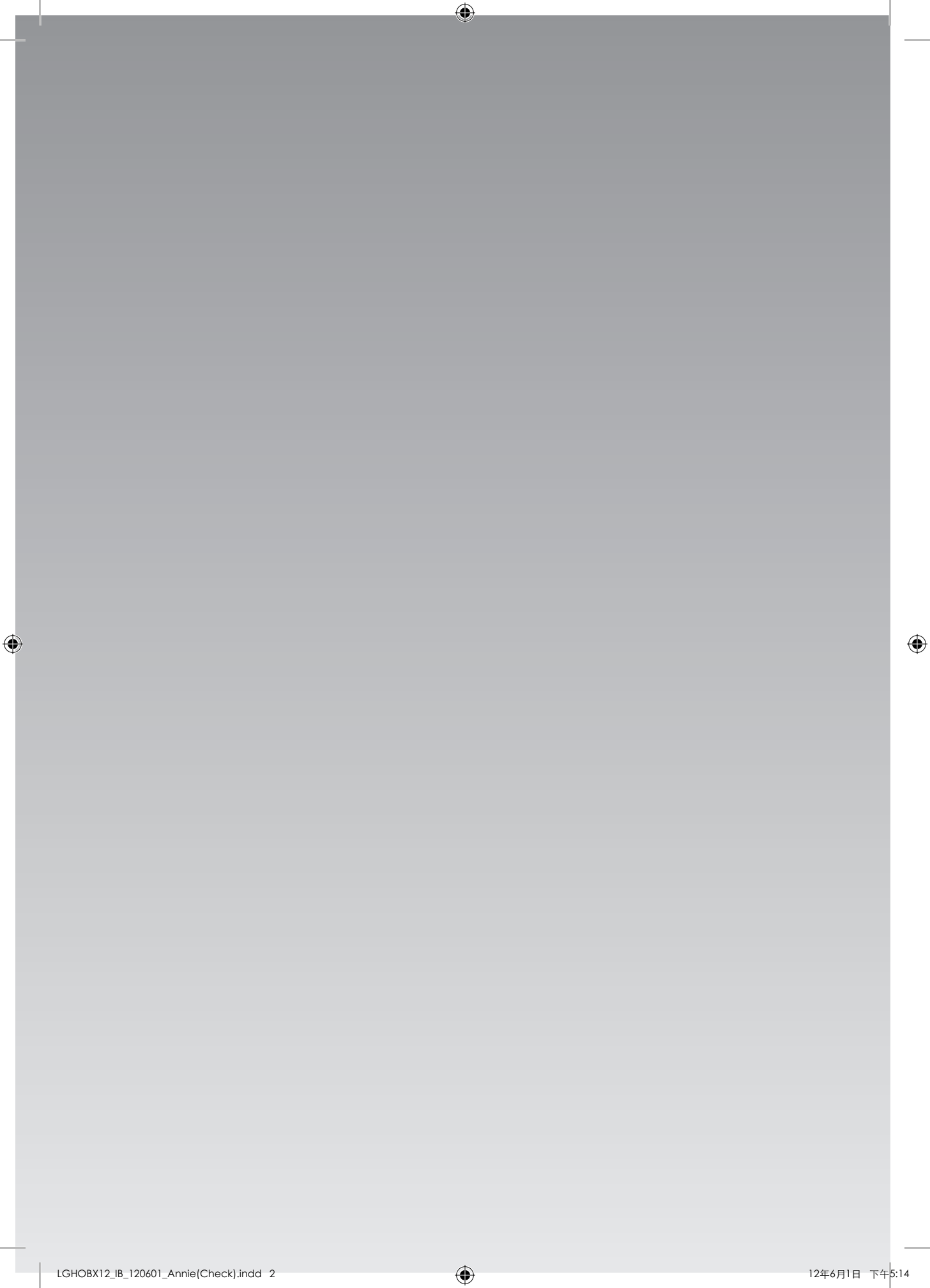



# Contents

<b>Unpacking</b> .....	<b>4</b>
<b>Product Overview</b> .....	<b>5</b>
The Main Unit.....	5
Control Panel.....	5
<b>Before Using Your New Hob</b> .....	<b>6</b>
<b>Lighting the Hob</b> .....	<b>6</b>
<b>Flame Failure Safety Feature</b> .....	<b>7</b>
<b>If the Burner Does Not Light</b> .....	<b>7</b>
<b>If the Flame is Irregular</b> .....	<b>7</b>
<b>Electricity Failure</b> .....	<b>7</b>
<b>Cookware Guidelines</b> .....	<b>8</b>
<b>Cleaning and Maintenance</b> .....	<b>9</b>
<b>Cleaning the Gas Hob</b> .....	<b>9</b>
<b>Burner Parts and Pan Supports</b> .....	<b>10</b>
<b>Replacing the Burners</b> .....	<b>10</b>
<b>Hob Controls</b> .....	<b>10</b>
<b>Hints and Tips</b> .....	<b>11</b>
<b>Specifications</b> .....	<b>12</b>
<b>Burner Values</b> .....	<b>12</b>
<b>Installation</b> .....	<b>13</b>
<b>Wiring</b> .....	<b>13</b>
<b>Ventilation Requirements</b> .....	<b>14</b>
<b>Gas Installation</b> .....	<b>14</b>
<b>Installation and Service Regulations</b> .....	<b>14</b>
<b>Location</b> .....	<b>15</b>
<b>When the Hob is First Installed</b> .....	<b>16</b>
<b>Gas Connection</b> .....	<b>16</b>
<b>Cut Out Dimensions</b> .....	<b>17</b>
Product Overall Dimensions.....	17
<b>Fitting the Hob into the Worktop</b> .....	<b>17</b>
Check the Hob After Installation & Before Using .....	17
Pressure Testing .....	17
<b>Conversion from NG to LPG or from LPG to NG</b> .....	<b>18</b>
Natural Gas.....	18
LP Gas .....	18
Method.....	18
<b>To Adjust the Gas Rate</b> .....	<b>18</b>
<b>Minimum Setting or Turn Down</b> .....	<b>19</b>
<b>Burner Configuration</b> .....	<b>19</b>
<b>Safety Warnings</b> .....	<b>20</b>

**Thank you** on the purchase of your new Logik 4 Burner Gas Hob.

You must read this manual in order to fully understand how to operate it correctly.

This unit **MUST** be installed by a competent and registered engineer (Gas Safe in the UK).

Please allow the installer to view the installation section of this manual.

Read all the safety warnings carefully before use and keep this manual for future reference.

## Unpacking

Remove all packaging from the unit. Retain the packaging. If you dispose of it please do so according to local regulations.

The following items are included:

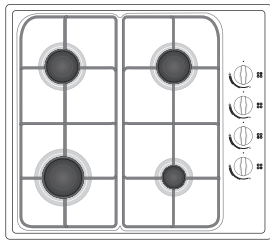

Main Unit

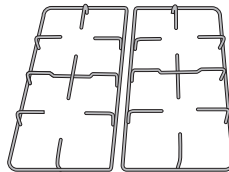

Pan Support (Left/Right) × 2  
P.N.: 37016688 (Left/Right)



Fixing Plate × 4  
P.N.: 37001970

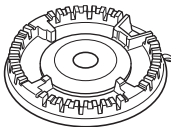

100 mm Burner Ring × 1  
P.N.: 37001476

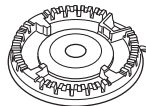

75 mm Burner Ring × 2  
P.N.: 37001477

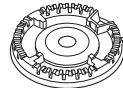

55 mm Burner Ring × 1  
P.N.: 37001478



Seal × 1  
P.N.: 62000705



100 mm Burner Cap × 1  
P.N.: 37001479



75 mm Burner Cap × 2  
P.N.: 37001480



55 mm Burner Cap × 1  
P.N.: 37001481



Screw × 4  
P.N.: 37002652



Instruction / Installation  
Manual  
P.N.: 52068804

### LPG Conversion Kit:



LPG Nozzle × 4  
P.N.: Ø 85 37016927  
Ø 65 37001483  
Ø 50 37001484

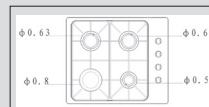

LPG Nozzle Installation Guide × 1  
P.N.: 52007667



LPG Replacement Rating  
Plate Sticker × 1  
P.N.: 20628175



If items are missing or damaged please contact Partmaster (UK only).  
Tel: 0844 800 3456 for assistance.

\* All images are for indication only; please refer to your individual unit for actual item.

# Product Overview

## The Main Unit

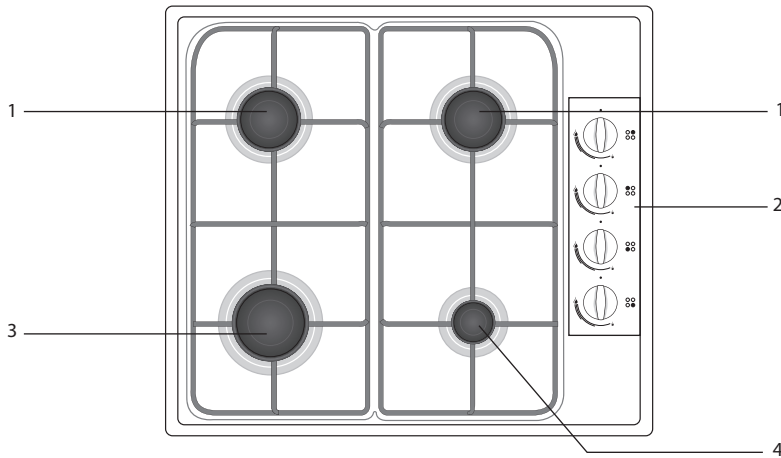

1. Standard Burner (75 mm)
2. Control Panel
3. Large Burner (100 mm)
4. Small Burner (55 mm)

## Control Panel

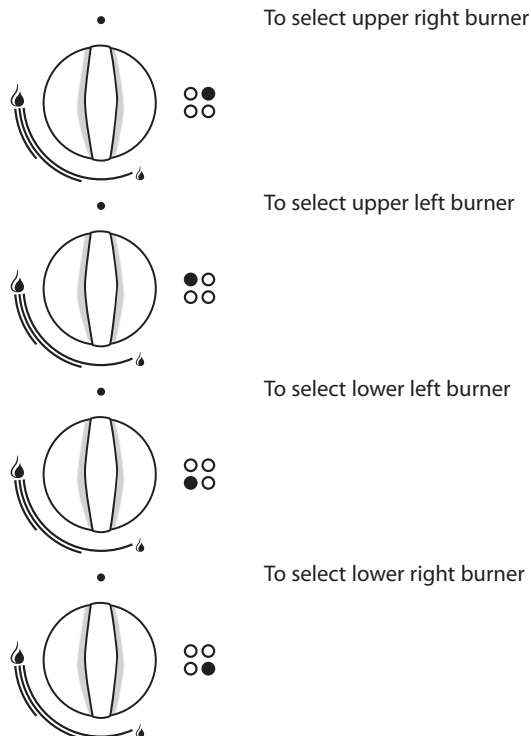

\* All images are for indication only; please refer to your individual unit for actual item.

## Before Using Your New Hob

Before using your new hob, please:

- Read this manual fully taking special note of the 'Safety Warnings' section.
- Plug the hob into the electricity supply and turn it on so that the ignition circuit will work.



This appliance is for cooking purposes only. It must not be used for other purposes, e.g. room heating.

## Lighting the Hob

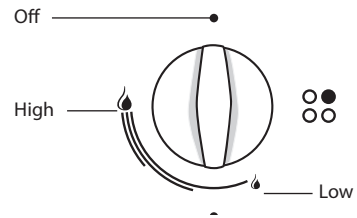

1. Choose the control for the burner you want to use.
2. Press and hold the Burner control in and then turn it anti-clockwise to the large flame symbol . The spark ignition will operate whilst you hold in the control.

Continue to hold the control in for approximately 10 seconds after the burner has lit. Releasing the control too soon will extinguish the flame due to the flame failure safety feature.



### Manual Ignition (in case of electricity failure)

To ignite one of the burners, press and turn the control counter-clockwise so that the control is at the  position. Hold an ignition source (e.g. candle lighter) close to the upper circumference of the burner. Move the ignition source away as soon as you see a stable flame. Continue holding the control in for approximately 10 seconds after the burner has lit. Releasing the control too soon will extinguish the flame due to the flame failure safety feature.

3. Adjust the flame anywhere between the  and  positions. Do not adjust the flame between the  and Off position.
4. After ignition, check the flames visually. If you see yellow tipped, lifted or unstable flames; turn the control off, and check the assembly of the burner rings and caps. Allow these to cool before touching. Also, make sure that no liquid has entered into the burner cups. If the burner flames go out accidentally, turn the burners off, and do not try to light them again for at least 90 seconds (to allow the gas to disperse).
5. When turning the hob off, turn the control in a clockwise direction. If the control stops at the maximum flame mark, push the control in slightly and continue turning clockwise to the off mark, 'O'.



- If the burner does not light within 15 seconds, turn the control off and wait for at least 90 seconds before trying again.
- To switch the burner off, turn the control clockwise to the off position.
- After use, always turn the controls to the off position.



- This appliance is for cooking purposes only. It must not be used for other purposes, for example room heating.
- The use of a gas cooking appliance results in the production of heat, moisture and products of combustion in the room in which it is installed. Ensure that the kitchen is well ventilated especially when the appliance is in use: keep natural ventilation holes open or install a mechanical ventilation device (mechanical extractor hood). Prolonged intensive use of the appliance may call for additional ventilation, e.g. opening of a window, or more effective ventilation, e.g. increasing the level of mechanical ventilation where present.

\* All images are for indication only; please refer to your individual unit for actual item.

## Flame Failure Safety Feature

The flame supervision device (FSD) probe cuts off the gas supply to the burner if the flame is extinguished. When lighting the burner, hold down the control for approximately 5 – 10 seconds after the burner has lit. Releasing the control too soon will extinguish the flame.

If the flames are accidentally extinguished, turn off the burner and do not try to light it again for at least 90 seconds (to allow the gas to disperse).

## If the Burner Does Not Light

If the burner does not light, check that:

- The hob is connected to the electrical supply and the supply is switched on.
- The gas is turned on.
- You have held down the control for at least 5 – 10 seconds after the flame has been lit.
- The ignitors are sparking. If the ignitors are not sparking, they may be dirty or wet. Clean them gently with a small nylon brush such as a toothbrush as shown below. Ensure the electrical supply has been disconnected before cleaning.



To avoid damage to the ignition circuit NEVER light the hob when the burners are not in place.

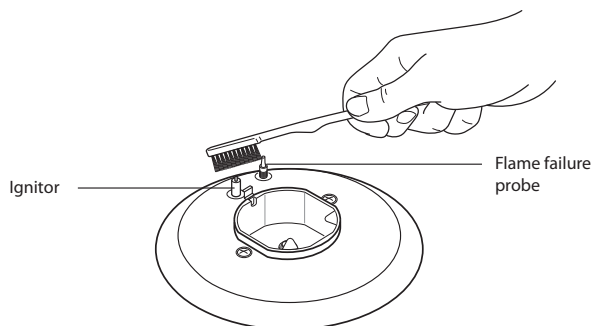

## If the Flame is Irregular

If the flame is yellow or irregular, check that the burner parts, including the burner cap (allow to cool before touching), are:

- Clean and dry.
- Positioned correctly. See 'Replacing the Burners'.
- Also see 'Hints and Tips'.

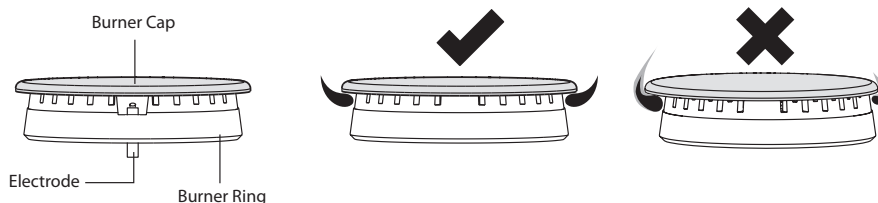

## Electricity Failure

If there is an electricity failure, you can still use your hob. Light the burners by holding an ignition source (e.g. candle lighter) close to the side of the burner and turning the control to the High position to light the gas. The controls must still be held down for 5 – 10 seconds after the burner has lit. Releasing the controls too soon will extinguish the flame. Adjust the controls as required.

\* All images are for indication only; please refer to your individual unit for actual item.

## Cookware Guidelines

To get the best out of your hob, follow these simple suggestions:

- Use saucepans with thick flat bottoms. Food in a saucepan with an uneven bottom will take longer to cook.

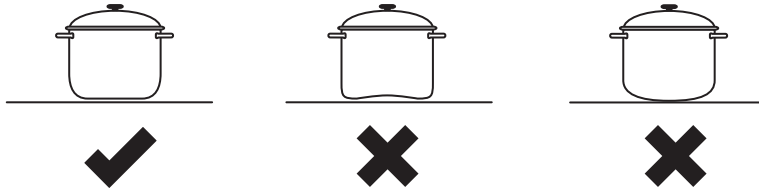

- Do not use large saucepans or frying pans that overlap the edges of your hob as this can deflect heat onto your worktop and damage the surface, and may also cause a hazard.
- Always make sure saucepans are stable. Using very heavy saucepans may bend the trivet/pan support or deflect the flame.
- Always lift the cookware when removing from the hob, do not drag.
- When you need to boil, simmer or fry food, first set the temperature to the High position. Once the food is boiling, reduce the temperature to maintain a steady heat to cook your food thoroughly. Doing this will reduce the cooking time and save energy.
- Pan sizes should be as per the table shown below.

Burners	Minimum Diameter	Maximum Diameter
Large (100mm)	22 cm	26 cm
Standard (75mm)	14 cm	22 cm
Small (55 mm)	12 cm	18 cm

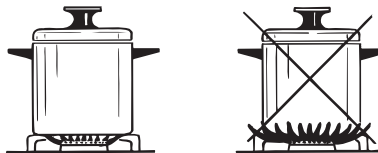

Do not use cooking vessels on the hob that overlap its edges.

- Using a lid will reduce cooking times and save energy.
- When liquid comes to a boil, reduce the temperature setting to maintain the desired level of boiling.
- Choose cookware of the proper size, material and construction.
- Minimise the amount of liquid or fat to reduce cooking times.
- Select the proper temperature setting for the cooking task.

\* All images are for indication only; please refer to your individual unit for actual item.



## Cleaning and Maintenance



Steam Cleaners must not be used to clean this product.



To avoid shock hazard, always disconnect the hob from the electrical supply.

Cooking Part	Cleaning	Important
Trivets/pan supports, burner caps and enamel surfaces	<ul style="list-style-type: none"> <li>Hot soapy water and nylon scourer.</li> <li>Mild abrasive cream cleaners.</li> <li>Fume-free or heavy-duty oven cleaners (follow manufacturer's instructions).</li> </ul>	<ul style="list-style-type: none"> <li>Always allow hob parts to cool completely before cleaning them.</li> <li>Always apply minimal pressure with abrasive cleaners.</li> <li>Remove spills as soon as the hob is cool to avoid the spills becoming burnt on.</li> </ul>
Burner parts	<ul style="list-style-type: none"> <li>Hot soapy water.</li> <li>To clear the holes use a stiff nylon brush.</li> <li>Mild abrasive cream cleaners.</li> </ul>	<ul style="list-style-type: none"> <li>Ensure burner parts are dry before refitting.</li> <li>Reassemble the burner parts correctly.</li> </ul>
Controls	<ul style="list-style-type: none"> <li>Hot soapy water and a soft cloth.</li> </ul>	<ul style="list-style-type: none"> <li>Care must be taken if removing the controls from the shafts.</li> <li>If cleaning the controls whilst they are attached to the shaft, ensure liquid does not enter the appliance.</li> </ul>
Hob surfaces	<ul style="list-style-type: none"> <li>Soak stains under a hot soapy cloth, rinse and dry thoroughly.</li> <li>Hard water spots can be removed with household white vinegar.</li> <li>Non-abrasive hob surface cleaners. Regular use of a polish designed for use with hobs will reduce fingerprints and other marks.</li> </ul>	<ul style="list-style-type: none"> <li>Never use harsh/abrasive cleaning agents as they will damage the finish.</li> <li>Chlorine or chlorine compounds in some cleaners are corrosive to hob surface and may damage the appearance of your hob. Check the label on the cleaner before using.</li> </ul>
Electrodes	<ul style="list-style-type: none"> <li>Toothbrush.</li> </ul>	<ul style="list-style-type: none"> <li>A dirty or wet electrode will prevent the burner lighting efficiently. Ensure the appliance has been disconnected from the electrical supply before cleaning or drying.</li> </ul>

## Cleaning the Gas Hob

Maintenance Period	Description
Daily	<ul style="list-style-type: none"> <li>Clean gas hob as per the instructions.</li> </ul>
Monthly	<ul style="list-style-type: none"> <li>Remove all burner parts, and clean using a non-abrasive detergent. Rinse in cold water, dry thoroughly, and replace.</li> <li>Clean the ignitor and probe carefully, using a toothbrush.</li> </ul>
Every year	<ul style="list-style-type: none"> <li>Contact your local authorized gas Service Agent to perform a thorough check on all gas components on the gas hob.</li> </ul>

## Burner Parts and Pan Supports

You can remove and clean these parts with hot soapy water or non-abrasive detergents. Clean spills regularly before they become burnt on. Do not wash these parts in a dishwasher.

After cleaning, check that the burner rings and burner caps are dry before replacing correctly.

It is very important to check that the burner rings and burner caps have been correctly positioned. Failure to do so can cause serious problems.



To avoid damage to the ignition circuit NEVER light the hob when the burners are not in place.

The surface of the burner cover will gradually lose its gloss finish with time. This is quite normal and will not effect the efficiency of the hob.

## Replacing the Burners

Check that:

- The ignitor is always clean to ensure trouble-free sparking.
- The FSD probe is always clean to ensure correct operation of the safety valves.



- Both the ignitor and probe must be very carefully cleaned using a toothbrush.
- When replacing the burner parts, ensure you do not damage the ignitor or temperature probes.

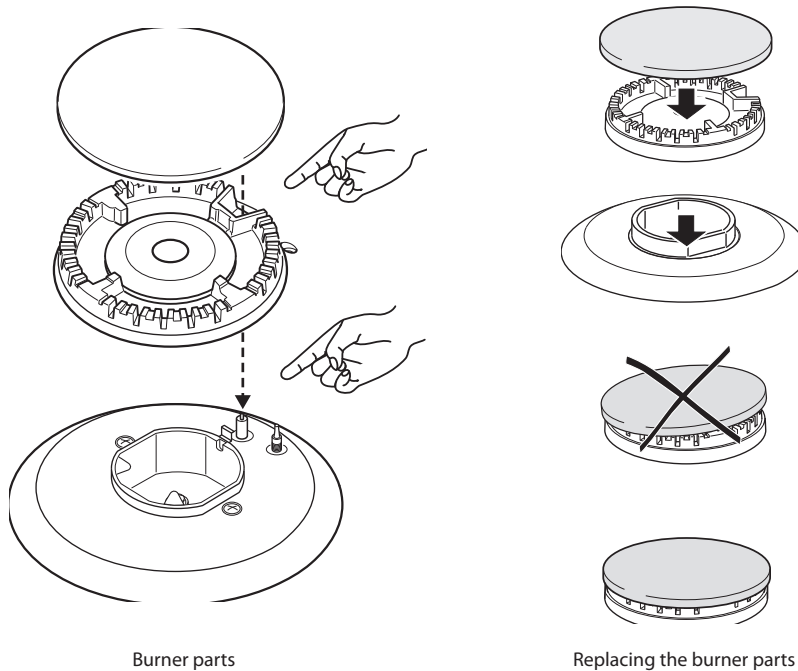

## Hob Controls

If you have problems with the hob controls (gas taps), call your Authorised Service Centre.

These parts are not user serviceable.

\* All images are for indication only; please refer to your individual unit for actual item.

## Hints and Tips

Problem	Possible Solutions
My burner does not light	<ul style="list-style-type: none"> <li>• Check the hob is plugged in and the electricity is switched on.</li> <li>• Check the gas supply valve is turned on and the gas supply to the house is working. You should hear the gas when you turn a burner on.</li> <li>• The ignitors may be dirty. Clean gently with a small nylon brush such as a toothbrush.</li> <li>• The burner parts may not be located properly. Check the assembly and make sure the burner cap is sitting flat.</li> </ul>
My burner flames are yellow or hard to start	<ul style="list-style-type: none"> <li>• The burner parts may not be located properly. Check the assembly and make sure the burner cap is sitting flat.</li> <li>• If you use bottled gas this may indicate you are getting near the end of the bottle.</li> <li>• Check the burner parts are clean and dry.</li> <li>• The gas pressure may not be at the correct level. Check with your approved service agent.</li> <li>• Your hob may not be set up for the gas you are using. Check this with your approved service agent or installer.</li> </ul>
One of my burners has an uneven flame	<ul style="list-style-type: none"> <li>• Check the burner parts are clean and dry. Check the assembly and make sure the burner cap is sitting flat.</li> </ul>
My burner goes out when I let go of the control	<ul style="list-style-type: none"> <li>• The hob has a safety feature called 'Flame Supervision Device (FSD)'. Hold down the control for approximately 5 – 10 seconds after the burner has lit. Releasing the control too soon will extinguish the flame. See the 'Flame Failure Safety Feature' section.</li> </ul>
The flame goes out at low settings	<ul style="list-style-type: none"> <li>• The gas supply pressure may be low. Check this with your approved service agent.</li> <li>• The low setting may have been adjusted incorrectly. Check this with your approved service agent.</li> </ul>
My burners do not turn down much (when running on bottled gas or LPG)	<ul style="list-style-type: none"> <li>• Your burners may not have been adjusted correctly. Check this with your approved service agent.</li> </ul>
The flame tips are very yellow	<ul style="list-style-type: none"> <li>• Call your approved service agent.</li> </ul>
There are objectionable odours	<ul style="list-style-type: none"> <li>• Call your approved service agent.</li> <li>• Ensure the hob and burners are clean and dry.</li> </ul>
The flame appears to lift off the burner	<ul style="list-style-type: none"> <li>• Call your approved service agent.</li> </ul>
There is an electricity failure	<ul style="list-style-type: none"> <li>• If there is an electricity failure, you can still use your hob. Light the burners by holding a candle lighter close to the side of the burner and turning the control to the High position. Wait until the flame is burning evenly before adjusting. The control must still be held down for 5 – 10 seconds after the burner has lit. Releasing the control too soon will extinguish the flame.</li> </ul>

## Specifications

<b>Model</b>	<b>LGHOBX12</b>
<b>Rated Voltage (V)</b>	230
<b>Rated Frequency (Hz)</b>	50
<b>Power Consumption(W)</b>	1
<b>Gas Type</b>	NG or LPG (Default set to NG)
<b>Net Weight (kg)</b>	7.5
<b>Product Dimensions (cm)</b>	
<b>External Width</b>	58
<b>External Depth</b>	51
<b>Product Dimensions (cm)</b>	
<b>Internal Width</b>	55
<b>Internal Depth</b>	48

Features and specifications are subject to change without prior notice.

## Burner Values

<b>Burner Power Output</b>	<b>LPG</b>	<b>Natural Gas</b>
	<b>G 30-30 mBar</b>	<b>G 20-20 mBar</b>
<b>Large Burner (100 mm)</b>	3 kW	3 kW
<b>Standard Burner (75 mm)</b>	1.75 kW	1.75 kW
<b>Small Burner (55 mm)</b>	1 kW	1 kW

## Installation



The hob must be installed by a Gas Safe Registered engineer in accordance with the Gas Safety (Installation and Use) Regulations and to the relevant standards. Please, ensure that, once the hob is installed, it is easily accessible for the engineer in the event of a breakdown.

- Prior to installation, ensure that the local distribution conditions (nature of gas and pressure) and the adjustment of the product are compatible. The adjustment conditions for this product are stated on the data plate.
- Ensure that there is a mains socket within reach of the hob cable (1500 mm from the rear right of the product). This must be accessible after installation or an all-pole disconnection switch must be provided in the fixed wiring in accordance with the local wiring regulations. The mains cable must not touch any metal parts.
- Ensure that your kitchen worktop is designed for use in a kitchen.
- This appliance is not connected to a combustion products evacuation device. It shall be installed and connected in accordance with current installation regulations. Particular attention shall be given to the relevant requirements regarding ventilation.

## Wiring

Should the mains lead of the appliance ever require replacing, we recommend that this be carried out by a qualified electrician who will replace it with a lead of the same size and temperature rating.



This appliance must be earthed.

The flexible mains lead is supplied connected to a BS1363 fused plug, having a fuse of 3Amp capacity. If this plug does not fit the socket in your home, it should be replaced with a suitable plug as outlined below.

The wires in the mains lead are coloured in accordance with the following code:



Green & Yellow = Earth

Blue = Neutral

Brown = Live

1. The wire which is coloured green and yellow must be connected to the terminal marked E (  $\perp$  ) Earth.
2. The wire which is coloured blue must be connected to the terminal marked N (Neutral).
3. The wire which is coloured brown must be connected to the terminal marked L (Live).
4. Ensure all screws are adequately tightened. Do not over tighten as you may risk damaging the screw threads.

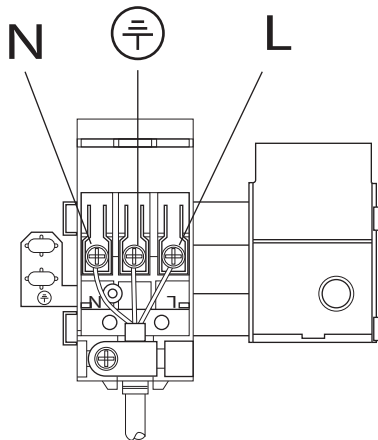

The plug and socket must be accessible after installation, or an all-pole disconnection switch provided in the fixed wiring in accordance with the local wiring regulations.

\* All images are for indication only; please refer to your individual unit for actual item.

## Ventilation Requirements

---

- This appliance is not connected to a combustion products evacuation device. It should be installed and connected in accordance with current installation regulations. Particular attention should be given to the relevant requirements regarding ventilation.
- The appliance should be installed in a room or space with an air supply in accordance with the latest edition of BS5440-2.
- For rooms with a volume of less than 5m<sup>3</sup> — permanent ventilation of 100cm<sup>2</sup> free area will be required.
- For rooms with a volume of between 5m<sup>3</sup> and 10m<sup>3</sup> a permanent ventilation of 50cm<sup>2</sup> free area will be required unless the room has a door which opens directly to the outside air in which case no permanent ventilation is required.
- For rooms with a volume greater than 10m<sup>3</sup> — no permanent ventilation is required.



- Regardless of room size, all rooms containing the appliance must have direct access to the outside air via a window that opens or equivalent.
- Where there are other fuel burning appliances in the same room, the latest edition of BS 5440-2 should be consulted to determine the correct amount of free area ventilation requirements.

## Gas Installation

---



This cooker uses and is ready to use NATURAL GAS only and cannot be used with any other gas without modification. This appliance is manufactured for conversion to LPG after fitting new injectors, new supply hose and making adjustments. Refer to “replacement of burner injectors” section for details.

## Installation and Service Regulations

---



This appliance must be installed and serviced only by a suitably qualified and Gas Safe Registered engineer, and in accordance with the current editions of the following standards and regulations or other locally applicable regulations:

Gas Safety (Installation and Use) Regulations

Building Regulations

British Standards (BS 5440, BS 6172 and BS 6891)

Regulations for Electrical Installation (BS 7671, (Latest Edition))

## Location

The hob should be located in a kitchen or kitchen/diner, but not in a bathroom, shower room, garage or a bed sitting room with a volume less than 20 cubic metres.

Before making the cut out in the worktop ensure that there is a minimum distance of 60 mm between the rear edge of the hob and the wall. If there are non-combustible materials (ceramic tiles, metal backsplash etc.) on the wall then this can be reduced to 40 mm.

A minimum distance of 150 mm must be left between the side edges of the hob and any adjacent cabinets or walls. If there are non-combustible materials (ceramic tiles, metal backsplash etc.) on the wall then this can be reduced to 50 mm.

The minimum distance combustible material can be fitted above the hob in line with the edges of the hob is 400 mm.

The minimum distance combustible material can be fitted directly above the hob is 650 mm with a cooker hood above and 750 mm without a cooker hood above.



The use of a gas cooking appliance results in the production of heat, moisture and products of combustion in the room in which it is installed. Ensure that the kitchen is well ventilated especially when the appliance is in use: keep natural ventilation holes open or install a mechanical ventilation device (mechanical extractor hood). Prolonged intensive use of the appliance may call for additional ventilation, e.g. opening of a window, or more effective ventilation, e.g. increasing the level of mechanical ventilation where present.

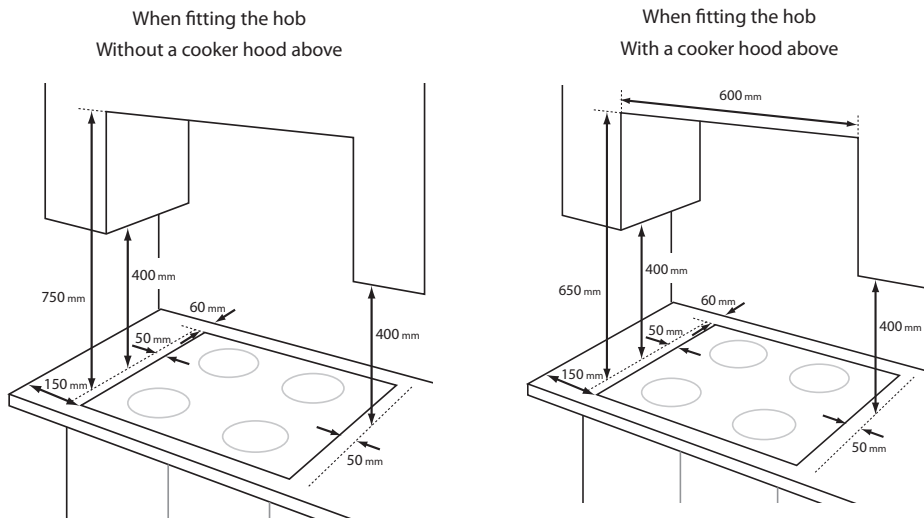

\* All images are for indication only; please refer to your individual unit for actual item.

## When the Hob is First Installed

Once the hob has been installed, it is important to remove any protective materials, which were put on in the factory.

Any gas installation must be carried out by a Gas Safe Registered engineer.

The manufacturer will not accept liability, should the above instructions or any of the other safety instructions incorporated in this manual are ignored.

The end of the manifold includes a Rc 1/2 and Rp 1/2 threaded elbow. The elbow has an arrow sign to show the direction of gas flow. If the elbow is disassembled for any reason, the arrow direction must be respected during re-assembly. The arrow head should point towards the appliance. There is a washer fitted between these components, if any adjustments are made ensure parts are screwed together without using excessive force.

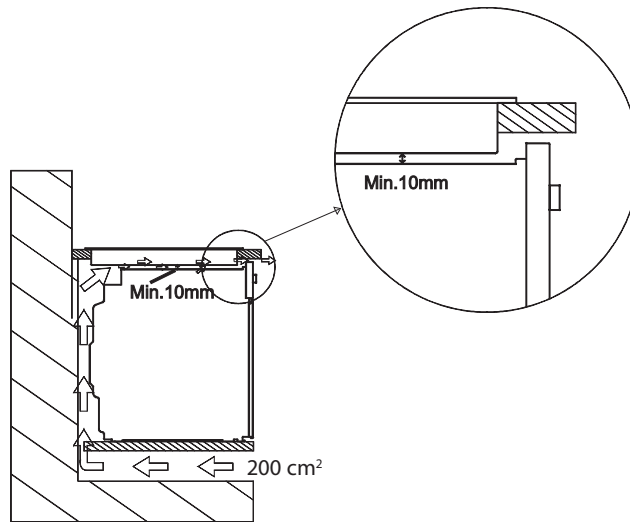

If the hob is going to be installed on the top of a built in oven without forced cooling ventilation, proper air vents must be installed to guarantee adequate ventilation, with the lower air entering with a cross section of at least 200 cm<sup>2</sup>, and the higher air exiting with a cross section of at least 60 cm<sup>2</sup>.

## Gas Connection

Connection to the gas supply should be with either rigid or semi-rigid pipe, i.e. steel or copper. The connection should be suitable for connecting to 1/2 BSP male thread. When the final connection has been made, it is essential that a thorough leak test is carried out on the hob and installation. Ensure that the main connection pipe does not exert any strain on the hob.

It is important to install the elbow correctly, with the shoulder on the end of the thread, fitted to the hob connecting pipe. Failure to ensure the correct assembly will cause leakage of gas.

- 1: End of manifold with 1/2 BSP male thread
- 2: 90 degree connection elbow
- 3: Washer

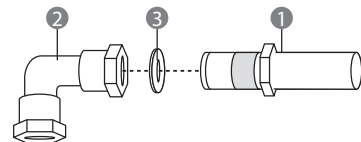

\* All images are for indication only; please refer to your individual unit for actual item.



## Cut Out Dimensions

The dimensions of the cut-out are given in the diagram.

Width: 560mm Depth: 490mm



All measurements given in millimetres (mm) and cutout dimensions are given as: 'nominal measurement'

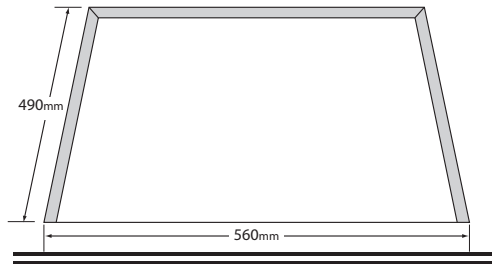

## Product Overall Dimensions

Width: 580mm Depth: 510mm

## Fitting the Hob into the Worktop

- Apply the adhesive sealing material "C" all the way round the aperture on the worktop to match the outer perimeter edge of the appliance. Ensure that the junctions overlap at the corners and no gap is left along the sealing material.
- Insert the appliance into the aperture and fix in position using the brackets and screws. Adjust the position of the brackets depending on the thickness of the worktop as indicated below and tighten the screws evenly.

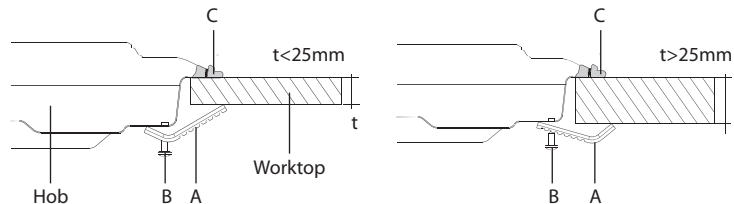

- Carefully trim away the excess sealing material "C" from around the appliance.



- If the appliance is to be installed above a cupboard or drawer it is absolutely essential that you place a separating board between the base of the appliance and the drawer unit.
- This must be fixed in place 60 mm below the hob to prevent accidental contact with the bottom of the hob which may be hot.

## Check the Hob After Installation & Before Using

When the hob has been fully installed it will be necessary to check the minimum flame setting. To do this, follow the step below,

- Turn the gas tap to the MAX position and ignite
- Set the gas tap to the MIN flame position then turn the control from MIN to MAX several times. If the flame is unstable or is extinguished follow the procedure below.

## Pressure Testing

1. Remove the left hand pan support and front left burner cap and crown.
2. Fit manometer tube over the injector.
3. Turn on the burner gas supply and ignite all the other burners.
4. Turn off the burner supplies.

\* All images are for indication only; please refer to your individual unit for actual item.

## Conversion from NG to LPG or from LPG to NG



The replacement / conversion of the gas hob should only be undertaken by Gas Safe Registered Engineer. The hob is supplied for use with Natural Gas only and cannot be used on any other gas without modification. It can be converted from NG to LPG or LPG to NG providing the correct injectors are fitted and the gas rate is adjusted to suit.

### Natural Gas

- In the United Kingdom flexible connections must not be used for built in product, rigid or semi-rigid pipework must be used.

### LP Gas

- In the United Kingdom flexible type hoses must not be used for built in products, rigid or semi-rigid pipework must be used. Ensure it is suitable for use on LP Gas up to 50mbar pressure rise.
- In all other countries this appliance must be installed in accordance with local regulations and standards.

### Method

1. Ensure that the gas taps are in the “●” position
2. Isolate the hob from the electrical supply
3. Remove all pan supports, burner caps, rings, crowns and controls.
4. With the aid of a 7mm box spanner the burner injectors can then be unscrewed and replaced by the appropriate injectors. See the Burner configuration Table for details.  
Note the size of the injector being removed to ensure the corresponding size of the new injector is used, NG vs LPG.

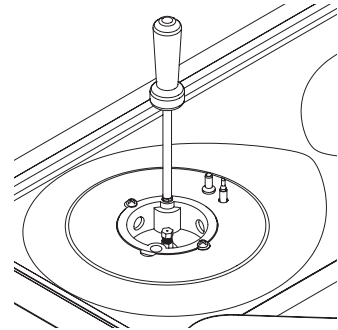

## To Adjust the Gas Rate

With the aid of a thin bladed screwdriver completely tighten down the bypass adjustment screw, which is located down the centre of the gas tap control shaft or on the gas tap body. See further adjustments in the next section.

Upon completion stick the replacement rating plate sticker on the under side of the hob.

\* All images are for indication only; please refer to your individual unit for actual item.

## Minimum Setting or Turn Down

This unit has been set at the factory for NG but can be checked after the correct pressure has been reached.

To adjust the minimum setting you will need a Ø 2.5mm x 45mm screwdriver.

1. Ignite the burner and set the control to its minimum position.

2. Remove the control.

3. **FOR NG (G20 G25)**

Rotate the turn down screw slowly until a minimum regular flame is achieved. (The flame will diminish when the screw is turned clockwise and increase when turned anti-clockwise.

**FOR LP Gas (G30 G31)**

Rotate the turn down screw clockwise until it comes to a stop, this is the fixed turn down position for LP Gas.

4. Replace the control.

5. When the setting is right check regulation by quickly rotating the control from the maximum to the minimum delivery position. The flame must not go out and remain stable throughout the range.

## Burner Configuration

Gas Category	LPG (Supplied in accessory pack)	NG (Fitted on unit)
	G30	G20
<b>GB: II<sub>2H</sub>/3 +</b>	28 – 30/37 mbar	20 mbar
<b>Large Burner (Front Left)</b>		
Injector dia. (mm)	85	115
Nominal Rating (kw)	3	3
Consumption in 1 h (at 15°C and 1013 mbar press)	218.1 gr/h	285.7 lt/h
<b>Small Burner (Front Right)</b>		
Injector dia. (mm)	50	72
Nominal Rating (kw)	1	1
Consumption in 1 h (at 15°C and 1013 mbar press)	72.7 gr/h	95.2 lt/h
<b>Medium Burner (Rear Left And Right)</b>		
Injector dia. (mm)	65	97
Nominal Rating (kw)	1.75	1.75
Consumption in 1 h (at 15°C and 1013 mbar press)	127.2 gr/h	166.7 lt/h

# Safety Warnings

## Important!

- Please make this information available to the person responsible for installing the product.
- Read these instructions carefully before installing or using this product.
- This product is for domestic / household use only.

## Installation

- This appliance shall be installed in accordance with the regulations in force and only used in a well ventilated space. Read the instructions before installing or using this appliance.
- The adjustment conditions for this product are stated on the data plate.
- This product is not connected to a combustion products evacuation device. It shall be installed and connected in accordance with current installation regulations.
- Particular attention shall be given to the relevant requirements regarding ventilation.

## Caution!

- In order to avoid hazard this unit must be installed according to these instructions.
- Please follow installation information carefully. If in doubt consult your local building regulations, local gas authority standards and electrical regulations.
- In your own interest and that of safety, it is law that all gas appliances be installed by competent persons. (Gas Safe registered installers in the United Kingdom) who undertake to work to safe standards.
- Failure to install the product correctly could invalidate any warranty or liability claims.
- **This appliance must be installed in accordance with local regulations and standards.**
- In the United Kingdom, this hob must be installed in accordance with all relevant British Standards/ Codes of Practice, in particular the latest editions of BS5440 part 2, BS6172 and BS6891. The Gas Safety (Installation and Use) Regulations. The Relevant Building/ IEE Regulations.

## Operation and Maintenance

### Hot Surface Hazard

- This appliance becomes hot during use. Do not touch the hob components, burners, trivets/pan supports or the base when hot. Before cleaning, turn the burners off and make sure the whole hob is cool and disconnect from the electrical supply. Failure to do so could result in burns, scalds or electric shocks.

### Explosion Hazard

- Do not store flammable materials such as petrol near the hob.
- No combustible material or products should be placed on or near this product at any time.
- Do not spray aerosols in the vicinity of this product while it is in operation.
- Failure to do so may result in death or electrical shock.

### Important Safety Precautions

- **CAUTION:** This appliance is for cooking purposes only. It must not be used for other purposes, e.g. room heating.
- This appliance is not intended for use by persons (including children) with reduced physical, sensory or mental capabilities, or lack of experience and knowledge, unless they have been given supervision or instruction concerning the use of the appliance by a person responsible for their safety.
- Children should be supervised to ensure that they do not play with the appliance.
- This appliance is connected to the electrical supply by a BS 1363 mains plug. This plug provides isolation from the electricity supply. The plug must remain accessible or be connected to a socket with an all-pole disconnection switch provided in the fixed wiring and easily accessible.
- Never plug this unit in using an extension lead.
- Do not stand or place heavy objects on this appliance.
- This hob is not intended to be operated by means of an external timer or separate remote control system.

- Do not use an asbestos mat or decorative covers between the flame and the saucepan as this may cause serious damage to your hob.
- Do not place aluminium foil or plastic dishes on the hob burners.
- Do not use large saucepans or frying pans that overlap the hob as this can deflect heat onto your worktop and damage the surface.
- Do not let large saucepans, frying pans or woks push any other pans aside. This could make them unstable or deflect heat onto your worktop and damage the surface.
- Do not use a steam cleaner for cleaning this product.
- Saucepan handles may be hot to touch. Ensure saucepan handles do not overhang other gas burners that are on. Keep handles out of the reach of children.
- If the mains cable is damaged, it must only be replaced by an authorised person to avoid a hazard. Ensure that the electrical connection plug/switch is accessible after installation.
- **CAUTION:** The use of a gas cooking appliance results in the production of heat, moisture and products of combustion in the room in which it is installed. Ensure that the kitchen is well ventilated especially when the appliance is in use: keep natural ventilation holes open or install a mechanical ventilation device (mechanical extractor hood). Prolonged intensive use of the appliance may call for additional ventilation, e.g. opening of a window, or more effective ventilation, e.g. increasing the level of mechanical ventilation where present.

If you require a replacement for any of the items listed below, please quote their corresponding part numbers:

Replacement Part	Part Number
Pan Support (Left / Right)	37016688
LPG Nozzle Installation Guide	52007667
LPG Replacement Rating Plate Sticker	20628175
Fixing Plate	37001970
Screw	37002652
LPG Nozzle	Ø 85 37016927 Ø 65 37001483 Ø 50 37001484
Seal	62000705
100mm Burner Rings	37001476
75mm Burner Rings	37001477
55mm Burner Rings	37001478
100mm Burner Cap	37001479
75mm Burner Cap	37001480
55mm Burner Cap	37001481



Visit [Partmaster.co.uk](http://Partmaster.co.uk) today for the easiest way to buy electrical spares and accessories. With over 1 million spares and accessories available we can deliver direct

to your door the very next day. Visit [www.partmaster.co.uk](http://www.partmaster.co.uk) or call 0844 800 3456 (UK customers only) Calls charged at National Rate.



This symbol on the product or in the instructions means that your electrical and electronic equipment should be disposed at the end of its life separately from your household waste. There are separate collection systems for recycling in the EU.

For more information, please contact the local authority or your retailer where you purchased the product.

DSG Retail Ltd. • Maylands Avenue • Hemel Hempstead  
Herts • HP2 7TG • England

(P.N.: 52068804)

