

Part No. DOC 26 Rev. 04 January 2003

SUPPLEMENTARY INSTALLATION
and
SERVICING INSTRUCTIONS

Multi Pass Sealed System boilers

For use with Kerosine or Gas Oil

**TO BE READ IN CONJUNCTION WITH THE INSTRUCTION MANUAL
SUPPLIED WITH THE BOILER**

After installing the boiler leave these instructions with the User

**This appliance is deemed a controlled service and specific regional statutory
requirements may be applicable**



List of contents

Section	Subject	Page
1	Boiler technical information	2
2	Boiler description	4
3	Boiler installation	5
4	Filling the system	6
5	Expansion vessel pressure	6
6	Connect the power supply	6
7	Commissioning	9
8	Information for the user	10

1 Boiler technical data

Connections:	Heating flow	50/90, 70/90	22 mm copper pipe
		90/140	28 mm copper pipe
	Heating return	50/90, 70/90	2" x 1" BSP
		90/140	2" x 1¼" BSP
	Cold water mains	15 mm copper pipe	
Pressure relief valve discharge	15 mm copper pipe		
Boiler thermostat range			65°C to 85°C
Safety limit thermostat cut out temperature			111°C ± 3°C
Maximum heating system pressure (cold)			1.0 bar
Minimum heating system pressure (cold)			0.5 bar
Operating pressure of pressure relief valve			2.5 bar
Expansion vessel size			12 litres (pre-charged at 1 bar)
Maximum heating system volume			157 litres (approximately)

All other technical information is as per section 2.1 Boiler Technical Data of the Instruction manual supplied with the boiler.



1.1 Boiler dimensions

See Figs. 1 and 2

50/70 and 70/90 models

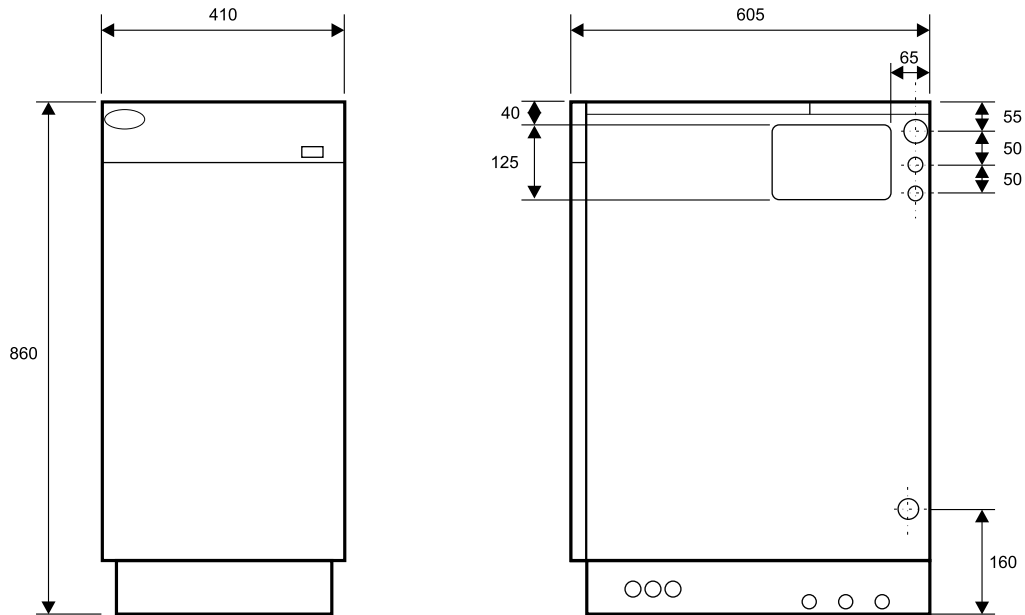

Fig. 1

90/140 model

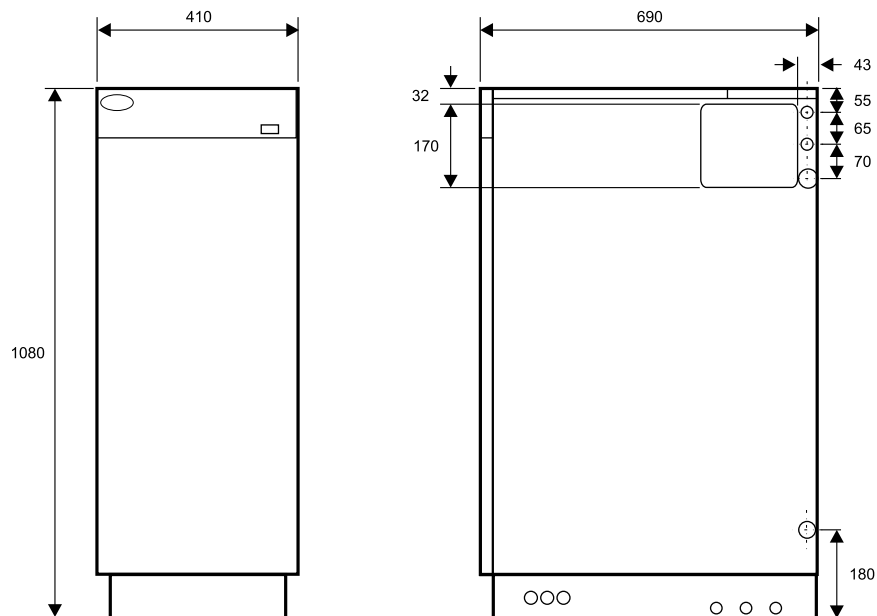

Fig. 2



GENERAL BOILER INFORMATION

2 Boiler description

The Grant MultiPass System boiler is for use on fully pumped sealed heating systems only. It is not suitable for gravity systems and should not be used with direct or 'Primatic' cylinders.

The Grant MultiPass System boiler has been designed for use with a sealed central heating system complying with the requirements of BS 5449.

All the components necessary for a sealed system are contained within the boiler casing; expansion vessel, filling loop, pressure relief valve, automatic air vent and pressure gauge.

The boiler is supplied with the burner fitted suitable for Kerosine.

The temperature of the water leaving the boiler to heat the radiators may be adjusted between 65°C and 85°C using the control thermostat.

2.1 Boiler components

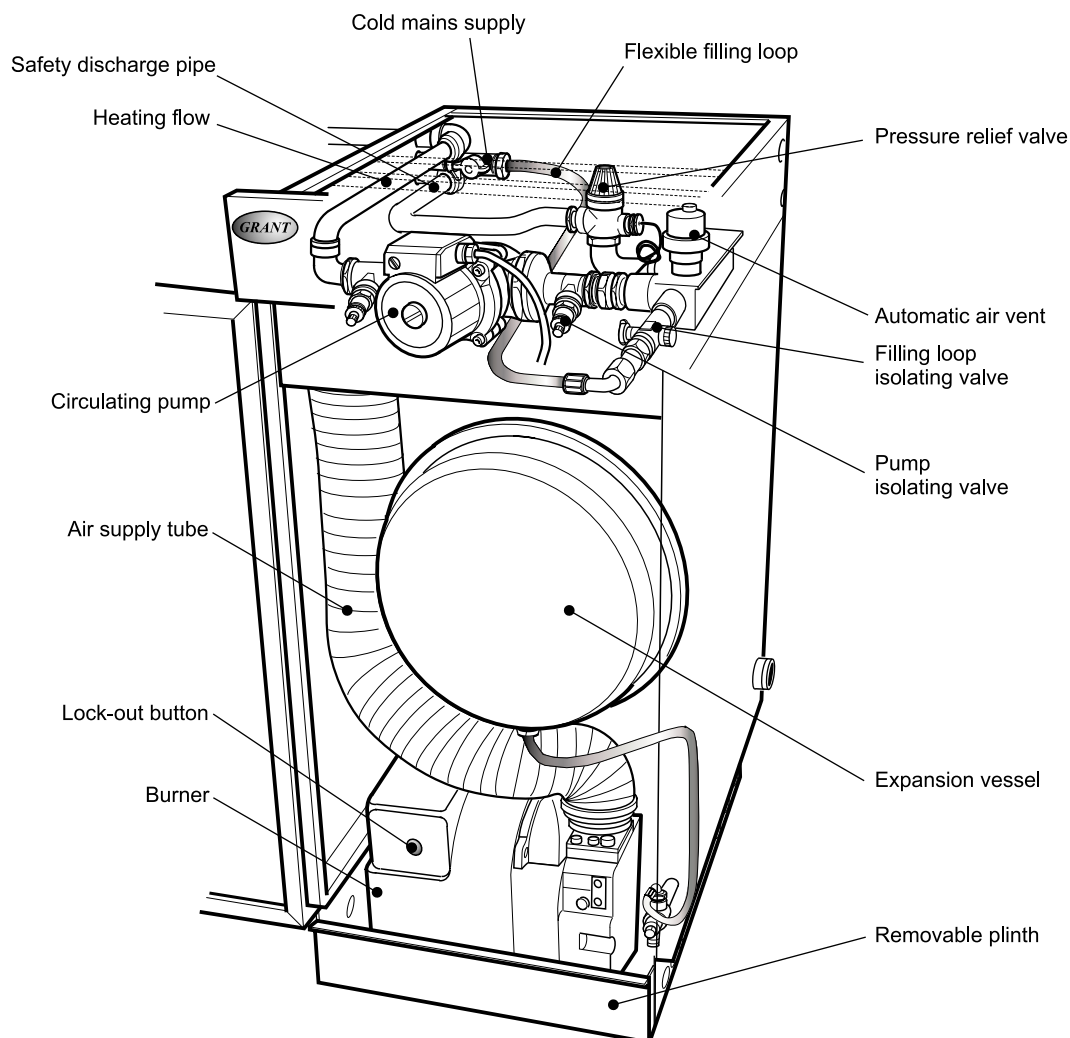

Fig. 3



3 Boiler installation

Please refer to the main instruction manual supplied with the boiler.

3.1 Water connections

- 1 A 22 mm Tectite push fit connection (50/70, 70/90) or a 28 mm connection (90/140) is provided for the heating flow. The heating flow pipe may enter the casing from either the left or the right hand side through the hole in the casing panel.
- 2 A 15 mm Tectite fitting is provided for the safety valve discharge connection. The pipework between the safety valve and the boiler must be unrestricted, i.e. no valves. The discharge pipe should be run to the outside of the building and terminate so that it cannot cause injury to persons or property.
- 3 Two 1" BSP (50/70, 70/90) or two 1¼" BSP (90/140) female tappings are provided at low level for the heating return connection.
- 4 A 15 mm Ballofix type valve is provided on a flexible filling loop hose for connection of the cold mains supply to the heating system. The cold mains supply should preferably terminate inside the boiler casing.
- 5 A drain cock is fitted to the boiler to allow the heating system to be drained.
- 6 The expansion vessel is connected via a flexible hose to allow it to be moved to gain access to the baffle cleaning cover. When replacing the vessel, care should be taken to ensure that the flexible connecting hose is not twisted.

3.2 Pipework and controls

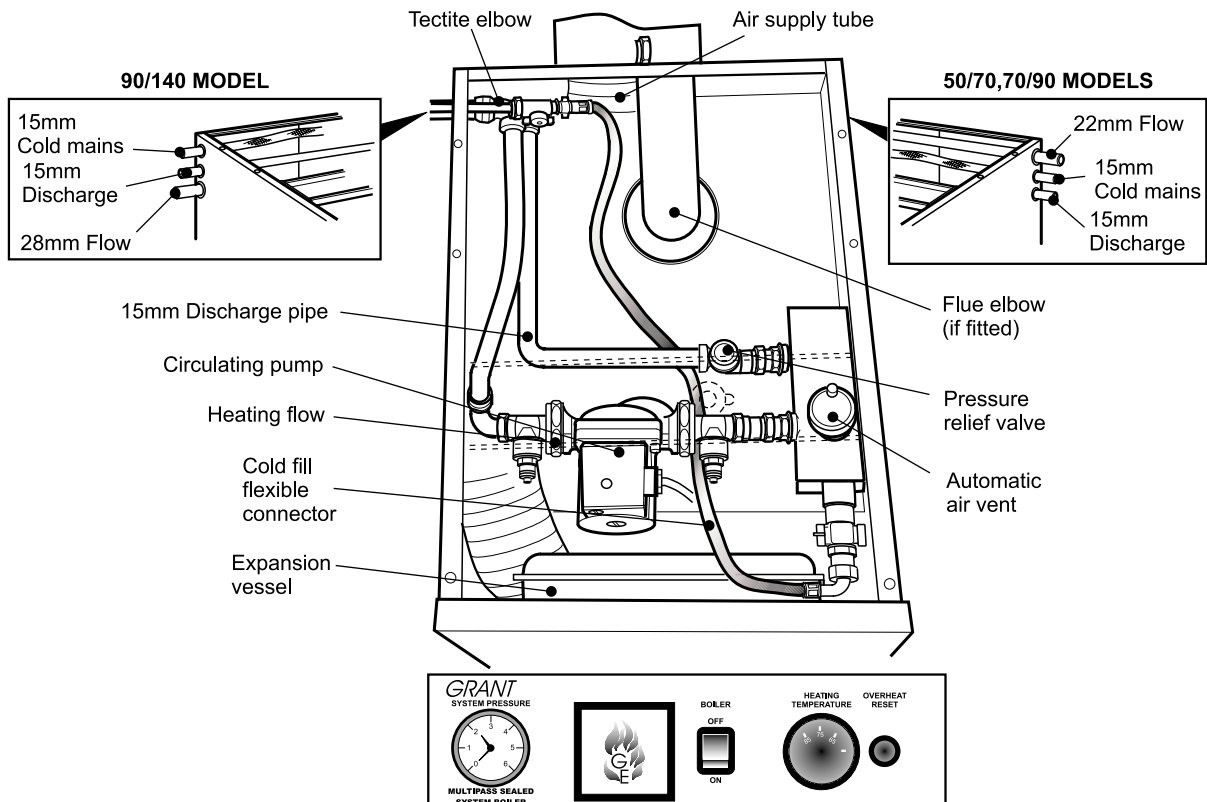

Fig. 4



4 *Filling the system*

- 1 An automatic air vent is fitted to the top of the boiler. Check that the small cap on the top of the air vent is screwed on fully, then unscrew it one complete turn - the cap remains in this position from now on.
- 2 If the flexible filling loop is used to fill the system, ensure it is connected and that the valve connecting it to the boiler is open and the valve at the front is closed.
A valve is open when the operating lever is in line with the valve, and closed when it is at right angles to it.
- 3 Ensure that the mains cold water supply valve is open (operating lever in line with the valve), then turn on the mains cold water supply and gradually open the front valve on the filling loop until water is heard to flow.
- 4 Vent each radiator in turn, starting with the lowest one in the system, to remove air.
- 5 It is important that the pump is properly vented to avoid it running dry and damaging its bearings. To gain access to the pump for venting it is necessary to remove the control panel.
Loosen the four fixing screws securing the panel to the casing, push the panel towards the rear of the boiler and lower the control panel to expose the pump.
Remove the cap, then unscrew and remove the plug from the centre of the pump. Using a suitable screwdriver rotate the exposed spindle about one turn. Replace the plug and cap.
- 6 Check the operation of the safety valve by turning the head anticlockwise until it clicks. The click is the safety valve head lifting off its seat allowing water to escape from the system.
Check that this is actually happening.
- 7 Continue to fill the system until the pressure gauge indicates 1.0 bar. Close the fill point valve and check the system for water soundness, rectifying where necessary. Water may be released from the system by manually operating the safety valve until the system design pressure is obtained.
- 8 The system design pressure (cold) should be between 0.5 bar and 1.0 bar. The pressure is equivalent to the maximum static head in bar + 0.3 (1 bar = 10.2 metres of water), where the static head is the vertical height from the centre of the expansion vessel to the highest point of the system.
- 9 Close the valves either side of the filling loop and disconnect the loop.

5 *Expansion vessel pressure*

The expansion vessel fitted is supplied with a charge pressure of 1.0 bar (equivalent to a max. static head of 10.2 metres). The charge pressure must not be less than the actual static head at the point of connection. Do not pressurise the vessel above 1.5 bar.

The air pressure in the vessel must be checked annually.

The central heating system volume, using the expansion vessel as supplied, must not exceed the recommended volumes. If the system volume is greater, an extra expansion vessel (complying with BS 4841) must be fitted as close as possible to the central heating return connection on the boiler. The charge pressure of the extra vessel must be the same as the vessel fitted in the boiler. Refer to BS 7074:1 for further guidance.

The air charge pressure may be checked using a tyre pressure gauge on the expansion vessel Schraeder valve. The vessel may be re-pressurised using a suitable pump. When checking the air pressure the water in the heating system must be cold and the system pressure reduced to zero.

A simple test to check if the expansion vessel size is adequate, is to fully heat the system and if the pressure rises no more than 2.3 bar the vessel is adequate. A higher figure indicates that an extra vessel is required.

6 *Connect the power supply*

It is recommended that the boiler should be connected to a switched mains power supply from a programmer or control system. If a Grant plug-in programmer is used, a permanent 240 V mains supply (fused at 5 Amp) must be taken to the boiler. A three core cable is required to connect the boiler terminal block to the live supply. Route the cable through one of the holes in the casing and pass it under the cable clamp and connect to the terminal block as follows:

- Live (brown) to terminal 1
- Neutral (blue) to terminal 2
- Earth (green/yellow) to terminal 4

Refer to the main instruction manual, supplied with the boiler, for electrical connection details and fitting of the optional Grant plug-in electronic programmer.

For wiring of external control systems please refer to the wiring diagrams contained in this supplement. Please contact Grant Engineering (UK) Limited for external control wiring not shown.



6.1 Boiler control panel wiring diagram

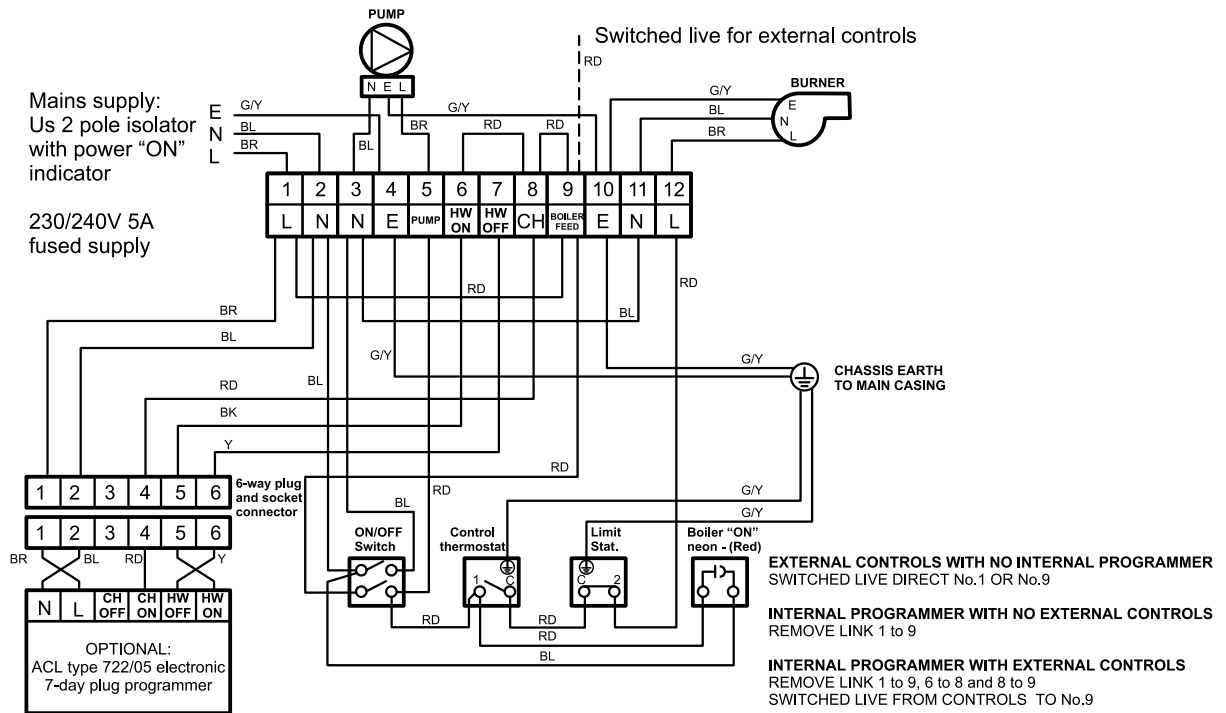

6.2 Typical control system wiring diagrams

NOTE: If using internal programmer with no external controls, remove Link 1 to 9

HONEYWELL Y PLAN WIRING DIAGRAM

HW controlled by mid position valve

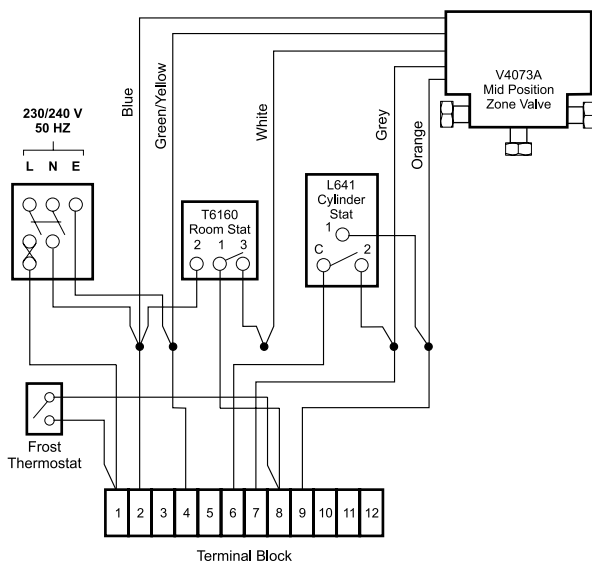

Remove links 1 to 9, 6 to 8 and 8 to 9

HONEYWELL S PLAN WIRING DIAGRAM

HW & CH controlled by two valves

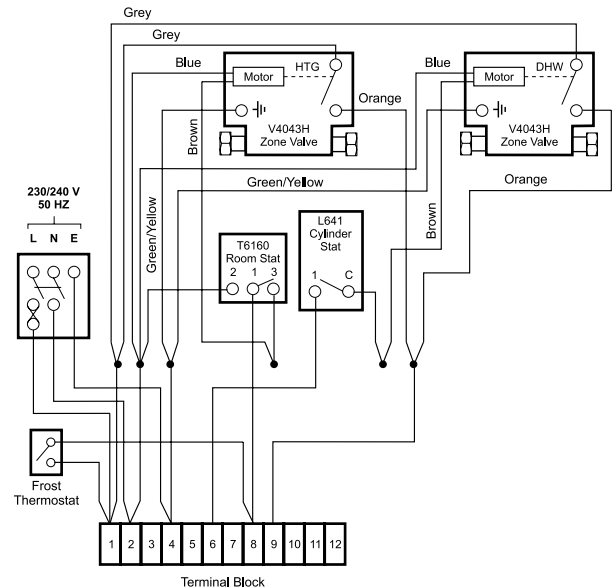

Remove links 1 to 9, 6 to 8 and 8 to 9

System models with optional programmer fitted



WIRING DIAGRAMS

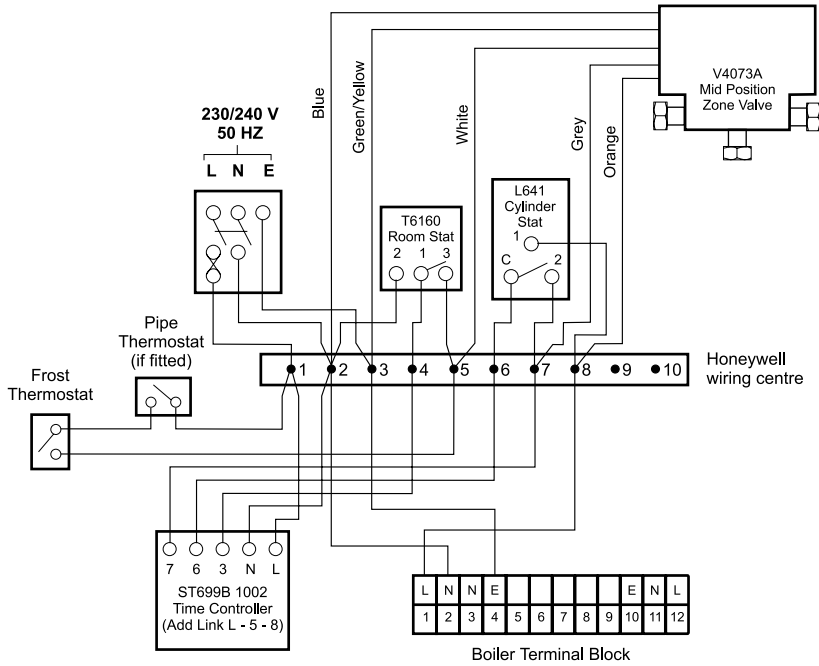

System model with Honeywell Y plan
(HW & CH controlled by mid position valve and external programmer)

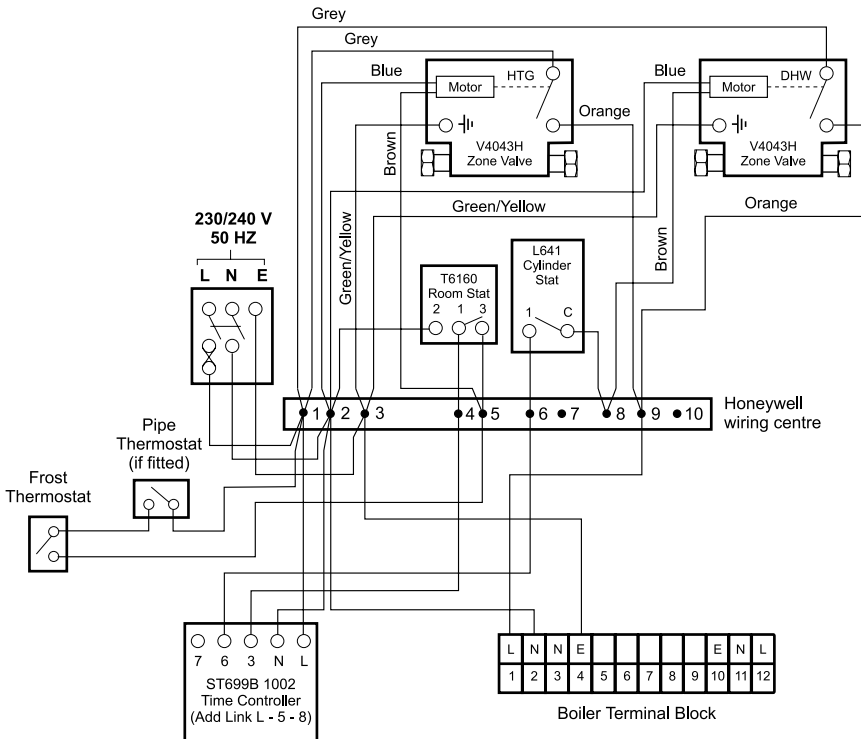

System model with Honeywell S plan
(HW & CH controlled by two valves and external programmer)



7 Commissioning

It is important that the following commissioning procedure is carried out to ensure safe and efficient operation of the boiler.

Check that the baffles are in position and that the cleaning cover is correctly fitted and a good seal made.

- 1 Check that the water system has been vented and pressurised, and there are no leaks.
- 2 Check that all fuel line valves are open.
- 3 Open the boiler casing front door and remove the burner cover.
- 4 Connect a combined vent manifold and pressure gauge connection port on the oil pump. Open the vent screw on your vent manifold to vent the supply while the pump is running.
- 5 Set the boiler On/Off switch to OFF. Check that all system controls are calling for heat and turn the boiler thermostat to maximum.
Switch on the electricity supply.
- 6 Ensure that any external controls are calling for heat. Set the boiler On/Off switch to ON. The boiler will operate and the burner should light within about 10 seconds.
If the burner does not light and the 'Lockout' reset button lights, wait for about 45 seconds then press the reset button to restart the ignition process.
This procedure may have to be repeated several times during first lighting.
- 7 With the burner alight, check the fuel pressure.
Refer to the Technical Information sections in the main instruction manual supplied with the boiler.
Adjust the pressure if necessary.
- 8 Operate the boiler until it reaches normal operating temperature. Check the oil supply/return pipe for leaks, rectifying where necessary.
- 9 With the burner alight, recheck the fuel pressure and readjust if necessary. Switch the boiler off, remove the pressure gauge and replace the plug in the pump.
- 10 Having ensured that there are no oil leaks, replace the burner cover.
- 11 Relight the boiler and allow it to run for 20 minutes then check the following:
CO₂ level, flue gas temperature and smoke number.
Refer to the Technical Information section in the main instruction manual supplied with the boiler.
- 12 A flame viewing point is provided, just above the burner. Use this to view the flame not as a test point.
- 13 Check the smoke number, if satisfactory check the CO₂ level. Adjust the burner air regulator if necessary.
- 14 Recheck the smoke number if the air damper has been moved.
- 15 Under no circumstances must the smoke number be above 1.
- 16 A suitable position for the air damper is one which gives 1% less CO₂ than that which has a smoke number of 1. It is important that the air damper is correctly set.
- 17 Check the flue gas temperature.
- 18 Check the boiler overheat thermostat by removing the boiler thermostat phial (the shorter one) from the pocket in the top of the boiler. The boiler should switch off on the overheat thermostat. Replace the phial.
Unscrew and remove the plastic cap covering the reset button, press the reset button and replace the cap.
- 19 When the boiler has been adjusted and is running satisfactorily, balance the central heating system by adjusting the radiator lock shield valves. Start with the radiator nearest the boiler and adjust the valves to achieve the required temperature drop across each radiator.
- 20 Switch off the boiler.
- 21 With the system hot, check again for leaks, rectifying where necessary.
Drain the heating system while it is hot to complete the flushing process.
- 21 Refill, vent and pressurise the system as described in section 4, adding a suitable inhibitor.
- 22 Replace the casing panels, if not already fitted.

Note: After commissioning the boiler you should complete the Commissioning Report on page 2 of the main instructions supplied with the boiler.



If the boiler is to be left in service with the User, set the controls, timer (If optional programmer is fitted, see instructions supplied in kit) and room thermostat (if fitted) to the User's requirements then refer to section 8.

If the boiler is not to be handed over immediately, close the boiler fuel supply valve and switch off the electricity supply.

If there is any possibility of the boiler being left during frost conditions, then the boiler and system should be drained.

8 *Information for the user*

The User must be advised (and demonstrated if necessary) of the following important points:-

- 1 How to light and turn off the boiler and how to operate the system controls.
- 2 The precautions necessary to prevent damage to the central heating system and to the building, in the event of the boiler not being in operation during frost conditions.
- 3 The importance of servicing the boiler to ensure safe and efficient operation. This should normally only be required once a year.
- 4 The type of fuel used.
- 5 That any servicing or replacement of parts must only be carried out by a suitably qualified engineer.
- 6 Ensure that the boiler controls and room thermostat (if fitted) are set to the User's requirements.
- 7 Tell the user the system pressure and show them the position of the safety valve discharge pipe.
- 8 Show the User how to reset the overheat thermostat and how to restart the boiler if it goes to 'Lock-out'.

Leave these instructions and the main instruction manual with the User.



SUPPLEMENT

Complies with the EC Low voltage,
Electromagnetic compatibility and
Boiler efficiency Directives



89/336/EEC
73/23/EEC
92/42/EEC

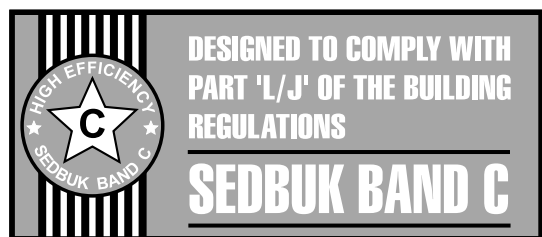

Grant Engineering (UK) Limited

Hopton House, Hopton Industrial Estate, Devizes, Wiltshire SN10 2EU
Telephone: (0870) 7775553 Fax: (0870) 7775559
email: info@grantuk.com website: www.grantuk.com

This manual is accurate at the date of printing but will be superseded and should be disregarded if specifications and/or appearances are changed in the interests of continued product improvement.

All goods sold are subject to our official Conditions of Sale, a copy of which may be obtained on application.

© Grant Engineering (UK) Limited 2003. No part of this manual may be reproduced by any means without prior written consent.

Manual compiled and designed by Publications 2000 Tel: (01670) 356211