

CERAMIC COOKER
with DOUBLE OVEN

CK 280

Instructions for use - Installation advice

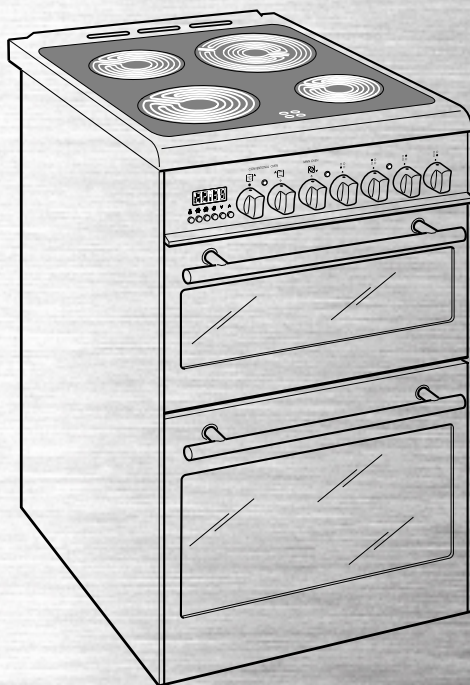

KENWOOD

CONTENTS

	Page Number
Introduction	4 - 5
Important Safeguards & Recommendations	6
Cooking Hob	7
Control Panel.	8
Use of cooking hob.	9 - 13
Top conventional electric oven.	14 - 15
Bottom main oven.	16
Cooking guide	17
Electronic programmer (Main oven only)	18 - 21
Cleaning & maintenance.	22 - 25
Advice For The Installer	26
Installation	27
Electrical section.	28 - 29
Guarantee	30
After Sales Service	31

Dear Customer,

Thank you for purchasing a Kenwood Double Oven Ceramic Cooker.

The safety precautions and recommendations in these instructions are for your own safety and that of others. They will also provide a means by which to make full use of the features offered by your appliance.

Please keep this booklet in a safe place. It may be useful in the future, either to yourself or to others in the event that doubts should arise relating to its operation.

This appliance must be used only for its intended purpose , that is for the domestic cooking of foodstuffs. Any other form of usage is to be considered as inappropriate and therefore dangerous.

The manufacturer declines all responsibility in the event of damage caused by improper, incorrect or illogical use of the appliance.

Important:

This appliance is designed and manufactured solely for the cooking of domestic (household) food and is not suitable for any non domestic application and therefore should not be used in a commercial environment.

The appliance guarantee will be void if the appliance is used within a non domestic environment i.e. a semi commercial, commercial or communal environment.

This cooker has been designed, constructed and marketed in compliance with:

- safety requirements of EEC Directive "Low voltage" 73/23;
- protection requirements of EEC Directive "EMC" 89/336;
- requirements of EEC Directive 93/68.



Read the instructions carefully before installing and using the appliance.

FIRST USE OF THE OVEN

Follow the instructions below:

- Furnish the interior of the oven by placing the wire racks as described in "Cleaning and maintenance".
- Insert shelves and tray.
- Switch the empty oven on to max to eliminate grease from the heating elements. See page 14.
- Let the oven cool down and clean the interior of the oven with a cloth soaked in water and neutral detergent, then dry carefully.

USEFUL HINTS

After removing the appliance from its packing, make sure of its integrity.

In case of doubt, please contact your supplier or a qualified engineer.

The packing materials (plastic bags, polyfoam, nails, metal strips etc.) must not be left around in easy reach of children as they may cause serious injury.

- Do not attempt to alter the technical features of the appliance as this may result in danger to the user.
- Do not carry out any cleaning or maintenance without first disconnecting the appliance from the electric supply.
- Whenever you decide to get rid of this appliance (in case of replacement with a new one), before scrapping it is recommended to render it inoperative and harmless in respect of health and antipollution regulations.

IMPORTANT SAFEGUARDS AND RECOMMENDATIONS

- **ATTENTION: please peel the plastic cover off both the sides and front of the oven before use.**
- After use, always ensure that the knobs are in the “off” position.
- Do not allow children or infirm persons to use the appliance without your supervision.
- **During and after use of the cooker, certain parts will become very hot. Do not touch hot parts.**
- **Keep children away from the cooker when it is in use.**
- Some appliances are supplied with a protective film on steel and aluminium parts. This film must be removed before using the appliance.
- Fire risk! Do not store flammable material in the oven.
- Make sure that electrical cords connecting other appliances in the proximity of the cooker cannot come into contact with the hob or become entrapped in the oven door.
- Do not line the oven walls with aluminium foil. Do not place baking trays or the drip tray on the base of the oven chamber.
- Do not allow heavy or sharp objects to drop on the glass ceramic hob. If the hob is cracked or otherwise damaged by falling objects etc., disconnect the electrical power cord and call the after-sales service.
- Do not scratch the hob with sharp objects. Don't use the hob as a work surface.
- **Do not use a steam cleaner because the moisture can get into the appliance thus making it unsafe.**
- The manufacturer declines all liability for injury to persons or damage to property caused by incorrect or improper use of the appliance.
- The various components of the appliance are recyclable. Dispose of them in accordance with the regulations in force in your country. If the appliance is to be scrapped, cut off the power cord.
- Always use oven gloves when removing the shelves and food trays from the oven whilst hot.
- Do not hang towels, dishcloths or other items on the cooker or its handle - as this could be a fire hazard.
- Clean the oven regularly and do not allow fat or oils to build up in the oven base or trays. Remove spillages as soon as they occur.
- Do not stand on the cooker or on the open oven door.
- Always stand back from the cooker when opening the oven door to allow steam and hot air to escape before removing the food.

1 - COOKING HOB

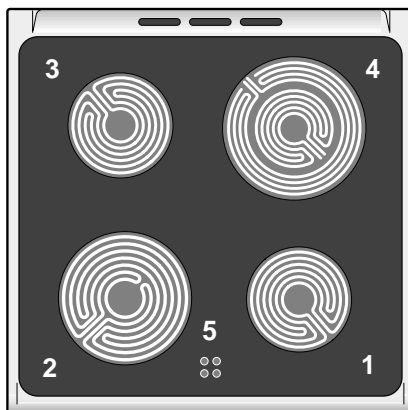

Fig. 1.1

VITROCERAMIC COOKING HOB

- | | | |
|--|-----------|------------|
| 1. 3 circuits cooking zone | Ø 145 | 1200 W |
| 2. 3 circuits cooking zone | Ø 180 | 1700 W |
| 3. 3 circuits cooking zone | Ø 145 | 1200 W |
| 4. Double cooking zone | Ø 210/120 | 2100/700 W |
| 5. Cooking zone residual heat indicators | | |

Attention: Disconnect the appliance from the mains if the ceramic hob is cracked.

2 - CONTROL PANEL

Fig. 2.1

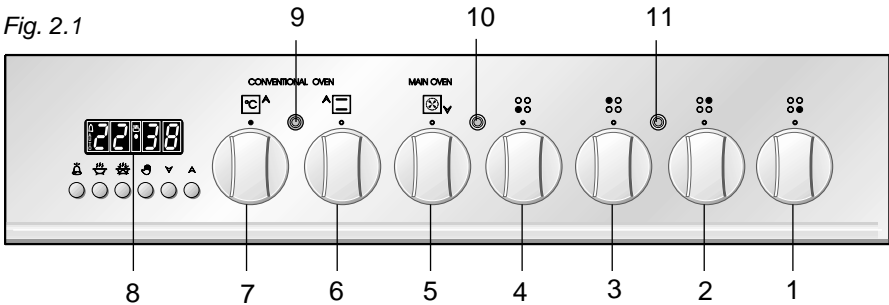

CONTROL PANEL - Controls description

1. Front right hotplate control knob
2. Rear right hotplate control knob
3. Rear left hotplate control knob
4. Front left hotplate control knob
5. Main oven switch and temperature knob
6. Conventional top oven function selector knob
7. Conventional top oven temperature knob
8. Electronic programmer (main oven only)

Pilot lamps:

9. Conventional oven temperature indicator light
10. Main oven temperature indicator light
11. Ceramic hob ON indicator light

3 - USE OF COOKING HOB

The ceramic surface of the hob allows a fast transmission of heat in the vertical direction, from the heating elements underneath the ceramic glass to the pans set on it.

The heat does not spread in a horizontal direction, so that the glass stays “cool” at only a few centimeters from the cooking plate.

The 4 cooking zones are shown by painted disks on the ceramic surface.

IMPORTANT NOTE:

The heating elements incorporate a thermolimiter that switches the element ON/OFF during all settings to protect the ceramic glass from overheating.

The use of incorrect pans and/or wrong pan positioning will cause the temperature limiter to operate more frequently, resulting in a reduction of cooking performance.

3 CIRCUIT RADIANT ZONES

Incorporating 3 heating elements (fig. 3.2) you can control and light up all 3 together or separately by selecting from the 6 positions on the control knob (fig. 3.1).

The working temperature required is reached in a very short time.

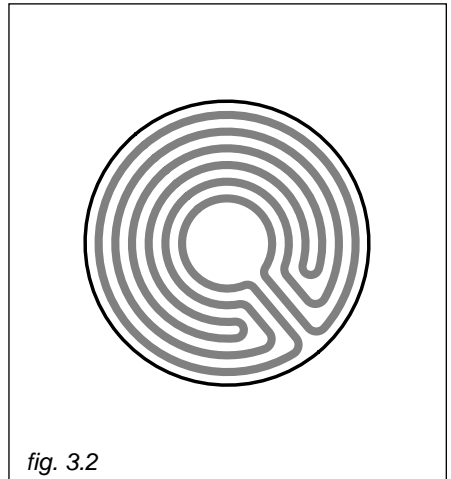
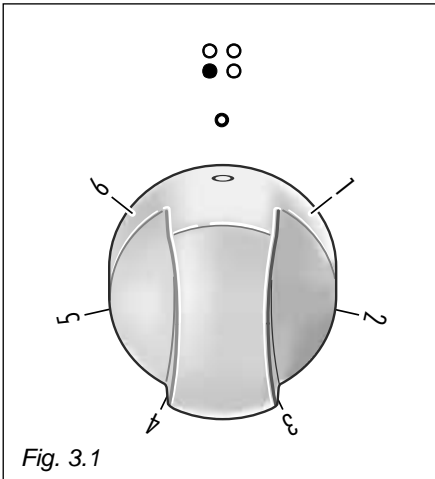

DOUBLE RADIANT ZONE

The heating element is formed of a coil of resistant material which reaches the working temperature quickly.

Operation of the cooking zone is controlled by a continuous energy regulator from "1" to "12" (maximum temperature) (fig. 3.3).

By switching on the second element (fig. 3.4), the surface area of the rear right radiant zone can be extended.

For this purpose, turn the control knob (fig. 3.3) fully to the right (position .

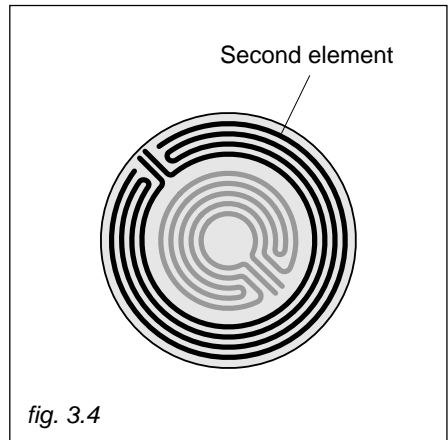
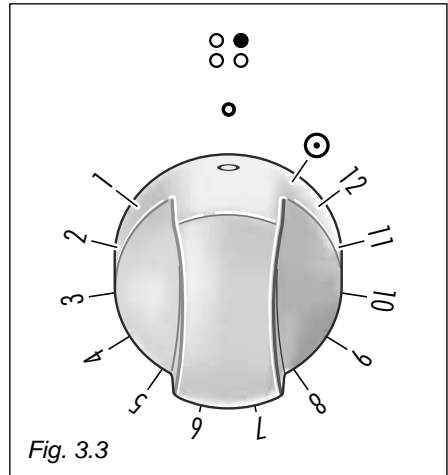

COOKING HINTS

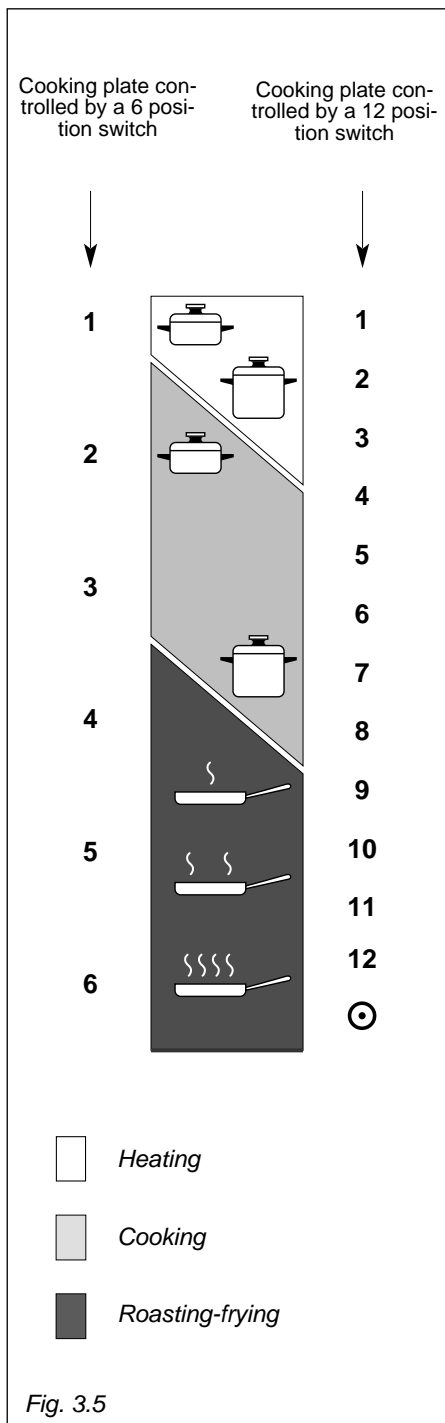

Fig. 3.5

<i>Knob setting</i>		TYPE OF COOKING
0	0	Switched OFF
1	1	For melting operations (butter, chocolate).
2	2	
2	2 3 4	To keep food hot and to heat small quantities of liquid (sauces, eggs).
3	4 5 6	To heat bigger quantities; to whip creams and sauces. (vegetables, fruits, soups).
3	6	Slow boiling, i.e.: boiled meats, spaghetti, soups, continuous steam cooking of roasts, stews, potatoes.
4	7	
4	7 8	For every kind of frying, cutlets, uncovered cooking, i.e.: risotto.
4	8	Browning of meats, roasted potatoes, fried fish, omelettes, and for boiling large quantities of water.
5	9	
5	10	
6	11 12	Fast frying, grilled steaks, etc.
	☉	Switching on the second element (Double and oval radiant plate only)

After a short period of use, experience will teach you which setting is the right one for your needs.

RESIDUAL HEAT INDICATOR

The hob also features 4 warning lights which are connected to the corresponding plates.

When the temperature of a cooking plate is above 60°C, the relevant warning light will also light up to warn of heat on the surface of the hob.

This light also stay on after the cooking plate has been switched off to show that the hob surface is still hot.

This residual heat will lasts for a long time after the cooking plate has been switched off.

During this time you should avoid touching the hob surface over the cooking area.

Please pay special attention to ensure that children are not allowed near the hob.

The light will switch off automatically as soon as the surface temperature of the cooking plate falls below 60°C.

Caution!
the cooking hob becomes very hot during operation.
Keep children well out of reach.

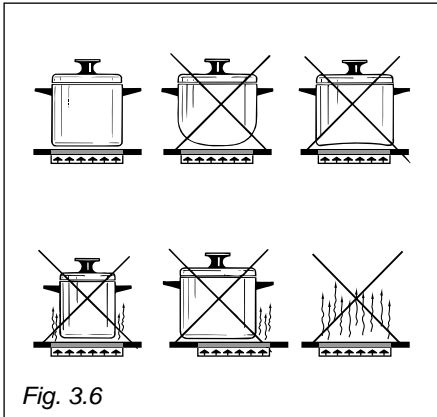

COOKING HINTS:

- To reduce the cooking time, you can turn the control knob to the max when you switch the plate on.
After a short time you can set the control knob to the position required for cooking.
- You should only use pots and pans with flat bases (pans with the test mark for glass-ceramic hobs are available from specialist shops).
The diameter of the pan should match that of the cooking plate (or be slightly bigger) to make the most of the energy.
- Since the cooking surface stays hot for a certain time after the plate has been switched off, you can switch it off 5 or 10 minutes before the end of the cooking.
The residual heat of the hob will complete the cooking.
- To save electricity, use pan lids whenever possible.
- Never cook the food directly on the glass ceramic cooktop.

DEEP FAT FRYING

For safety purposes when deep fat frying, do not fill the pan more than one third full of oil.

DO NOT cover the pan with a lid and **DO NOT** leave the pan unattended.

In the unfortunate event of a fire, leave the pan where it is and turn off the control knobs.

Place a damp cloth or lid over the pan to smother the flames. Leave the pan to cool for at least 30minutes before moving the pan.

DO NOT USE WATER ON THE FIRE.

SAFETY HINTS:

- Before you switch the hob on, make sure you know which knob controls the required cooking plate. We advise you to set the pan over the cooking plate before switching it on. Remove the pan after you have switched the cooking plate off.
- Do not use pots and pans with rough bases (pay attention to cookware made of cast-iron). Rough bases can damage (scratch) the glass surface of the hob. Make sure that the bottom of the pan is dry and clean.
- Pots with aluminium bottoms may leave silver streaks or spots on the hob.
- Do not leave wet or damp lids on the hob.
- The glass-ceramic surface and pans must be clean. Carefully remove any food debris (especially containing sugar), dirt etc. with the aid of a cleansing agent.
- Pan handles should never stand out beyond the kitchen worktop, as there is a great danger of knocking the pan over.
This will also ensure that children cannot reach them.
- **Do not use the hob if the glass surface is broken or cracked in any way. Please disconnect the hob from the mains and contact the after-sales service.**
- Do not lean over the cooking plate when in use.
- Do not lay cooking foil or plastic materials on the ceramic surface when it is hot.
- Remember that the surface remains hot for a long time (about 30 min.) after the cooking plate has been switched off.
- Follow the cleaning instructions carefully.

Do not use the glass surface for storage.

CLEANING

Before you begin cleaning make sure that the appliance is switched off.

Remove spillages and other types of incrustations.

Dust or food particles can be removed with a damp cloth.

If you use a detergent, please make sure that it is not abrasive or scouring. Abrasive or scouring powders can damage the glass surface of the hob.

All traces of the cleaner must be removed with a damp cloth.

Do not put articles on the hob which can melt: i.e plastic, aluminium foil, sugar, sugar syrup mixtures etc.

If any of these products items have melted on the ceramic surface, you should remove it immediately (when the surface is still hot) by using a scraper to avoid any permanent damage to the surface of the hob (Available under part Nr. 103138).

Avoid using a knife or other sharp utensils since these can damage the ceramic.

Do not use steel wool or an abrasive sponge which could scratch the surface permanently.

ATTENTION: MOST IMPORTANT!

If cleaning the glass ceramic hob using a special scraper tool take extra care to avoid damaging the seal at the edges of the glass ceramic surface.

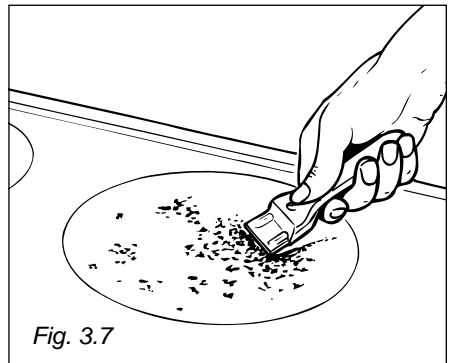

Fig. 3.7

4 - TOP CONVENTIONAL ELECTRIC OVEN



Attention: the oven door becomes very hot during operation. Keep children away.

GENERAL FEATURES

2 different thermostatic control functions are available to satisfy all cooking requirements, provided by 3 heating elements:

- Top element 700 W
- Bottom element 1100 W
- Grill element 2100 W

WARNING:
The door is hot, use the handle.

NOTE: When using for the first time, you are advised to run the oven at maximum temperature (temperature knob set to 250°C) for approximately one hour in the  mode and for another 15 minutes in the  mode in order to eliminate any traces of grease from the heating elements.

OPERATING PRINCIPLES

Heating and cooking in the conventional oven are obtained:

a. by natural convection

The heat is produced by the upper and lower heating elements.

b. by radiation

The heat is radiated by the infrared grill element.

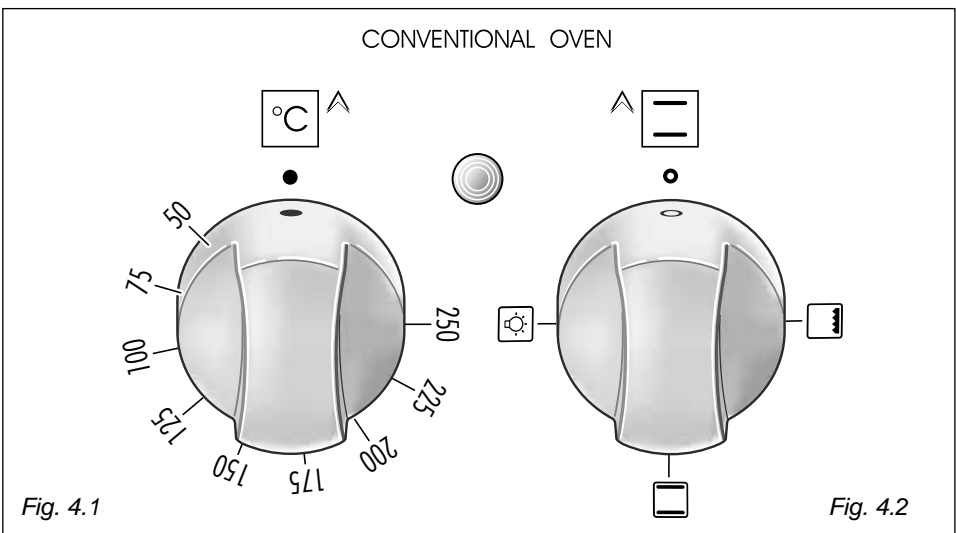

TEMPERATURE KNOB (fig. 4.1)

This only sets the cooking temperature but does not switch the oven on.

Rotate clockwise until the required temperature is reached (from **50** to **250 °C**).

The light above the knob will illuminate when the oven is switched on and turns off when the oven reaches the correct temperature.

The light will cycle on and off during cooking in line with the oven temperature.

FUNCTION SELECTOR KNOB (fig. 4.2)

Rotate the knob clockwise to set the oven for one of the functions described.



OVEN LIGHT

By setting the knob to this position, only the oven light comes on (15 W).

The light remains on whilst any of the cooking modes are selected.



TRADITIONAL CONVECTION COOKING

The upper and lower heating elements are switched on. The heat is diffused by natural convection and the temperature must be set between 50° C and 250° C. It is necessary to preheat the oven before adding the foods to be cooked.

Recommended for:

For foods which require the same cooking temperature both internally and externally, i. e. roasts, spare ribs, meringue, etc.



GRILLING

The infra-red heating element is switched on. The heat is diffused by radiation.

Use with the **oven door closed** and the temperature knob to **175°C**.

Note: It is recommended that you do not grill for longer than 30 minutes at any one time.

Attention: the oven door becomes very hot during operation. Keep children away.

For cooking hints, see the chapter "USE OF THE GRILL".

Recommended for:

Intense grilling, browning, cooking au gratin and toasting etc.

USE OF THE GRILL

Leave to warm up for approximately 5 minutes with the door **closed**.

Place the food inside positioning the rack as near as possible to the grill.

Insert the drip pan under the rack to collect the cooking juices.

Grill with the oven door closed.

Do not grill for longer than 30 minutes at any one time (grilling for longer than the recommended time may mean the appliance overheats).

Attention: the oven door becomes very hot during operation.

Keep children away.

5 - BOTTOM MAIN OVEN

Attention: the oven door becomes very hot during operation. Keep children away.

SWITCH AND TEMPERATURE SELECTOR

Turn the selector knob (fig. 5.1) to the required function.

OFF as per fig. 5.1



The oven light is switched on.

The fan operates without the heating element, this function can be used for defrosting.

50-250°C

The oven light is switched on. The oven temperature can be set between 50°C - 250°C.

The set temperature has been reached when the temperature indicator light goes off.

Several different meals may be cooked simultaneously on various shelves, as the heated air circulates evenly throughout the oven.

The hot air system cooks more quickly than conventional static system, therefore the temperature should be set 15°C - 20°C below the values recommended in your recipe books.

The oven door may be opened briefly while cooking as any heat losses are quickly recovered when the door is closed.

WARNING:

The door is hot, use the handle.

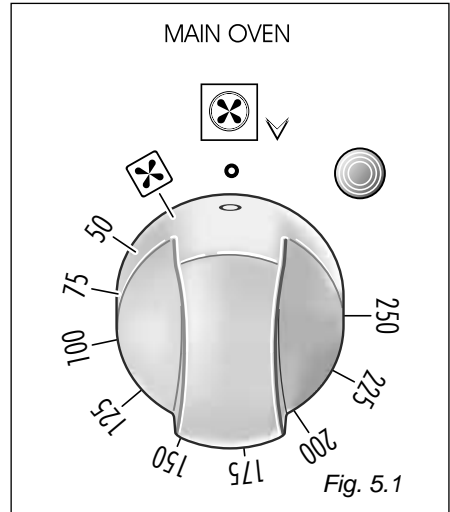

COOKING WITH FORCED AIR

Fan cooking is more economical and quicker than cooking in a conventional oven.

The moving hot air surrounds the food and penetrates it more quickly than in a conventional oven.

The oven can be filled with different dishes all requiring the same cooking temperature. Subtract 10 minutes per hour for every dish requiring a cooking time of more than 1 hour and reduce the heat by 10-20°C; the hotter the oven, the more the temperature can be reduced.

Generally, there is no need to pre-heat the oven, but it is advisable to pre-heat for about 5 minutes to ensure the best results; use the indicator light as a guide, it goes out when the set temperature is reached.

Fan cooking is ideal for gelatine based dishes and softening ice cream - a microwave oven is much too strong for these dishes. Cooking yeast based dishes is also speeded up this way. If the oven door has been opened, the oven quickly regains its temperature once the door is closed.

6 - OVENS COOKING GUIDE

COOKING GUIDE

Temperature and times given are approximate, as they will vary depending on the quality and amount of food being cooked.

Remember to use ovenproof dishes and to adjust the oven temperature during cooking if necessary.

COOKING CHART

Food	Temperature		Cooking Time (approx)
	°C	Gas Mark	
CAKES			
Victoria Sandwich	180	4	20 – 25 mins
Small cakes/buns	180	4	15 – 20 mins
Rich Fruit Cake	150	2	2 hours
Scones	220	7 – 8	8 – 10 mins
Whisked Sponge	190	5	25 mins
BREAD & PASTRY			
Bread Loaf (500g Flour wt)	225	7 – 8	20 – 25 mins
Bread Rolls	225	7 – 8	10 – 15 mins
Pizza Dough	225	8	15 – 20 mins
Shortcrust pastry	200	6	20 – 30 mins
Quiches/Flans	180 - 190	4 - 5	30 – 40mins
ROAST MEATS			
Beef – medium joint	190	5	20 – 25 mins/lb + 20mins
Lamb	190	5	25 – 30mins/lb + 25mins
Pork	190	5	30mins/lb + 30mins
Chicken	190	5	20 – 25mins/lb + 30mins
Turkey	180	4	15 – 20mins/lb + 20mins
Stews/Casseroles	170	3	1½ - 2hours

NOTE: Reduce the oven temperature by 10 – 20°C for fan assisted ovens.
For dishes that take over an hour to cook, reduce the cooking time by 10 minutes per hour.







7 - ELECTRONIC PROGRAMMER (Main oven only)

If you use the oven for none automatic or semi-automatic cooking, ensure programmer is set to manual position by pushing  button.

The electronic programmer performs the following functions:

- 24 hours clock with illuminated display
- Timer (up to 23 hours and 59 minutes)
- Program for automatic oven cooking
- Program for semi-automatic oven cooking.

Description of the buttons:

-  Timer
-  Cooking time
-  End of cooking time
-  Manual position and cancellation of the set cooking program
-  Advance the time for of all programs
-  Decrease the program time and changing the frequency of the audible signal.

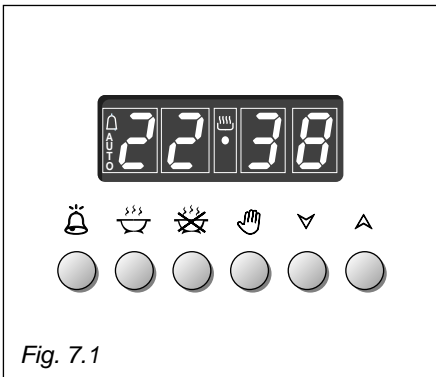



Description of the illuminated symbols:

AUTO - *flashing* - Programmer in automatic position but not programmed



AUTO - *always lit* - Programmer in automatic position with program set.

 Automatic cooking taking place

 Timer in operation

 and **AUTO** - *flashing* - Program error.
(The time of day lies between the calculated cooking start and end time).

Note:



Select a function by the respective button and, within 5 seconds, set the required time with the / buttons ("one-hand" operation).

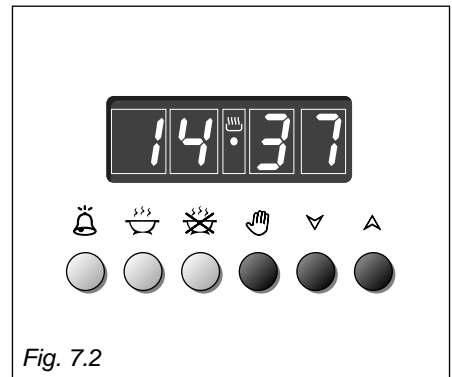



A power cut makes the clock go to zero and cancels the set programs.



ELECTRONIC CLOCK (fig. 7.2)



The programmer is equipped with an electronic clock with an illuminated display which indicates hours and minutes. Upon immediate connection of the oven or after a powercut, three zeros will flash on the display panel.

To set the hour it is necessary to push the  button and then the  or  button until you have set the exact hour (fig. 7.2).

Another way is to simultaneously push the   two buttons and at the same time push the  or  button.

Note: The hour setting deletes any program.

NORMAL COOKING WITHOUT THE USE OF THE PROGRAMMER

To manually use the oven, that is, without the aid of the programmer, it is necessary to cancel the flashing **AUTO** by pushing the button  (**AUTO** will be switched off and the symbol  will come on - Fig. 7.3).

Attention: If the **AUTO** is steadily lit (which means a cooking program has already been set), the program can be cancelled and switched to manual by pushing the button .

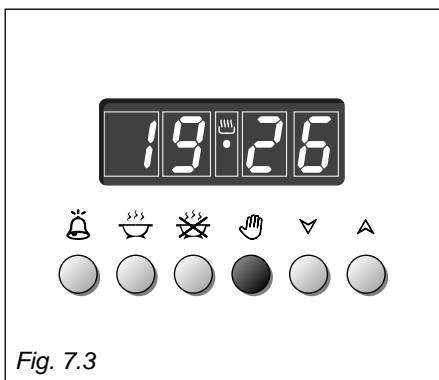

If the oven is switched on, you must switch off manually.





ELECTRONIC TIMER

The timer program consists only of a buzzer which may be set for a maximum period of 23 hours and 59 minutes.

If the **AUTO** is flashing push the  button.

To set the time, push the  button and the  or  until you obtain the desired time in the panel (fig. 7.4).

Having finished the setting, the clock hour will appear on the panel and the  symbol will be lit.

The countdown will start immediately and may be seen at any moment on the panel by simply pressing the button .

At the end of the time, the  symbol will be switched off and an intermittent buzzer will go off; this can be stopped by pressing any of the buttons.

SETTING THE FREQUENCY OF THE AUDIBLE SIGNAL

3 possible sounds can be selected by pressing the  button.

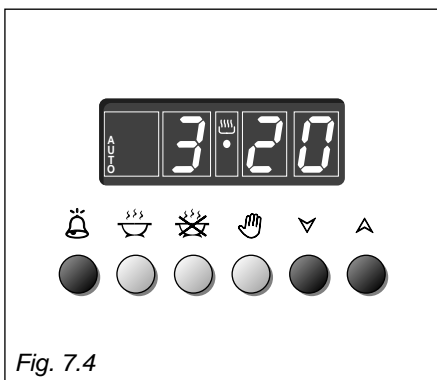









AUTOMATIC OVEN COOKING

To cook food automatically in the oven, it is necessary to:

1. Set the length of the cooking time
2. Set the end of the cooking time
3. Set the temperature and the oven cooking program.

These operations are done in the following way:

1. Set the length of the cooking time required by pushing the  button and the  button to advance, or  to go back if you have passed the desired time (fig. 7.5). The **AUTO** and the  symbol will be on.
2. Set the time you need the food to stop cooking by pushing the  button (the cooking time already added to the clock time will appear), and the  button (fig. 7.6); if you pass the desired time you can go back by pushing the  button.

After this setting, the  symbol will go off. If after this setting, the **AUTO** flashes on the panel and a buzzer goes off, it means there was an error in the programming, that is the the cooking cycle has been superimposed on the clock. In this case, change the end of cooking time or the cooking time itself by following the instructions above.

3. Set the temperature and the cooking program (see the relevant sections).

Once the oven is programmed it will switch on automatically at the right time to stop the cooking at the desired end time.

During cooking, the  symbol remains on.

By pushing the  button you can see the time that remains until the end of cooking.

The cooking program may be cancelled at any time by pushing .

At the end of the cooking time the oven will turn off automatically, the  symbol will turn off, **AUTO** will flash and the buzzer will sound, which can be turned off by pushing any of the buttons.

Turn the switch and temperature knobs to "OFF" and put the programmer onto "manual" by pressing the .

Attention: A powercut will make the clock go to zero and will cancel the set programs.

After a powercut, three zeros will flash on the panel.

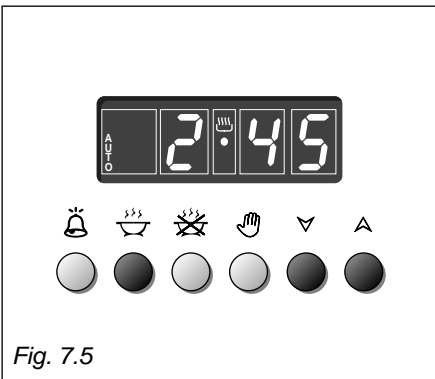

Fig. 7.5

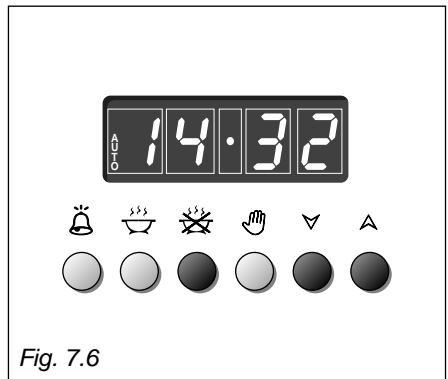





Fig. 7.6



SEMI - AUTOMATIC COOKING

This is used to switch the oven off automatically after the desired cooking time has elapsed.

There are two ways to set the semi-automatic cooking function:



1. Set the length of time you need to cook the food by pushing the  button and the  button to advance, or  to go backwards (Fig. 7.7). This sets the desired "stop" time.

or

2. Set the time you need the food to stop cooking by pushing the  button and the  button to advance, or  to go backwards if you have passed the desired time (Fig. 7.8).

AUTO and the  symbol will be on.

Then set the temperature and the cooking program (see the relevant sections). The oven is switched on and it will switch off automatically at the end of the desired time.

During cooking, the  symbol remains on and by pressing the  you can see the time that remains until the end of the cooking.

The cooking program can be cancelled at any moment by pushing the  button.

At the end of the cooking, the oven and the  symbol will turn off, the **AUTO** will flash and a buzzer will go off which can be stopped by pushing any of the buttons.

Turn the switch and temperature knobs to "OFF" and put the programmer onto "manual" by pressing the  button.

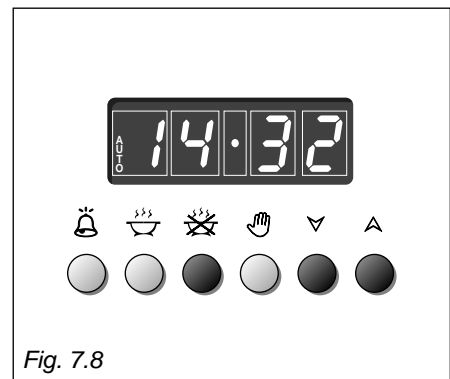
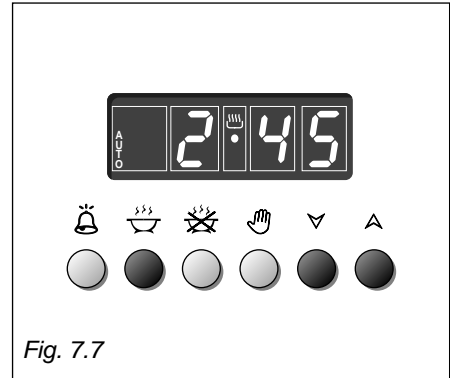

8 - CLEANING AND MAINTENANCE

Important:

Before cleaning or carrying out any maintenance disconnect the appliance from the electrical supply and wait for it to cool down.

Attention

The appliance gets very hot, mainly around the cooking areas. It is very important that children are not left alone in the kitchen when you are cooking.

Do not use a steam cleaner because the moisture can get into the appliance thus make it unsafe.

STAINLESS STEEL SURFACES (COATED)

The stainless steel front panels on this cooker (facia, oven door) are protected by a finger-print proof lacquer.

To avoid damaging this lacquer, do not clean the stainless steel with abrasive cleaners or abrasive cloths or scouring pads.

ONLY SOAPY/WARM WATER MUST BE USED TO CLEAN THE (COATED) STAINLESS STEEL SURFACES.

STAINLESS STEEL SURFACES (UNCOATED)

The hob + sides are made from un-coated stainless steel and can be cleaned with an appropriate stainless steel cleaner.

ENAMELLED PARTS

All the enamelled parts must be cleaned with a sponge and soapy water or other non-abrasive products.

Dry preferably with a soft cloth.

Acidic substances like lemon juice, tomato sauce, vinegar etc. can damage the enamel if left in contact for too long.

VITROCERAMIC COOKING HOB

– See page 13

OVEN

The oven with smooth enamel must be cleaned after every use using a suitable product.

Remember that operating the oven for 30 minutes on the highest temperature eliminates most grime and grease.

It is mandatory not to use abrasive substances.

REPLACING THE OVEN LIGHT BULB

Switch the cooker off at the mains.

When the oven is cool, unscrew and replace the bulb with another one resistant to high temperatures (300°C), voltage 230 V (50 Hz), 15 W, E14.

Note: Oven bulb replacement is not covered by your guarantee.

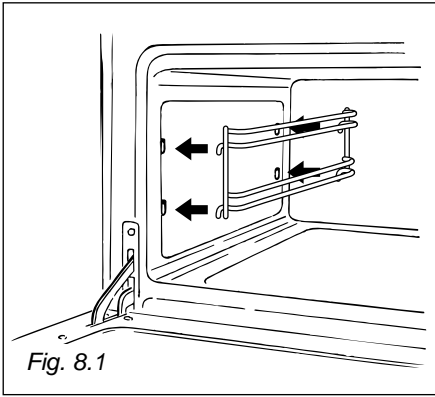

Fig. 8.1

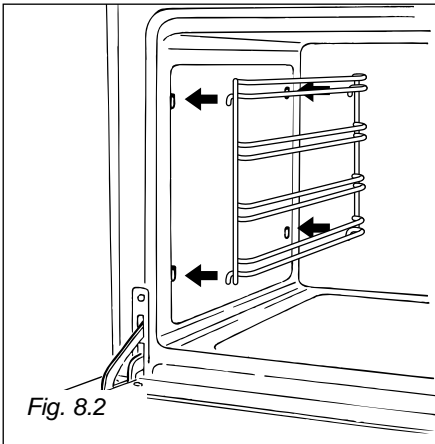

Fig. 8.2

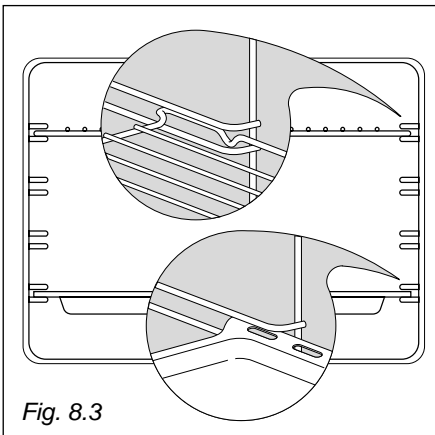

Fig. 8.3

USING THE TOP AND THE MAIN OVEN FOR THE FIRST TIME

You are advised to carry out the following operations:

- Clean the inside of the two ovens with a cloth soaked in water and neutral detergent and dry thoroughly.
- Hang up the wire racks on the oven walls (Figure 8.1 and 8.2).
- Slide in, on the guides, the shelf and the tray etc. (Figure 8.3). The shelf must be fitted so that the safety catch, which stops it sliding out, faces the inside of the oven.
- To eliminate traces of grease from the heating elements, switch on the ovens to the maximum temperature.
- Dismantle in reverse order.

OVEN DOOR

The internal glass of the oven door can be easily removed for cleaning by unscrewing the two lateral fixing screws (fig. 8.4).

Attention: Do not store flammable material in the oven.

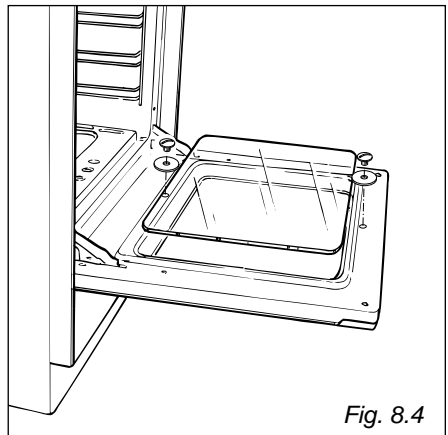

Fig. 8.4

Type A

REMOVING THE OVEN DOOR

To facilitate oven cleaning, it is possible to remove the door.

Please follow the instructions carefully:

- Open the door completely.
- Push down the lever “L” and, keeping it in this position, slowly close the door in order to block the hinge.
- Grip the door (as indicated in fig. 8.6) and, while closing it, release the two hinges as shown in fig. 8.7.

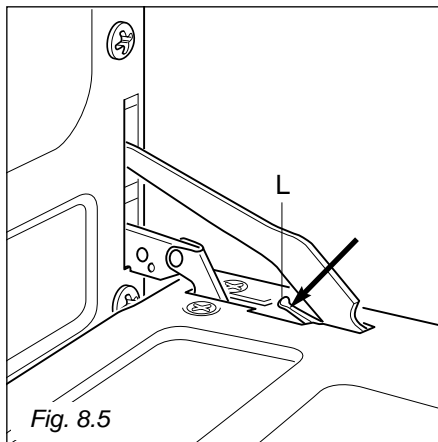

Fig. 8.5

DOOR ASSEMBLY

- Grip the door with your hands placed near the hinges and raise the levers “H” with your forefingers (fig. 8.7)
- Insert the hinges in their position until levers “H” are hooked.
- Open the door completely to obtain the release of levers “L”.

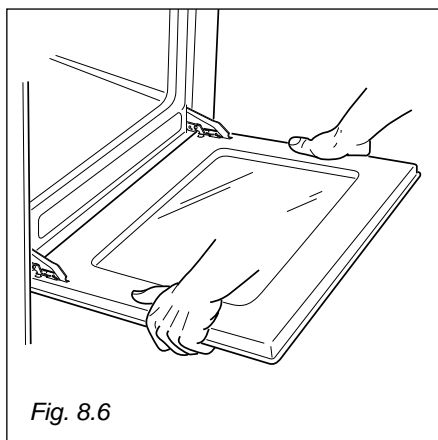

Fig. 8.6

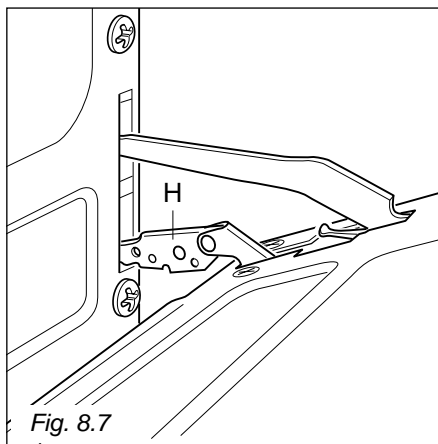

Fig. 8.7

Type B

REMOVING THE OVEN DOOR

The oven door can easily be removed as follows:

- Open the door to the full extent (fig. 8.8A).
- Attach the retaining rings to the hooks on the left and right hinges (fig. 8.8B).
- Hold the door as shown in fig. 8.8.
- Gently close the door and withdraw the lower hinge pins from their location (fig. 8.8C).
- Withdraw the upper hinge pins from their location (fig. 8.8D).
- Rest the door on a soft surface.
- To replace the door, repeat the above steps in reverse order.

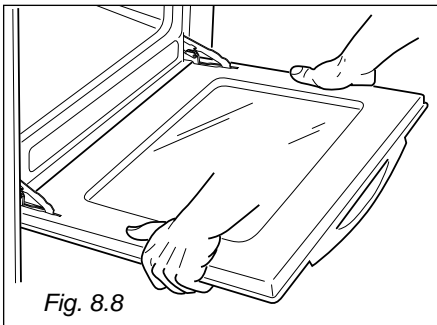
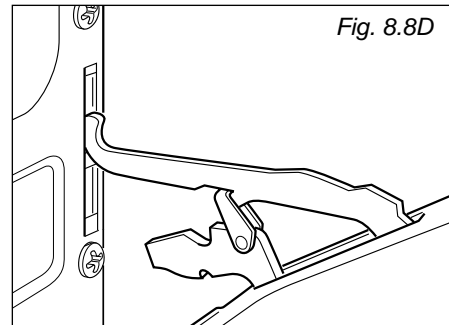
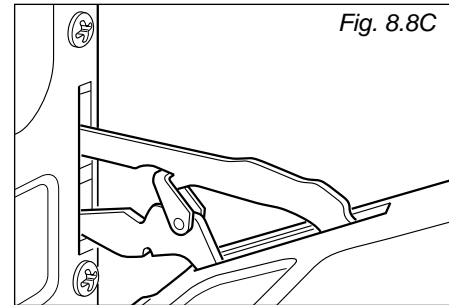
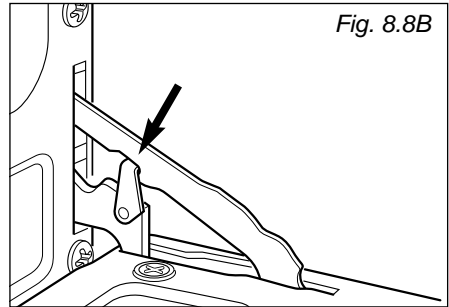
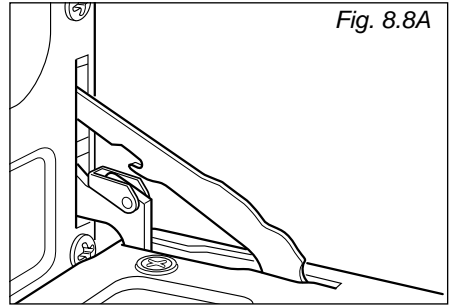

Advice for the installer

IMPORTANT

- The appliance should be installed by a qualified technician in compliance with the laws in force in your country and in observation of the instructions supplied by the manufacturer.
- Always disconnect the cooker from mains power supply before carrying out any maintenance operations or repairs.
- Some appliances are supplied with a protective film on steel and aluminium parts. This film must be removed before using the appliance.

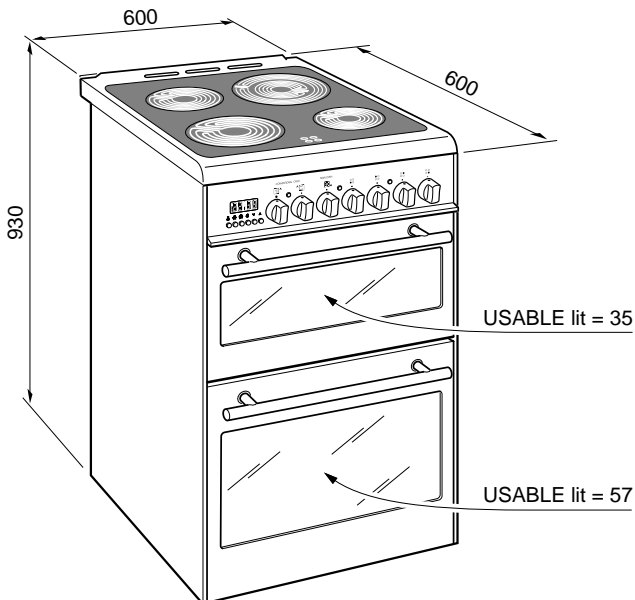

INSTALLATION

The appliance must be kept no less than 50 mm away from any side wall which exceed the height of the cooktop (fig. 9.1).

The furniture walls adjacent to the cooker must be made of heat-resistant material.

The veneered synthetic material and the glue used must be resistant to a temperature of 90°C in order to avoid ungluing or deformations.

The cooker may be located in a kitchen, a kitchen/diner or bed-sitting room but not in a room containing a bath or shower.

Curtains must not be fitted immediately behind appliance or within 500 mm of the sides.

It is essential that the cooker is positioned as stated opposite.

Secure the four feet in the holes on the base of the appliance and adjust the height.

If the cooker is located on a pedestal it is necessary to provide safety measures to prevent it falling out.

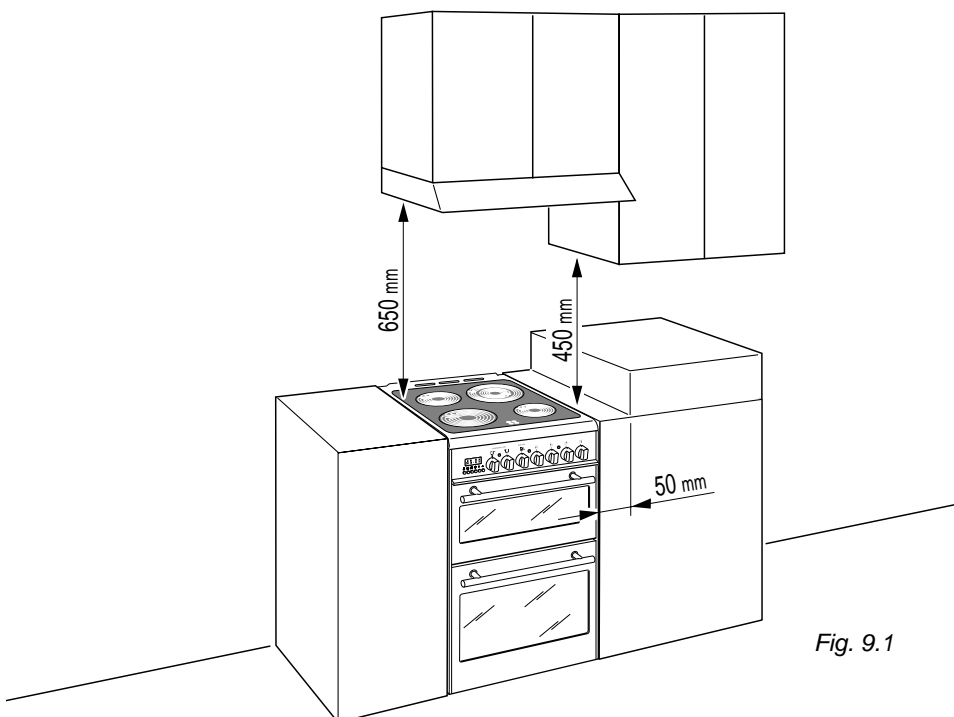

Fig. 9.1

10 - ELECTRICAL SECTION

IMPORTANT: The appliance must be installed in accordance with the manufacturer's instructions. Incorrect installation, for which the manufacturer accepts no responsibility, may cause damage to persons, animals and things.

GENERAL

- Connection to the mains must be carried out by qualified personnel in accordance with current regulations.
- The appliance must be connected to the mains checking that the voltage corresponds to the value given in the rating plate and that the electrical cable sections can withstand the load specified on the plate.
- The cooker can be connected directly to the mains placing an omnipolar switch with minimum opening between the contacts of 3 mm between the appliance and the mains.
- The power supply cable must not touch the hot parts and must be positioned so that it does not exceed 75°C at any point.
- Once the cooker has been installed, the switch or socket must always be accessible.

Before effecting any intervention on the electrical parts of the appliance, the connection to the network must be interrupted.

N.B. For connection to the mains, do not use adapters, reducers or branching devices as they can cause overheating and burning.

If the installation requires alterations to the domestic electrical system call an expert.

He should also check that the socket cable section is suitable for the power absorbed by the appliance.

IMPORTANT: this cooker must be connected to a suitable double pole control unit adjacent to the cooker.

NO DIVERSITY CAN BE APPLIED TO THIS CONTROL UNIT.

**IMPORTANT:
This appliance must be earthed.**

The connection of the appliance to earth is mandatory.

The manufacturer declines all responsibility for any inconvenience resulting from not observing this condition.

CONNECTING THE MAINS CABLE

- Remove the two screws securing the cover plate A behind the cooker.
- Remove the screw C from the cable clamp.
- Insert the mains cable (type H05RR-F) of minimum 6 mm² section into the cable protector P.
- Connect the phase and earth cables to the mains terminal connection block B.

⊥	EARTH
N	NEUTRAL
L	LIVE

- Refit the cable clamp so that it clamps the outer sleeving of the cable.
- Refit the cover plate A.

TECHNICAL DATA

230 V AC - 50 Hz

Top conventional oven

– Top element	0.70 kW
– Bottom element	1.10 kW
– Grill element	2.10 kW

Bottom fan oven

– Fan element	2.50 kW
---------------	---------

Vitroc ceramic hob

– Front left	1.70 kW
– Back left	1.20 kW
– Back right	2.10 kW
– Front right	1.20 kW

Maximum power rating

– Top oven	2.10 kW
– Bottom oven	2.50 kW

Oven lamp

0.015 kW
300 °C, miniature edison screw

Fan motor

0.025 kW

Maximum usable power (diversity not applied)

10.86 kW

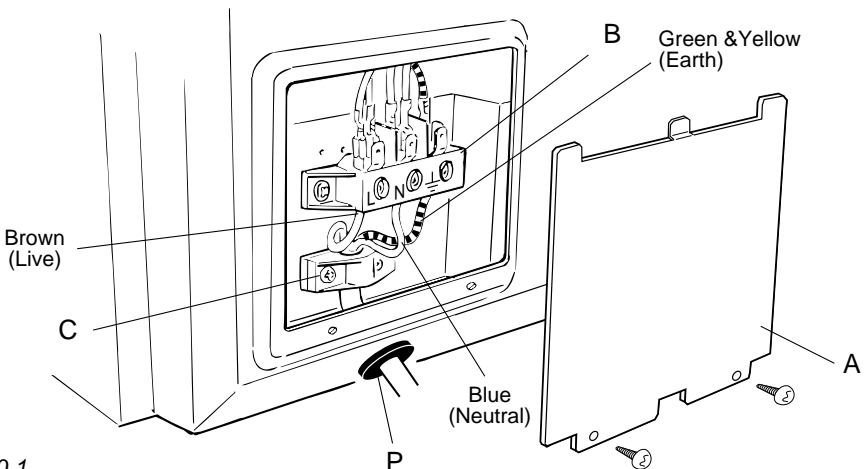

Fig. 10.1

GUARANTEE

UK only

If your appliance goes wrong within one year from the date you bought it, we will repair it (or replace it if necessary) free of charge provided:

- you have not misused, neglected, or damaged it;
- it has not been modified;
- it is not second hand;
- it has not been used commercially;
- you have not fitted a plug incorrectly; and
- you supply your receipt to show when you brought it.
- The appliance has been installed as per the instructions contained within this booklet.

This guarantee does not affect your statutory rights.

AFTER SALES SERVICE

If you require After Sales Service contact the MASTERCARE Domestic Appliance Helpline Telephone 08701 565550.

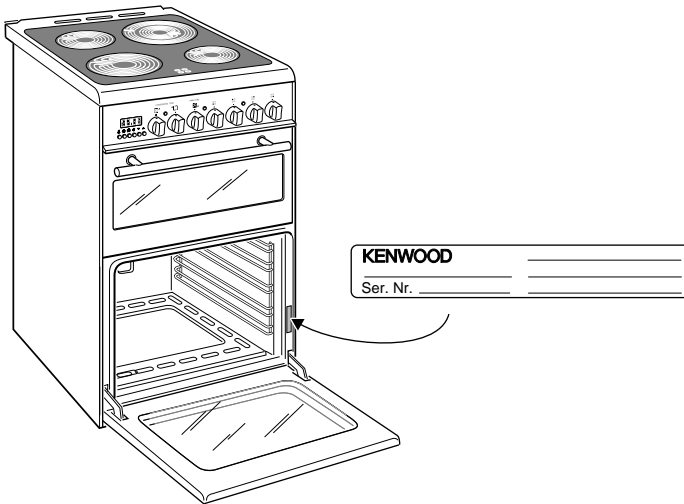

Descriptions and illustrations in this booklet are given as simply indicative.
The manufacturer reserves the right, considering the characteristics of the models described here, at any time and without notice, to make eventual necessary modifications for their construction or for commercial needs.

KENWOOD

Kenwood Ltd, New Lane, Havant, Hampshire PO9 2NH

code 1102198 B4

Part Number 55159