

Installation, commissioning and servicing instructions

Wall hung RSF gas fired condensing combi boiler

Greenstar i^{ErP}

For central heating systems and mains fed domestic hot water



**These appliances are for use with:
Natural Gas or L.P.G.
(Cat. II 2H 3P type C13, C33 & C53)**

	Model	GC Number
Natural Gas	Greenstar 25i ^{ErP}	47-406-60
	Greenstar 30i ^{ErP}	47-406-62
L.P.G.	Greenstar 25i ^{ErP}	47-406-61
	Greenstar 30i ^{ErP}	47-406-63

If you smell gas:

- ▶ Well away from the building: call the National Gas Emergency Service on 0800 111 999.
- ▶ L.P.G. boilers: Call the supplier's number on the side of the gas tank.



Contents

1	Key to symbols and safety instructions	4	6	Commissioning	34
1.1	Key to symbols	4	6.1	Pre-Commissioning checks	34
1.2	Safety precautions	5	6.2	Filling the system	34
2	Regulations	6	6.3	Water treatment	34
3	Appliance information	7	6.4	Starting the appliance	35
3.1	Appliance	7	6.4.1	Appliance start up screens	35
3.2	Technical data	8	6.4.2	Info menu and operational status codes	36
3.3	Energy efficiency	9	6.5	Commissioning	38
3.4	Layout	10	6.5.1	Checking the gas inlet pressure	38
3.4.1	Electrical diagram	12	6.5.2	Gas pressure within the system	38
4	Pre-installation	14	6.5.3	Checking the gas rate	39
4.1	Cleaning primary systems	14	6.5.4	Gas rate testing	39
4.2	Mains supply	14	6.5.5	Checking for leaks during operation	39
4.2.1	Electrical supply	14	6.5.6	Domestic hot water	39
4.2.2	Gas supply	14	6.5.7	CO and combustion checks	40
4.2.3	Water supply	15	6.5.8	Checking flue integrity	41
4.3	Water systems and pipe work	15	6.5.9	Flue gas analysis	41
4.3.1	Available pump head	16	6.5.10	Service reminder function	42
4.4	Appliance location and clearances	16	6.5.11	Benchmark menu	42
4.4.1	Installation	16	6.5.12	Weather sensor settings menu	42
4.4.2	Installation and servicing clearances	17	6.5.13	Boiler settings menu	43
4.4.3	Compartments	17	6.5.14	Master settings menu	44
4.4.4	Rooms containing a bath or shower	17	6.6	Finishing commissioning	44
4.5	Pressure relief pipe work	17	6.6.1	Replace front panel:	44
4.6	Condensate discharge	18	6.6.2	Fitting fascia flap	44
4.6.1	Appliance siphonic condensate trap	18	6.6.3	Installing bottom panel	45
4.6.2	Condensate pipe work	18	6.6.4	Setting the central heating temperature	45
4.6.3	Internal connections	18	6.6.5	Setting the domestic hot water temperature	45
4.6.4	External connections	19	6.6.6	Eco/Preheat mode activation	46
4.7	Standard accessories	20	6.6.7	Toggle basic adjust mode	46
4.8	Plumbing manifold	21	6.6.8	Hand over	46
4.8.1	Connections	21	6.6.9	Appliance guarantee	47
4.9	Flue options	21	7	Service and spares	47
4.9.1	Flue lengths	21	7.1	Inspection and service	47
4.9.2	Determine the plume management system length	23	7.1.1	History menu	48
4.10	Flue terminal positions	24	7.1.2	Test menu	48
4.11	Plume management terminal positions	26	7.2	Checking flue integrity	48
5	Installation	27	7.3	Check the gas inlet pressure	48
5.1	Important handling instructions	27	7.4	Fan pressure test	49
5.2	Wall mounting template & flue openings	27	7.5	Flue gas analysis	50
5.3	Appliance connections	28	7.6	Cleaning the siphon and heat exchanger	50
5.3.1	Front panel removal	29	7.6.1	Cleaning the siphon	50
5.3.2	Hanging the appliance	29	7.6.2	Refitting the siphon after cleaning	51
5.3.3	Pressure relief connections	29	7.6.3	Remove access cover panel	51
5.3.4	Siphon removal	29	7.6.4	Cleaning the primary heat exchanger	52
5.3.5	Reconnecting the siphon	30	7.7	Replacement of parts	52
5.3.6	Filling the siphon	30	7.7.1	Component access	52
5.4	Flue turret/adaptor installation	30	7.7.2	Siphon removal replacement of parts	53
5.5	Electrical	31	7.7.3	Draining the appliance	53
5.5.1	Mounting optional plug-in controls	32	7.7.4	Fan assembly removal	53
5.5.2	External controls - domestic installations	33	7.7.5	Air/gas manifold clamping plate removal	54
			7.7.6	Burner and electrode removal	54
			7.7.7	Baffle removal	54
			7.7.8	Flow pipe removal	55
			7.7.9	Exhaust assembly removal	55
			7.7.10	Heat exchanger removal	56

7.7.11	Re-assembly of the air/gas manifold clamping plate ..	56
7.7.12	Primary sensor (CH NTC)	56
7.7.13	Overheat thermostat	56
7.7.14	Spark generator	57
7.7.15	Flue overheat thermostat (with grommet)	57
7.7.16	Fan	57
7.7.17	Gas valve	58
7.7.18	Expansion vessel removal	58
7.7.19	PCB fuse	58
7.7.20	Replacing control unit	58
7.7.21	Hydraulic block components removal	59
7.7.22	DHW temperature sensor	59
7.7.23	Auto air vent	59
7.7.24	Flow turbine, flow regulator assembly and filter	60
7.7.25	Diverter valve motor	60
7.7.26	Diverter valve	60
7.7.27	Drain tap	61
7.7.28	Pump head	61
7.7.29	Pressure gauge	61
7.7.30	DHW pressure relief valve	61
7.7.31	Hydraulic block removal	61
7.7.32	CH pressure relief valve	62
7.7.33	Bypass valve	62
7.7.34	DHW plate heat exchanger	62
7.8	Short parts list	62

8	Fault finding and diagnosis	63
8.1	Fault finding	63
8.1.1	Maintenance Menu	64
8.1.2	Error codes	65
8.1.3	Factory Reset	68
8.2	Component resistance characteristics	69
8.2.1	Flow temperature NTC sensor	69
8.2.2	DHW NTC sensor	69
8.2.3	Flue overheat thermostat	69
8.2.4	Overheat thermostat	69
8.2.5	Outdoor weather compensation sensor	69
8.2.6	Gas valve resistances	69
8.3	Central heating function	70
8.4	Preheat and DHW function	71
8.5	Protection function	72

1 Key to symbols and safety instructions

1.1 Key to symbols

Warnings

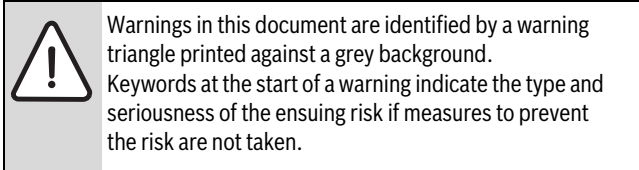

The following keywords are defined and can be used in this document:

- **NOTICE** indicates a situation that could result in damage to property or equipment.
- **CAUTION** indicates a situation that could result in minor to medium injury.
- **WARNING** indicates a situation that could result in severe injury or death.
- **DANGER** indicates a situation that will result in severe injury or death.

Important information

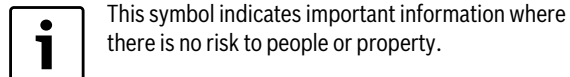

Additional symbols

Symbol	Meaning
1.	a numbered step in an action sequence
▶	a step in an action sequence
→	a reference to a related part in the document or to other related documents
①	a reference number to identify or refer to a part or item
.	a list entry
-	a list entry (second level)

Table 1 Symbols

Examples of additional symbols used

A numbered step in an action sequence

A sequence of numbered steps or actions carried out in a specific order to complete a task.

1. First action
 2. Second action
 3. Third action
- etc.

A step in an action sequence

A sequence of defined actions or steps carried out in order to complete a task.

- ▶ Action
- ▶ Next action
- ▶ etc.

A reference to a related part in the document or to other related documents.

To refer the reader to a specific figure/table/section within the manual.

→ e.g. figure 1.

A reference number to identify or refer to a part or item.

In a related figure, items or parts identified by a sequential number.

List entries, first and second levels

- A single component/item
- A component/list, made up of multiple parts/items.
 - Sub component or sublist of main component/list.
 - etc.

SYMBOLS USED IN THIS MANUAL





	Domestic Hot Water
	Central Heating
	Hot Water Storage Cylinder
	Domestic Cold Water Supply
	Gas Supply

Table 2 Commonly used symbols

PLEASE READ THESE INSTRUCTIONS CAREFULLY BEFORE STARTING INSTALLATION.

These instructions are applicable to the Worcester appliance model(s) stated on the front cover of this manual only and must not be used with any other make or model of appliance.

These instructions apply in the UK and Ireland only and must be followed except for any statutory obligations.

This appliance must be installed and serviced by a **GAS SAFE** registered, competent person. Failure to install correctly could lead to prosecution.

If you are in any doubt, contact the Worcester Technical helpline (0330 123 3366).

Please leave these instructions with the completed BENCHMARK CHECKLIST, (or a certificate confirming compliance with IS 813, Eire only) and the user manual with the owner or at the gas meter after installation or servicing.

Distance learning and training courses are available from Worcester.

The BENCHMARK CHECKLIST can be found in the back of this Installation manual.

∅	Diameter
NG	Natural Gas
LPG	Liquid Petroleum Gas
CH	Central Heating
DHW	Domestic Hot Water
DCW	Domestic Cold Water
DWTA	Domestic Water Treatment Association
PRV	Pressure Relief Valve
NTC	Negative Temperature Coefficient (sensor)
IP	Ingress Protection
RCD	Residual Current Device
TRV	Thermostatic Radiator Valve
ECV	Emergency Control Valve
WRAS	Water Regulations Advisory Scheme
SEDBUK	Seasonal Efficiency of Domestic Boilers in the United Kingdom

Table 3 Abbreviations use in this manual

1.2 Safety precautions

If you smell gas

A gas leak could potentially cause an explosion. If you smell gas, observe the following rules.

- ▶ Prevent flames or sparks:
 - Do not smoke, use a lighter or strike matches.
 - Do not operate any electrical switches or unplug any equipment.
 - Do not use the telephone or ring doorbells.
- ▶ Turn off the gas at the meter or regulator.
- ▶ Open windows and doors.
- ▶ Warn your neighbours and leave the building.
- ▶ Prevent anyone from entering the building.
- ▶ Well away from the building: call the National Gas Emergency Service on 0800 111 999.
- ▶ L.P.G. boilers: Call the supplier's number on the side of the gas tank.

Appliance operation:

The following requirements apply in accordance with EN60335-1 to prevent hazards from occurring when using electrical appliances.

This appliance can be used by children aged from 8 years and above and persons with reduced physical, sensory or mental capabilities or lack of experience and knowledge, if they have been given supervision or instruction concerning the use of the appliance, in a safe way, and understand the hazards involved.

Children shall not play with the appliance.

Cleaning and user maintenance shall not be made by children without supervision.



Benchmark places responsibilities on both manufacturers and installers.

The purpose is to ensure

that customers are provided with the correct equipment for their needs, that it is installed, commissioned and serviced in accordance with the manufacturer's instructions by competent persons and that it meets the requirements of the appropriate Building Regulations. The Benchmark Checklist can be used to demonstrate compliance with Building Regulations and should be provided to the customer for future reference.

Installers are required to carry out installation, commissioning and servicing work in accordance with the Benchmark Code of Practice which is available from the Heating and Hotwater Industry Council who manage and promote the scheme.

Visit centralheating.co.uk for more information.

Health and safety

The appliance contains no asbestos and no substances have been used in the construction process that contravene the COSHH Regulations (Control of Substances Hazardous to Health Regulations 1988).

Combustion and corrosive materials

Do not store or use any combustible materials (paper, thinners, paints etc.) inside or within the vicinity of the appliance.

Chemically aggressive substances can corrode the appliance and invalidate any warranty.

Fittings and modifications

Fitting the appliance and any controls to the appliance may only be carried out by a competent engineer in accordance with the current Gas Safety (Installation and Use) Regulations.

Flue systems must not be modified in any way other than as described in the fitting instructions. Any misuse or unauthorised modifications to the appliance, flue or associated components and systems could invalidate the warranty. The manufacturer accepts no liability arising from any such actions, excluding statutory rights.

Servicing

Advise the user to have the system serviced annually by a competent, qualified Gas Safe registered engineer. Approved spares must be used to help maintain the economy, safety and reliability of the appliance.

Important

The service engineer must complete the Service Record on the Benchmark Checklist after each service.

Flue System



Only use the approved Worcester Condensfit II flue system with this appliance.

Worcester original spare parts

Only use Worcester original spare parts with this appliance.

Non Worcester original spare parts will invalidate the guarantee (if applicable) and any warranty.

2 Regulations

Installation regulations

Current Gas Safety (Installation & Use) Regulations:

All gas appliances must be installed by a competent person in accordance with the above regulations.

Failure to install appliances correctly could lead to prosecution.

The appliance must be installed in accordance with, and comply to, the current: Gas Safety Regulations, IET Regulations, Building Regulations, Building Standards (Scotland) (Consolidation), Building Regulations (Northern Ireland), local water by-laws, Health & Safety Document 635 (The Electricity at Work Regulations 1989), EU Regulations No. 811/2013 - Energy Labelling and any other local requirements.

British standards

Where no specific instruction is given, reference should be made to the relevant British Standard codes of Practice.

BS7074:1	Code of practice for domestic and hot water supply
BS6891	Installation of low pressure gas pipe work up to 28mm (R1)
BS5546	Installation of gas hot water supplies for domestic purposes
EN12828	Central heating for domestic premises
BS5440:1	Flues and ventilation for gas appliances of rated heating not exceeding 70kW (net): Flues
BS5440:2	Flues and ventilation for gas appliances of rated heating not exceeding 70kW (net): Air Supply
BS7593	Treatment of water in domestic hot water central heating systems
BS6798	Installation of gas fired boilers of rated input up to 70kW (net)

L.P.G. Installations

An appliance using L.P.G. must not be installed in a room or internal space below ground level unless one side of the building is open to the ground.

Irish Standards

The relevant Irish standards should be followed, including:

- ECTI National rules for electrical installations
- IS 813:2002 for Domestic Gas Installations.

Timber Framed Buildings

Where the boiler is to be fitted to a timber framed building the guidelines laid down in BS5440: Part 1 and IGE "Gas Installations in Timber Frame Buildings" should be adhered to.

Potable Water

All seals, joints and compounds (including flux and solder) and components used as part of the secondary domestic water system must be approved by WRAS.

CH Water

Artificially softened water must not be used to fill the central heating system.

3 Appliance information

3.1 Appliance

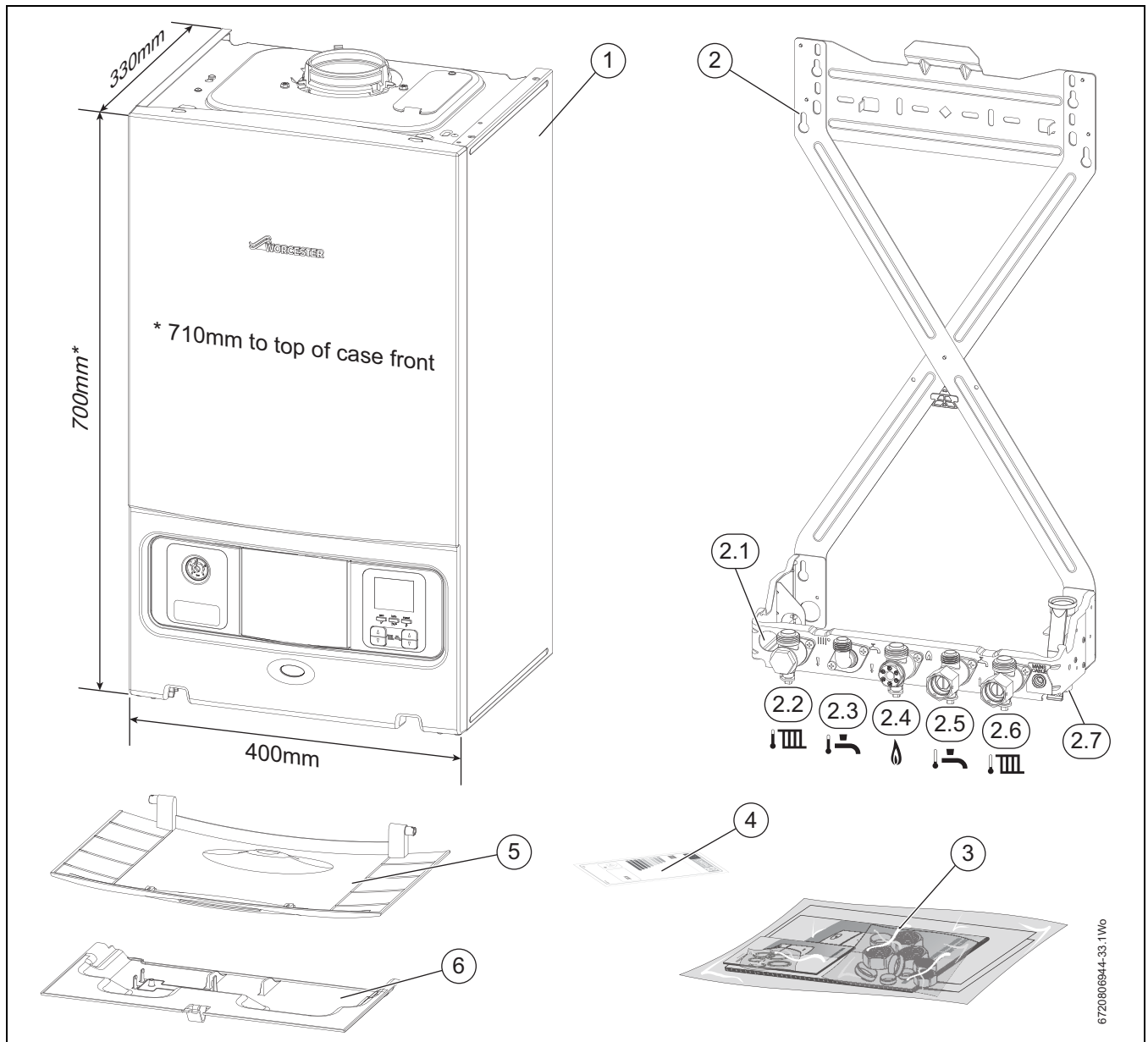

Fig. 1 Standard package

- [1] Wall hung gas-fired condensing combi appliance for central heating and domestic hot water.
- [2] Wall mounting frame.
 - [2.1] Condensate pipe routing.
 - [2.2] CH Flow.
 - [2.3] DHW Outlet.
 - [2.4] Gas.
 - [2.5] DCW Mains In.
 - [2.6] CH Return.
 - [2.7] Pressure Relief Valve outlet.
- [3] Hardware literature pack:
 - Installation, Commissioning and Servicing Instructions
 - User guide
 - Wall mounting template
 - Sealing Pack
- [4] ErP label.
- [5] Facia panel.
- [6] Bottom panel.

3.2 Technical data

DESCRIPTION	UNIT	Natural gas			L.P.G.	
		25kW	Low NOx 25kW/30kW	30kW	25kW	30kW
Domestic Hot Water						
Minimum heat input	kW	7.14	Low NOx only applies to Central Heating	7.14	9.58	9.58
Maximum rated heat output	kW	25		30	25	30
Maximum rated heat input	kW	25.51		30.61	25.51	30.61
Maximum mains inlet pressure (standing pressure)	bar	10		10	10	10
Minimum mains inlet pressure (working) for max. flow	bar	1.3		2	1.3	2
Minimum mains inlet pressure (working) for operation	bar	0.2		0.2	0.2	0.2
Minimum required flow to activate DHW demand	l/min.	2.9		2.9	2.9	2.9
Domestic Hot Water temperature range	°C	40 - 60		40 - 60	40 - 60	40 - 60
¹⁾ Max. Domestic Hot Water flow rate - 40 °C rise ± 15%	l/min.	9		11	9	11
Gas flow rate - Max. 10 minutes from lighting						
Natural Gas ²⁾	m ³ /h	2.63		3.14		
Propane Gas (L.P.G.)	kg/h				1.98	2.38
Gas injector diameter	mm	5.3		5.3	4.1	4.1
Central Heating						
Maximum rated heat input (net)	kW	24.64	13.29	24.64	24.64	24.64
Maximum rated heat output 40/30 °C	kW	25.23	13.86	25.23	25.23	25.23
Maximum rated heat output 50/30 °C	kW	24.76	13.58	24.76	24.76	24.76
Maximum rated heat output 80/60 °C	kW	24	13	24	24	24
Maximum flow temperature	°C	82	82	82	82	82
Maximum flow temperature possible	°C	86	86	86	86	86
Maximum permissible operating pressure	bar	2.5	2.5	2.5	2.5	2.5
Available pump head at 20 °C system temperature rise	m	2.0	2.0	2.0	2.0	2.0
Flue						
Flue gas temperature max. load DHW demand	°C	77	77/85	85	77	85
Flue gas temperature 80/60 °C, rated/min. load	°C	60/55	61/55	60/55	60/55	60/55
Flue gas temperature 40/30 °C, rated/min. load	°C	50/34	42/34	50/34	50/34	50/34
CO ₂ level at max. rated heat output (after 10 minutes)	%	9.8	9.8	9.8	11	11
CO ₂ level at min. rated heat output (after 10 minutes)	%	9.2	9.2	9.2	10.5	10.5
NOx class		5	5	5	5	5
NOx rating	mg/kWh	49	39	49	49	49
Condensate						
Maximum condensate rate	l/h	2.0	1.0	2.0	2.0	2.0
pH value, approx.		4.8	4.8	4.8	4.8	4.8
Electrical						
Electrical power supply voltage	a.c. V	230	230	230	230	230
Frequency	Hz	50	50	50	50	50
Maximum power consumption - running	W	110	110/127	127	111	130
Maximum power consumption - stand-by	W	1	1	1	1	1
Energy efficiency index (EEI) heating pump		≤ 0.23	≤ 0.23	≤ 0.23	≤ 0.23	≤ 0.23
General data						
HCM identification number		1410	1491/1492	1412	1411	1413
Expansion vessel charge	bar	0.75	0.75	0.75	0.75	0.75
Appliance protection rating	IP	IPX4D	IPX4D	IPX4D	IPX4D	IPX4D
Appliance protection rating with mechanical or RF mechanical timer or FW100 module fitted	IP	IP20	IP20	IP20	IP20	IP20
Appliance protection rating with Sense II control fitted	IP	IPX2D	IPX2D	IPX2D	IPX2D	IPX2D
Permissible ambient operating temperatures	°C	0 - 50	0 - 50	0 - 50	0 - 50	0 - 50
Nominal capacity of appliance	litre	3.9	3.9	3.9	3.9	3.9
Total packaged weight	kg	42	42	42	42	42
Lift weight (without front panel and expansion vessel)	kg	29	29	29	29	29
SEDBUK 2009	%	89.6	89.6	89.6	90.6	90.6

1) Greenstar i appliances are fitted with a flow regulator set to achieve a 40°C temperature rise. This ensures comfortable bathing during the colder winter months.

2) The Gas Rate provided assumes the accepted NG averaged calorific value of 34.9 MJ/m³ net.

3.3 Energy efficiency

The following product data satisfy the requirements of the EU Regulations No. 811/2013 and No. 812/2013 supplementing Directive 2010/30/EU.

Product data	Symbol	Unit	7733600012	7733600005	7733600031	7733600032
Product type	–	–	25i ^{ErP} NG	30i ^{ErP} NG	25i ^{ErP} LPG	30i ^{ErP} LPG
Condensing boiler	–	–	Yes	Yes	Yes	Yes
Low temperature boiler	–	–	No	No	No	No
B1 boiler	–	–	No	No	No	No
Cogeneration space heater (CHP)	–	–	No	No	No	No
Combination heater	–	–	Yes	Yes	Yes	Yes
Rated heat output	P _{rated}	kW	24	24	24	24
Seasonal space heating energy efficiency	η _s	%	94	94	94	94
Energy efficiency class	–	–	A	A	A	A
Useful heat output						
At rated heat output and high temperature regime ¹⁾	P ₄	kW	24	24	24	24
At 30 % of rated heat output and low temperature regime ²⁾	P ₁	kW	8.2	8.2	8.2	8.2
Useful efficiency						
At rated heat output and high temperature regime ¹⁾	η ₄	%	87.7	87.7	87.7	87.7
At 30 % of rated heat output and low temperature regime ²⁾	η ₁	%	99.4	99.4	99.4	99.4
Auxiliary electricity consumption						
At full load	e _{l,max}	kW	0.039	0.039	0.039	0.039
At part load	e _{l,min}	kW	0.014	0.014	0.015	0.015
In standby mode	P _{SB}	kW	0.002	0.002	0.002	0.002
Other items						
Standby heat loss	P _{stby}	kW	0.058	0.058	0.058	0.058
Ignition burner power consumption	P _{ign}	kW	0	0	0	0
Emissions of nitrogen oxides	NO _x	mg/kWh	44	44	44	44
Sound power level, indoors	L _{WA}	dB(A)	50	50	50	50
Additional data for combination heaters						
Declared load profile	–	–	XL	XL	XL	XL
Daily electricity consumption	Q _{elec}	kWh	0.138	0.138	0.132	0.132
Annual electricity consumption	AEC	kWh	30	30	29	29
Water heating energy efficiency	η _{wh}	%	84	84	85	85
Water heating energy efficiency class	–	–	A	A	A	A
Daily fuel consumption	Q _{fuel}	kWh	20.886	20.886	20.615	20.615
Annual fuel consumption	AFC	GJ	18	18	18	18

Table 4 Product data for energy efficiency in accordance with Regulation (EU) no. 813/2013

1) High temperature regime means 60 °C return temperature at heater inlet and 80 °C feed temperature at heater outlet.

2) Low temperature means for condensing boilers 30 °C, for low-temperature boilers 37 °C and for other heaters 50 °C return temperature (at heater inlet).

3.4 Layout

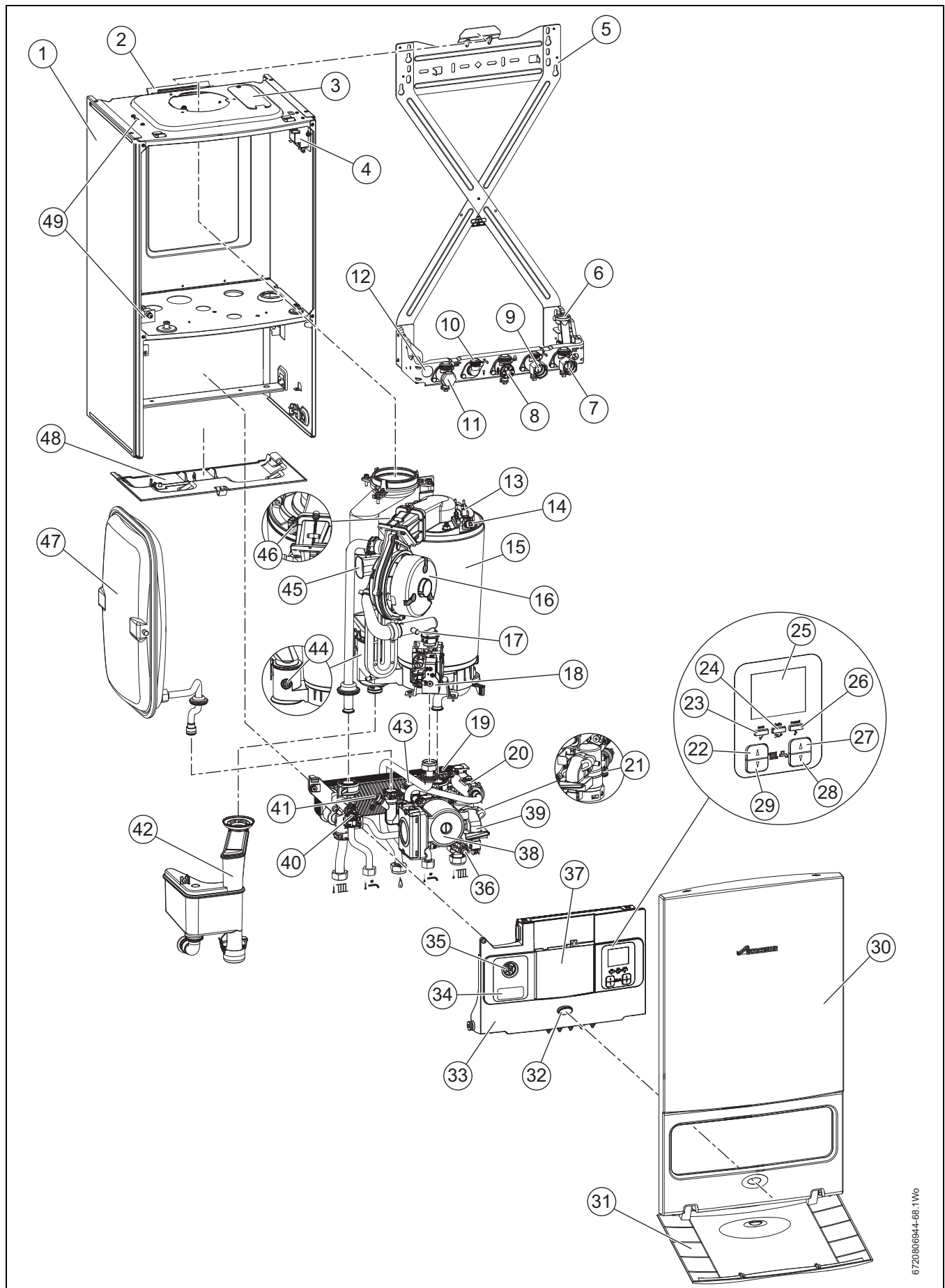

Fig. 2 Main appliance components

6720806944-68.1Wo

1	Main superstructure	26	Reset/Service engineer button
2	Hanging bracket	27	DHW settings increase button/Increase button (menu edit mode)
3	Removable panel - for servicing	28	DHW settings decrease button/Decrease button (menu edit mode)
4	Ignition transformer	29	CH settings decrease button
5	Wall mounting frame	30	Front panel
6	Pressure relief valve connector	31	Facia panel
7	CH return isolating valve	32	Operation/fault indicator light (blue)
8	Gas isolating valve	33	Control panel
9	DCW mains isolating valve	34	Appliance identification label
10	DHW outlet connection	35	Pressure gauge
11	CH flow isolating valve	36	Drain point
12	Condensate drain locator	37	Blank for optional programmer
13	Electrode assembly	38	Circulating pump
14	Overheat thermostat	39	Diverter valve stepper motor and protective cover
15	Heat exchanger	40	DHW temperature sensor (NTC)
16	Fan	41	Pressure gauge connection point
17	Fan pressure test point	42	Condensate siphon
18	Gas valve	43	Automatic air vent
19	DHW plate heat exchanger	44	Flue overheat thermostat
20	Flow turbine and flow regulator assembly	45	Combustion air inlet
21	Pressure relief valve	46	Flow temperature sensor (NTC)
22	CH settings increase button	47	Expansion vessel
23	ECO/OK button	48	Bottom panel (location for optional filling link key)
24	Info/Return/menu button	49	Expansion vessel supports (upper and lower combustion chamber)
25	Appliance display		

Table 5 Key to appliance components

Appliance features

- Aluminium-silicon heat exchanger, which has an extra-large surface area for enhanced heat exchanger efficiency.
- Low NOx emissions
- Fixed gas valve settings
- Direct burner ignition
- Zero pressure governor gas valve with fully modulating fan
- Display for appliance status and access to diagnostics, system and commissioning parameters
- Digital control system
- Memory retention after power interruption
- Low electrical power consumption during operation and stand-by modes
- Modulating pump
- Condensing in CH and DHW modes
- Three star Hot Water Comfort measured to EN13203 Part 1 in comfort mode with DHW pre-heat ON
- Eco mode, to use gas on demand
- Plate type DHW heat exchanger
- Ability to pre-plumb condensate drain, CH flow, DHW Outlet, Gas, DCW In, PRV and CH Return connections
- Large capacity siphonic condensate trap
- Galvanised steel wall mounting frame
- Standard wall frame provides vertical pipe route behind the appliance
- Compatible with all Worcester standard and intelligent controls
- Condensifit II flue systems 60/100 and 80/125 mm allows plume re-direction as standard and ability to attach plume management kits
- Front accessible components for service.

3.4.1 Electrical diagram

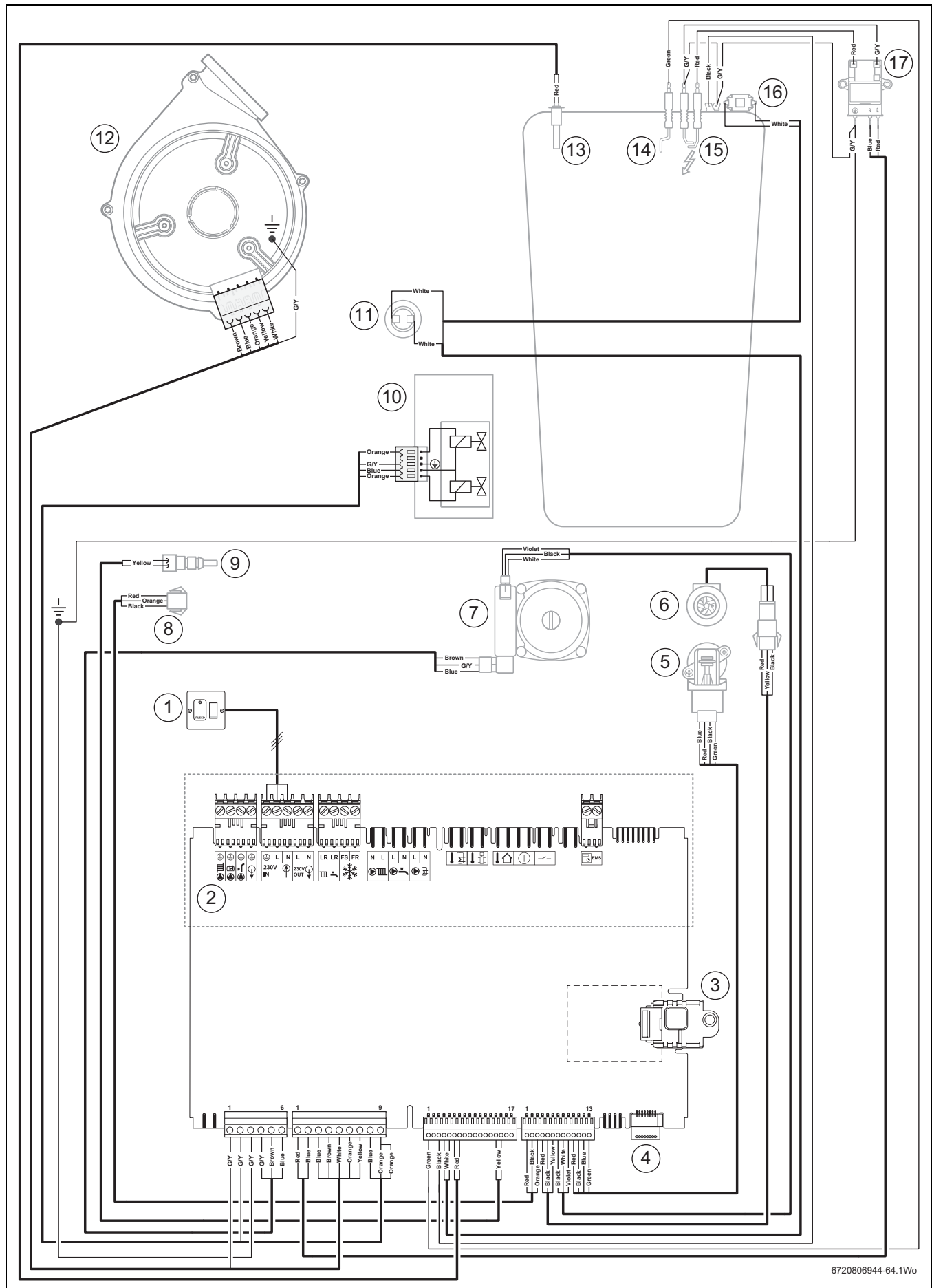

6720806944-64.1Wo

Fig. 3 Electrical diagram

Legend to figure 3:

- [1] Mains supply
- [2] Electrical connections
- [3] HCM
- [4] Ribbon cable to display screen
- [5] Diverter valve
- [6] Flow turbine
- [7] Circulating pump
- [8] NOT USED
- [9] Domestic Hot Water temperature sensor (NTC)
- [10] Gas valve
- [11] Flue overheat thermostat
- [12] Fan
230 Vac across brown & blue wires
- [13] Flow temperature sensor (NTC)
- [14] Flame sense electrode
- [15] Spark electrodes
- [16] Overheat thermostat
- [17] Spark generator



Resistance values

- ▶ Component resistance characteristics can be found in section 8.2, page 69.
 - Flow temperature NTC sensor
 - DHW NTC sensor
 - Flue overheat thermostat
 - Overheat thermostat
 - Outdoor weather compensation sensor
 - Gas valve

Connections/ symbol	Function
	1) Earth connections for: <ul style="list-style-type: none"> • CH circulation pump (NOT USED) • DHW charge pump (NOT USED) • DHW circulation pump (NOT USED) • 230V external controls
	230V supply to the appliance <ul style="list-style-type: none"> • Earth input • Live input • Neutral input
	230V feed to external controls <ul style="list-style-type: none"> • Live output • Neutral output
	Switch live (Live Return) to appliance <ul style="list-style-type: none"> • CH demand input • DHW demand input (pre-heat time control)
	External frost thermostat <ul style="list-style-type: none"> • FS output (Frost thermostat supply) • FR input (Frost thermostat return)
	DHW charge pump (NOT USED)
	DHW circulation pump (NOT USED)
	CH circulation pump (NOT USED)
	Cylinder sensor (NOT USED)
	Low Loss Header sensor (NOT USED)
	Outdoor weather compensation sensor (used when accessory outdoor sensor is connected)
	External cut off switch (NOT USED)
	Low voltage switch (NOT USED)
	2) External control system with EMS bus control (connection for Worcester intelligent wall mounted controls)

Table 6 Electrical connections

- 1) Green plug in connector pack found under installer connections cover.
- 2) Orange plug in connector pack found under installer connections cover.

4 Pre-installation

4.1 Cleaning primary systems



DANGER: Danger to life through electric shock!

- ▶ Before carrying out any work on electrical components, isolate them from the power supply (230 V AC) (fuse, circuit breaker) and secure against unintentional reconnection.



NOTICE: Risk of damage to appliance or accessories!

- ▶ All the following pre-installation sections must be read and requirements met before starting the appliance or flue installations.



NOTICE: Risk of damage to system or appliance!

Debris from the system can damage the appliance and reduce efficiency. Failure to comply with the guidelines for the use of water treatment with the appliance will invalidate the appliance guarantee and contravene the Building Regulations.

- ▶ It is a requirement of the Building Services Compliance Guide which is a second tier document to the Building Regulations to flush and inhibit the primary water system in accordance with BS 7593.
- ▶ It is recommended that you fit a primary water cleanser to the system. Worcester recommends fitting a filter that will help remove both magnetite and non-magnetic debris.

Before cleaning the system:

- ▶ Ensure that the system and pipe work is in good working order.
- ▶ **Where possible keep the existing appliance/circulating pump in place when flushing the system.**

Follow the guidance of BS7593:

Treatment of water in domestic hot water central heating and also the flushing guidelines below.



NOTICE: Artificially softened water must not be used to fill the central heating system.

- ▶ Do not use artificially softened water to fill the central heating system.

Flushing the system

- ▶ Fill the system with cold water and check for leaks.
- ▶ Open all drain cocks and drain the system.
- ▶ Close drain cocks and add a suitable flushing agent **compatible with aluminium** at the correct strength for the system conditions in accordance with the manufacturer's instructions.
The pH value of the system water must be less than 8 or the appliance guarantee will be invalidated.
- ▶ Circulate the flushing agent before the appliance is fired up.
- ▶ Run the appliance/system at normal operating temperature as directed by the manufacturer of the flushing agent.
- ▶ Drain and thoroughly flush the system to remove the flushing agent and debris.
- ▶ It may be necessary to use a power flushing machine to aid the cleansing procedure in some circumstances.
- ▶ Close the drain cocks and refill with fresh water and a suitable inhibitor.
- ▶ Vent any air from the appliance and system.

Inhibitor

Add a suitable inhibitor or combined inhibitor/anti-freeze, if the system is exposed to freezing conditions, to the heating system in accordance with the DWTa code of practice and manufacturer's guidelines.



WARNING: Sealing agents

Normally the addition of sealing agents to the system water is not permitted as this can cause problems with deposits left in the heat exchanger.

- ▶ In cases where all attempts to find a micro leak have failed, Worcester, Bosch Group supports the use of Fernox F4 leak sealer.

Water treatment products

Suitable water treatment products can be obtained from the following manufacturers:

ADEY	01242546717 or www.adey.com
FERNOX	0870 601 5000 or www.fernox.com
SENTINEL	0800 389 4670 or www.sentinel-solutions.net

Artificially softened water

It is possible to have an ion exchange water softener fitted to the cold water system of the property. However, the appliance requires an untreated cold water connection taken from the mains supply, before the water softener, to the primary water filling point of the heating system.

4.2 Mains supply

4.2.1 Electrical supply

- Supply: 230V - 50 Hz
- Cable: PVC insulated 0.75mm² (24 x 0.2mm) temperature rated to 90 °C.
- External 3A fuse to BS1362.
- The appliance must be earthed.
- This appliance must not be connected to a 3 phase supply.
- IPX4D.



NOTICE: IP rating change

IP rating IPX4D is reduced to IP20 if the following controls are fitted;
MT10, 7 716 192 036 or MT10RF, 7 716 192 037
or FR100 7 716 192 067.

This is reduced to IPX2D when the Sense II 7 738 111 064 is fitted.

- Wiring must comply with the latest edition of BS 7671 (IET wiring regulations).

4.2.2 Gas supply

- Appliances using Natural Gas (NG) must be connected to a governed meter.
- Liquid Petroleum Gas (LPG) must be connected to a regulator.
- Installation and connection of the gas supply to the appliance must be in accordance with BS6891.
- Gas pipe sizing should be calculated to ensure no more than the permitted mbar drop between the meter/governor to the appliance inlet. (→ Commissioning section).
- The meter or regulator and pipe work to the meter must be checked, preferably by the gas supplier.
This is to ensure that the equipment is in good working order and can meet the gas flow and pressure requirements, in addition to the demand from any other appliance being served.

4.2.3 Water supply

Use in hard water areas

Normally there is no need for water treatment to prevent scale formation as the maximum temperature of the DHW heat exchanger is limited by the electronic control.

In areas where temporary water hardness exceeds 200 ppm, consideration may need to be given to the fitting of a scale prevention device. In such circumstances, the advice of the local water authority should be sought.

Water mains pressure

- Minimum mains water pressure for maximum performance: refer to the Technical data in section 3.2.
- Maximum mains fed water pressure 10 bar.
 - If necessary fit a pressure reducing valve.



NOTICE: Risk of damage to household appliances! Non return, back flow prevention devices (including those associated with water meters) fitted to the mains water supply can cause a pressure build up which could damage the appliance and other household appliances.

- ▶ Fit a mini expansion between the non return valve, back flow prevention device.

- Where the mains water supply has a non-return, back flow prevention valve fitted, a mini expansion vessel [1] should be connected to the mains water inlet pipe [2] between the non-return valve [3] and the appliance [4] as shown below.

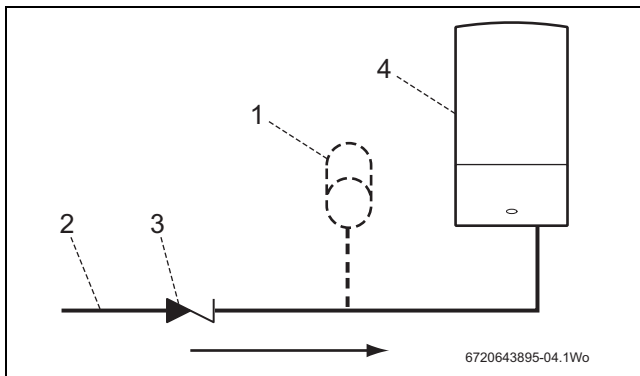

Fig. 4 Mini expansion vessel location

1	Mini expansion vessel - part no. 7 716 192 105
2	Mains water inlet pipe
3	Non return valve
4	Appliance

Table 7

4.3 Water systems and pipe work

Plastic pipework:

- Any plastic pipe work must have a polymeric barrier with 600mm (minimum) length of copper pipe connected to the appliance.
- Plastic pipe work used for underfloor heating must be correctly controlled with a thermostatic blending valve limiting the temperature of the circuits to approximately 50 °C.

Primary systems connections/valves:

- All system connections, taps and mixing valves must be capable of sustaining a pressure up to 3 bar.
- Radiator valves should conform to BS2767:10.
- All other valves should conform to BS1010.
- Thermostatic radiator valves (TRV's) must be used on all radiators within the sleeping accommodation but not the radiator where the room thermostat is sited. This must be fitted with lock-shield valves and left open.
- A drain cock is required at the lowest point in the system.
- An air vent is required at all the high points in the system.



NOTICE: To prevent reverse circulation

- ▶ The cylinder return must be the last connection on the common return pipe.



The appliance is equipped with an internal by-pass. The internal bypass is not intended to be a substitute for an external system bypass. An external automatic bypass should be used if the system flow can be significantly adjusted or stopped by zone valves and thermostatic radiator valves (TRV).

Showers/bidets:

- Ensure that the shower is suitable for use with mains water pressure.
- If a shower head can be immersed in water or comes closer than 25mm from the top edge of a bath or shower tray spill over level then an anti-siphon device must be fitted to the shower hose.
- Bidets with direct hot and cold mains water can be used (with the approval of the local water authority) and must be the over rim flushing type with shrouded outlets to prevent the fitting of hand held sprays.

Sealed primary system:

Refer to figures 6 and 7 on page 16.



NOTICE: Artificially softened water must not be used to fill the central heating system.

- ▶ Do not use artificially softened water to fill the central heating system.

- The CH sealed system must be filled using a WRAS approved filling loop or comply with figure 5 for system fill, for Worcester filling loops kit see section 4.7.
- Where the system volume is more than 100 litres or exceeds 2.65 bar at maximum heating temperature, an extra expansion vessel [2] (figures 6 & 7) must be fitted as close as possible to the appliance in the central heating return.
- Pressurise the extra expansion vessel [2] (figures 6 & 7) to the same figure as the expansion vessel built into the appliance.
- **Do not use galvanised pipes or radiators.**

System fill

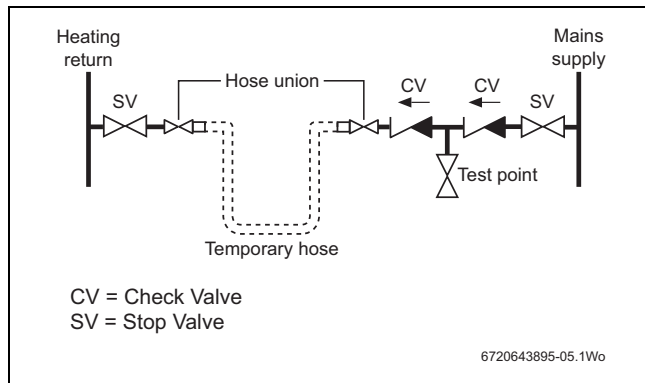

Fig. 5 System fill

i An optional filling loop and keyless version are available to fill the system (not supplied with the appliance).

Typical sealed system example

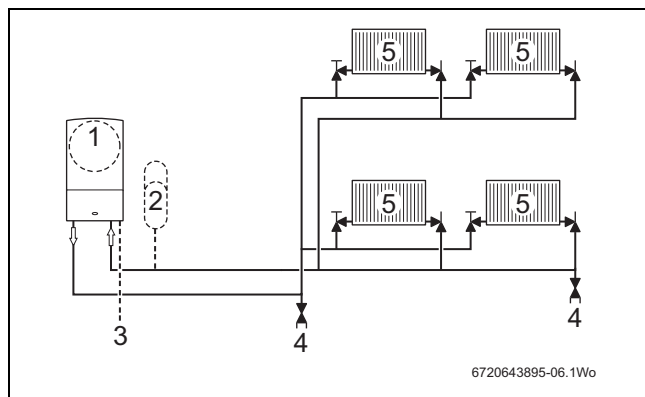

Fig. 6 Sealed system example

Sealed system with zone valves example

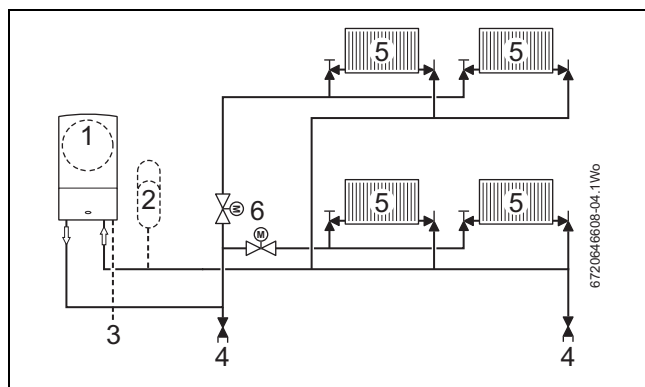

Fig. 7 Sealed system zone valves example

1	Appliance expansion vessel - CH
2	Extra expansion vessel - CH return
3	Pressure relief discharge
4	Drain cock
5	Radiators
6	Zone valves

Table 8 Key to fig. 6 & 7

4.3.1 Available pump head

i In order to save as much energy as possible and the minimise the possibility of water circulation noise, a low characteristic should be chosen.

The pump map can be selected within 2.1C in the Boiler settings menu list: (→ 6.5.13, page 43).

- **0** (pump variable speed setting)
- **1** (constant pressure low)
- **2** (constant pressure low/middle)
- **3** (constant pressure middle/high)
- **4** (constant pressure high)

The factory setting is:

4 (constant pressure high)

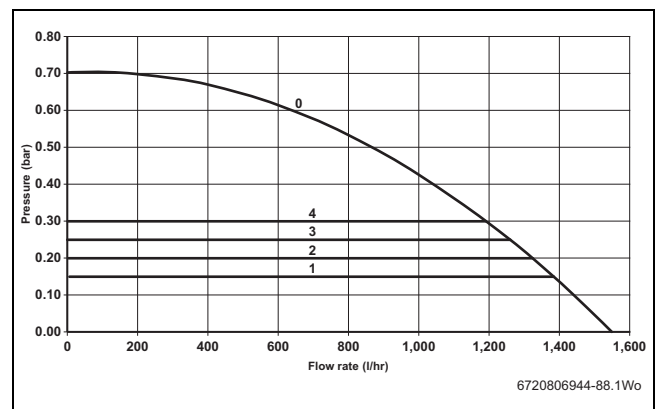

Fig. 8 Pump curve

Constant pressure head

If the constant pressure head option (1 - 4) is chosen, the differential pressure between the CH flow and return will be kept at the corresponding value. When the CH system is cold and the radiator TRVs are fully open, the pump will be running faster to try and maintain the pressure differential. When the TRVs start to close and the resistance of the CH system increases, the pump speed reduces to maintain the pressure.

The setting (1 - 4) to be selected is dependent upon the resistance and heat load of the CH system. The higher these are, the higher the pressure constant.

4.4 Appliance location and clearances

4.4.1 Installation

This appliance is only suitable for installing internally within a property at a suitable location onto a fixed, rigid surface at least the same size as the appliance and capable of supporting the appliance weight.

i No surface protection is required against heat transfer from the appliance.

The appliance must be installed where:

- An engineer can gain clear and safe access to work on the product or component, including making adequate provision for visual inspection of flues in voids.
- The homeowner can gain clear and safe access to the controls, check, top up or reset the appliance.
- Products in loft cavities must have permanent fixed lighting, a permanent fixed retractable ladder and a fixed floor area sufficient to allow access for normal use and servicing directly under and around the product and between and the access hatch.

4.4.2 Installation and servicing clearances

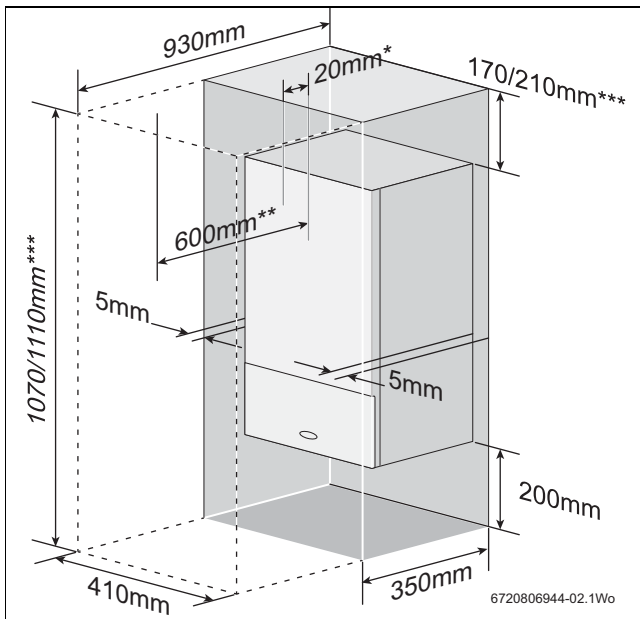

Fig. 9 Unventilated compartment

- [*] Minimum clearance to removable door
- [**] Minimum clearance required for servicing
- [***] Height for either 60/100 flue or 80/125 flue

4.4.3 Compartments

Follow the requirements of BS6798 and BS5440 Part 2 and note:

- Minimum clearances must be maintained.
- An access door is required to install, service and maintain the appliance and any ancillary equipment.
- If the boiler is installed in an unventilated airing/storage cupboard, there is no requirement to make a partition between the boiler and the storage space as long as the minimum clearances around the boiler are maintained.

4.4.4 Rooms containing a bath or shower

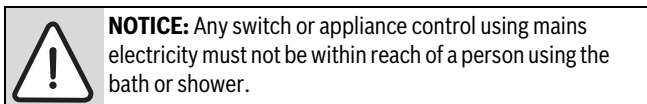

The installation **must be in accordance with the latest edition of the IET Wiring Regulations BS7671.**

Check the IP rating of any control units to be used on this appliance.
An appliance fitted with a blanking panel or control unit rated to IPX4D can be installed in zone 2.
An appliance fitted with a control unit rated below IPX4D must be installed outside zone 2.
Circuit breaking devices should be used in accordance with the regulations.

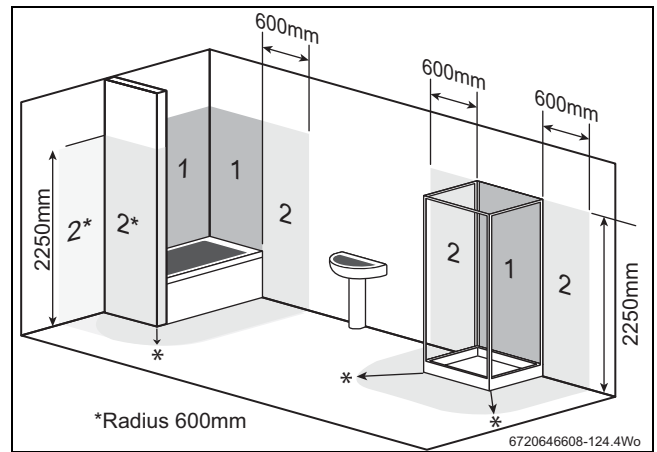

Fig. 10 Bathroom installations

[2*] Without the end wall, zone 2 must extend 600mm from the bath

4.5 Pressure relief pipe work

WARNING: Risk of scalding!
Injury if discharge pipe is not routed correctly.

- ▶ The pressure relief valve is a safety device for the appliance and if activated may discharge boiling water or steam through the relief valve drain pipe.
- ▶ Care should be taken when siting the outlet pipe so that it does not cause an obstruction or discharge above a window, entrance or other public access where it could cause a hazard.

- The pressure relief drain pipe [1] and [3] from the appliance should be at least 15mm diameter copper pipe and run downwards to a safe point of discharge, away from any electrical equipment or other hazard, preferably to an external drain or soak away.
- Pipe [1] should be finished with a partial bend, near the outlet to face the external wall (as shown) to help prevent freezing.

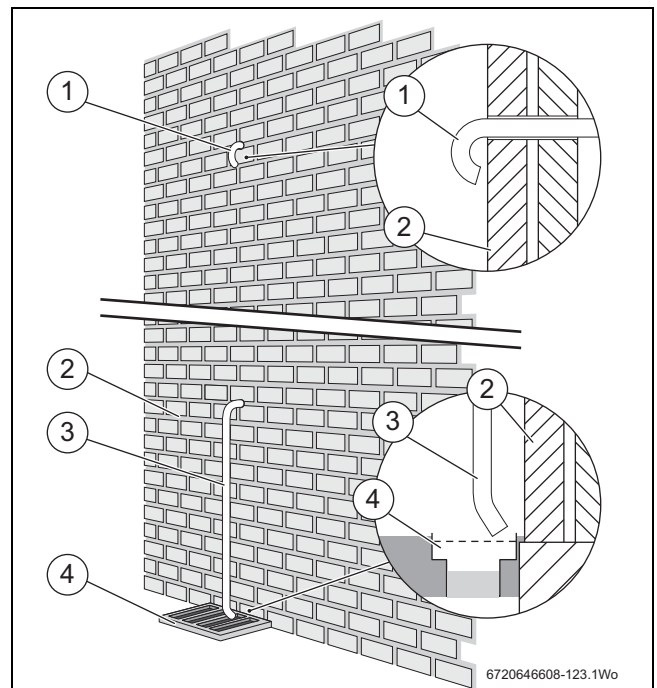

Fig. 11 Pressure relief pipe work

- [1] Outlet facing external wall
- [2] External wall
- [3] Outlet to external drain
- [4] External drain

4.6 Condensate discharge

For correct installation and trouble free operation of the appliance the following advice should be followed:

1. All condensate pipework must 'fall' from the appliance by a minimum of 3 degrees (52mm per metre) to ensure adequate condensate flow.
2. The pipework route must allow air to be supplied back to the appliance for correct operation of the siphon.
3. Connection to a rainwater down pipe must include an air break.



More information is available in **BS.6798:2014**
'Specification for selection, installation, inspection, commissioning, servicing and maintenance of gas-fired boilers of rated input not exceeding 70 kW net'

Also:

- Keep external pipework as short as possible and not exceed 3 metres length.
- External pipework should be increased to a minimum diameter of 32mm and ideally be insulated.
- Minimise the number of bends and connectors.
- Remove burrs after cutting pipe.
- Remove surplus solvent from the interior of the pipe.

4.6.1 Appliance siphonic condensate trap

The appliance has a large capacity condensate trap reducing the risk of condensate discharge freezing up in prolonged cold temperatures.

Like the CondenseSure siphon accessory, the expanded siphonic operation discharges every 15 to 20 minutes. Resulting in:

- Increased velocity and flow rate.
- With only 3 to 4 siphonic actions per hour, the condensate pipework is empty for longer.
- Eliminated freezing potential for a 48 hour period at -15 °C, provided the installation parameters listed below are followed.

4.6.2 Condensate pipe work



NOTICE:

- ▶ Where a new or replacement boiler is being installed, access to an internal "gravity discharge" point should be one of the factors considered in determining boiler location.
- ▶ The condensate pipe must be nominally 22mm Ø plastic pipe.
- ▶ The condensate pipe work must fall at least 52mm per metre towards the outlet and should take the shortest practicable route.
- ▶ Ensure there are no blockages in the pipe run.



NOTICE: Unheated internal areas.

Although the large volume siphon will reduce the risk of freezing, condensate discharge may freeze in areas of prolonged cold temperatures.

- ▶ Internal pipe runs in unheated areas such as lofts, basements and garages should be treated as external runs.

Key to condensate illustrations, figures 12, 13, 14 & 15

1	Condensate discharge from boiler
2	Soil and vent stack
3	Minimum 450mm and up to three storeys
4	Visible air break at plug hole
5	Sink or basin with integrated overflow
6	75mm sink waste trap
7	Condensate pump

Table 9 Key to Internal condensate disposal methods

4.6.3 Internal connections

In order to minimise risk of freezing during prolonged cold spells, the following methods of installing condensate drainage pipe should be adopted, in order of priority.

Wherever possible, the condensate drainage pipe should be routed and terminated so that the condensate drains away from the boiler under gravity to a suitable internal foul water discharge point such as an internal soil and vent stack. A suitable permanent connection to the foul waste pipe should be used.

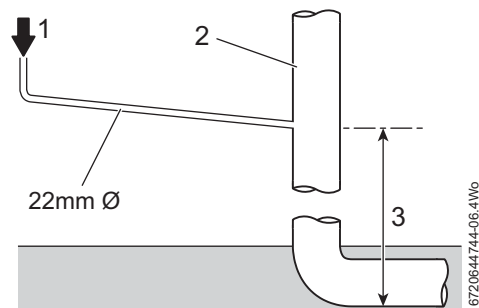

Fig. 12 Disposal to soil vent stack

Alternatively if the first option is not possible an internal kitchen, bathroom or washing machine waste pipe etc. can be used.

Ensure that the condensate drain pipe is connected "down stream" of the waste trap.

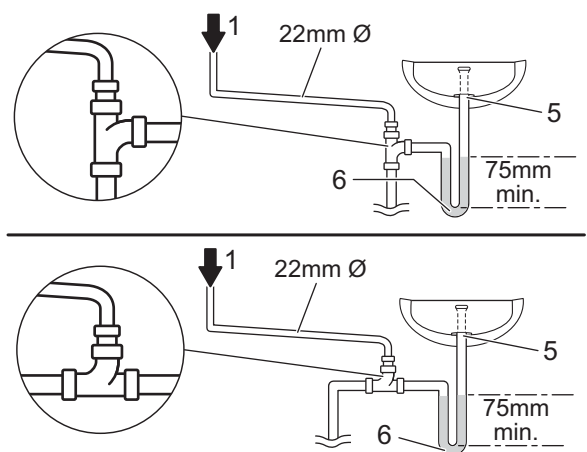

Fig. 13 Disposal to a waste pipe

CONDENSATE PUMP

Where "gravity discharge" to an internal termination is not physically possible, or where very long internal runs would be required to reach a suitable discharge point, condensate should be removed using a proprietary condensate pump, of a specification recommended by the boiler or condensate pump manufacturer.

The pump outlet pipe should discharge to a suitable internal foul water discharge point such as an internal soil and vent stack or if not possible to internal kitchen, bathroom or washing machine waste pipe etc. A suitable permanent connection to the foul waste pipe should be used.

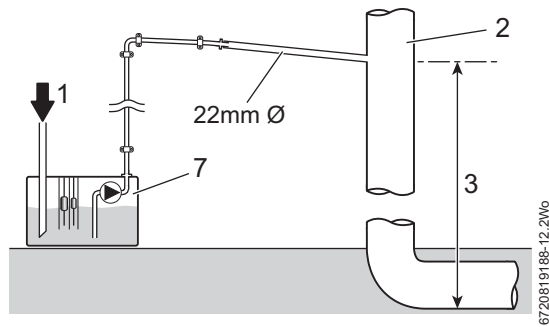

Fig. 14 Condensate pump disposal

4.6.4 External connections

NOTICE: Rainwater or external drain disposal
Untreated condensate must not be allowed to flow into streams or rivers

- ▶ A rainwater down pipe or an external drain shall only be used for condensate disposal if the down pipe or external drain is connected to a combined foul and rainwater system
- ▶ Refer to BS 6798 for more information

NOTICE: Grey water systems
Contamination of recovered water

- ▶ Condensate disposal shall not be allowed into a grey water recovery system that is intended for re-use

NOTICE: Freezing conditions

- ▶ Pipe work length should be kept to a minimum and the route as vertical as possible.
- ▶ When required, use only weather proof insulation.

NOTICE: Condensate waste

- ▶ Care should be taken when siting a soak-away to avoid obstructing existing services.

Continued - Key to condensate illustrations, figures 16, 17, 18& 19

8	45° Connector
9	100mm Ø minimum plastic pipe
10	Drainage holes
11	Limestone chippings
12	Bottom of sealed tube
13	Insulate and increase pipe size
14	Pipe work transition
15	External air break
16	Air gap
17	External rain water pipe into foul water
18	45° Bend

Table 10 Key to external condensate disposal methods

i Condensate drainage pipe can be run above or below ground. If the pipe work is run under ground, care must be taken to ensure that the pipe work “fall” towards the disposal point is maintained

If no other discharge method is possible then the use of an externally run condensate drainage pipe terminating at a suitable foul water discharge point, or purpose-designed soak away, may be considered. If this method is chosen then the following measures should be adopted:

- ▶ Use a CondenseSure siphon to help prevent the condensate freezing.
- ▶ The external run be kept as short as possible and not exceed 3 metres.

- ▶ The pipe should be run internally as far as possible before going externally and the pipe diameter should be increased to 32mm before it passes through the wall to the exterior. The pipe should be insulated using suitable waterproof and weather resistant insulation, if not using a CondenseSure siphon.
- ▶ The external pipe should take the shortest and least exposed route to the discharge point, and should “fall” as steeply as possible away from the boiler, with no horizontal runs in which condensate might stand.
- ▶ The use of fittings, elbows etc. should be kept to a minimum and any internal “burrs” on cut pipe work should be removed so that the internal pipe section is as smooth as possible.

FITTING AN EXTERNAL AIR BREAK

- Refer to figure 15 when a rain water down pipe is used to dispose of condensate.
- An air break must be installed in the 43mm pipe work, between the boiler condensate outlet and the drainpipe, outside the property, to avoid flooding during adverse weather conditions.

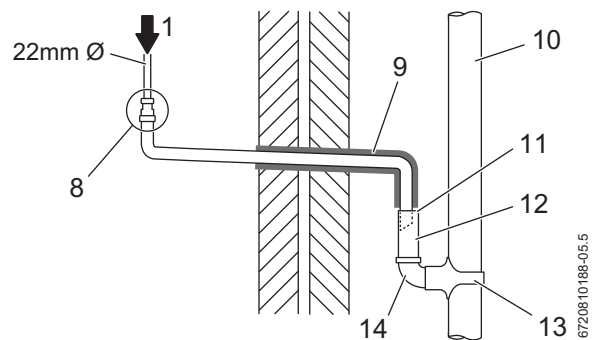

Fig. 15 Disposal into a rainwater down pipe

Where the pipe terminates over an open drain or gully, the pipe should terminate below the grating level, but above water level, in order to minimise “wind chill” at the open end.

The use of a drain cover (such as those used to prevent blockage by leaves) may offer further protection from wind chill.

Pipe drainage will be improved if the end is cut at 45° as opposed to a straight cut.

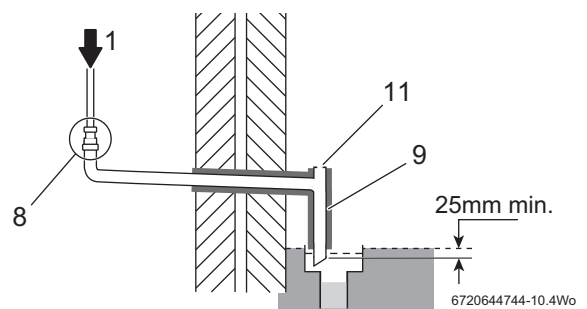

Fig. 16 External disposal

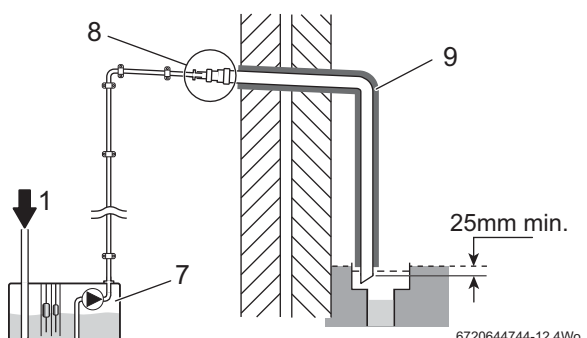

Fig. 17 Condensate pump to external disposal

CONDENSATE SOAK AWAY

- The condensate drainage pipe may be run above or below the ground to the soak away. The examples shown on this page run above ground.
- The soak away must use a 100mm Ø plastic tube with two rows of three 12mm holes on 25mm centres and 50mm from the bottom of the tube. The holes must face away from the house.
- The tube must be surrounded by at least 100mm of limestone chippings to a depth of 400mm.



Minimum hole size for the condensate soak away must be 400mm deep by 300mmØ.

In situations where there are likely to be extremes of temperature or exposure, the use of a proprietary trace-heating system for external pipe work, incorporating an external frost thermostat, should be considered. If such a system is used, the requirement to use 32mm pipe does not apply. However, all other guidance above and the instructions for the trace heating system, should be closely followed.



NOTICE: Unheated internal areas.

- ▶ Internal pipe runs in unheated areas such as lofts, basements and garages should be treated as external runs and consideration should be given to using a CondenseSure siphon.

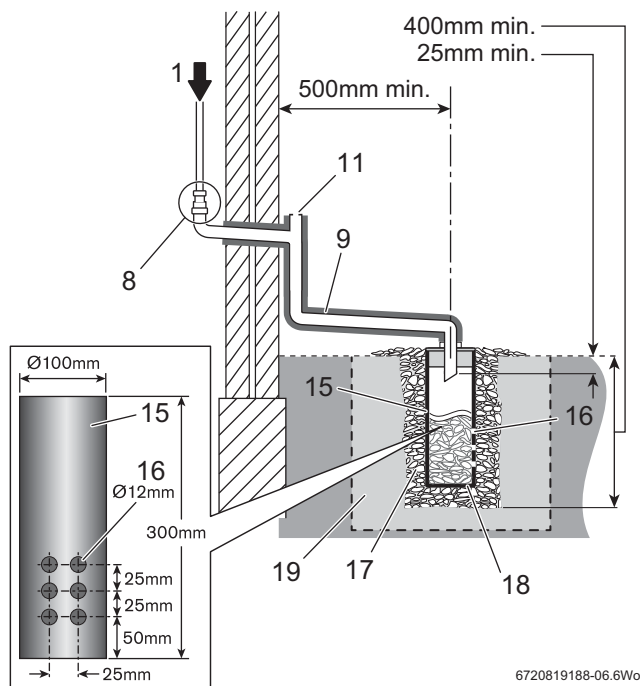

Fig. 18 To a soakaway

4.7 Standard accessories

Appliance accessories

Part number	Description
7 716 192 713	Vertical pre-piping assembly
7 716 192 609	Greenstar System filter
7 716 192 281	Filling link kit (key included)
7 716 192 610	Keyless filling link kit
7 716 192 686	Earth bonding strip
7 733 600 091	Heat exchanger cleaning kit

Table 11 Appliance accessories

Plug-in programmer/timers accessories

The programmers/timers listed can be used with the appliances stated on the front of this manual.

Part number	Description
7 716 192 036	MT10 mechanical timer
7 716 192 037	MT10RF mechanical thermostat
7 716 192 038	DT20 twin channel digital timer (preheat time control available)
7 716 192 054	DT20RF digital RF thermostat with twin channel programmer (preheat time control available)
7 716 192 052	DT10RF digistat (preheat time control available)
7 716 192 053	DT10RF optimiser (preheat time control available)
7 716 192 065	FR10 intelligent room thermostat
7 716 192 066	FR110 programmable room thermostat (preheat time control available)
7 716 192 067	FW100 weather compensation controller (preheat time control available)
7 733 600 001	Comfort I RF (RF thermostat with twin channel programmer, preheat time control available)
7 733 600 002	Comfort II RF (programmable room thermostat, preheat time control available)
7 733 600 003	Comfort (twin channel programmer)
7 733 600 039	Comfort wall plate kit
7 738 110 058	Sense I intelligent room thermostat
7 738 111 064	Sense II weather compensation controller (preheat time control available)
7 716 192 072	Worcester Wave (thermostat)

Table 12 Control accessories

Basic weather compensation sensor

Outdoor weather sensor (to activate on-board simple Weather Compensation).

Part number	Description
7 716 192 764	Outdoor weather sensor

Table 13 Control accessories



The outdoor weather sensor is not required with the FR10, FR110, Comfort I RF, Comfort II RF and Worcester Wave.

4.8 Plumbing manifold

4.8.1 Connections



Further guidance on pipe routing can be found printed on the appliance template (supplied with the appliance).

- For further ease of fitting, an optional Vertical Pre-piping Assembly kit is available, comprising four pre-formed copper water pipes.

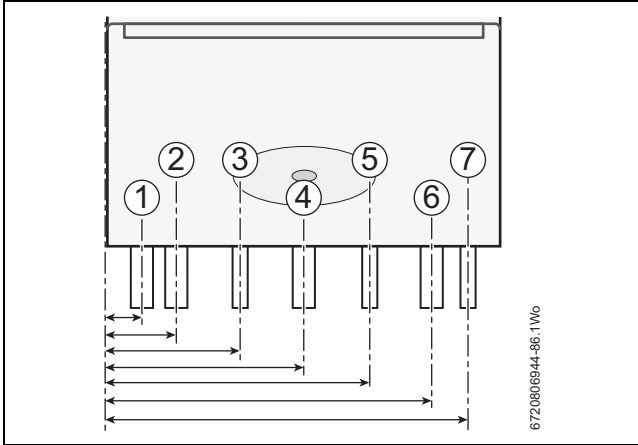

Fig. 19 Pipe dimensions

#	Function	From left case edge	Diameter of pipe
1	Condensate	38mm	22mm rubber push fit connector
2	CH Flow	70mm	22mm compression fitting
3	DHW Outlet	135mm	15mm compression fitting
4	Gas	200mm	22mm compression fittings
5	DCW Mains In	265mm	15mm compression fitting
6	CH Return	330mm	22mm compression fitting
7	Pressure Relief Valve	364mm	15mm (fittings not supplied)

Table 14 Key to figure 19

Use the fittings supplied in the Hardware literature pack.

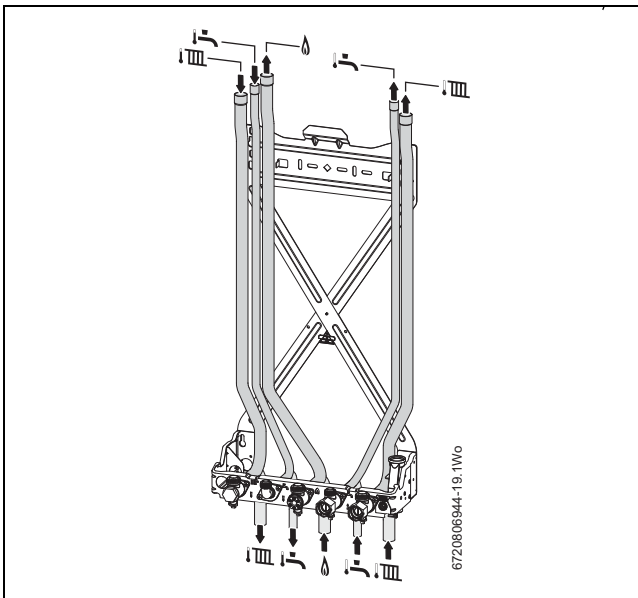

Fig. 20 Pipes within wall frame example

4.9 Flue options



CAUTION: Non accessible flue systems:

- Where a flue system is not going to be accessible, provision must be made for service and inspection.
- Voids containing concealed flues must have at least one inspection hatch no less than 300mm square.
- Flue joints within the void must not be more than 1.5 metres from the edge of the inspection hatch.
- Inspection hatches should be located at changes of direction.
- If this is not possible, bends should be viewable from both directions.



Refer to the manual supplied with the flue kit for complete installation instructions. Plume management kits are available for the 60/100 horizontal flue system.



Effective flue lengths:

- Each 90° bend used is equivalent to 2 metres of straight flue.
- Each 45° bend used is equivalent to 1 metres of straight flue.

Part number	Flue	Description
7 716 191 082	60/100	Telescopic horizontal flue assembly
7 716 191 171	60/100	Longer telescopic horizontal flue assembly
7 733 600 048	60/100	Horizontal high level telescopic flue kit
7 719 003 702	80/125	Telescopic horizontal flue assembly
7 719 002 430	60/100	Vertical flue assembly
7 719 002 431	80/125	Vertical flue assembly

Table 15 Flue kit part numbers

4.9.1 Flue lengths

The flue systems have different maximum flue lengths

The Greenstar series has the option of two horizontal 60/100 RSF (telescopic and longer telescopic) and one horizontal 80/125 RSF (telescopic) flue system and two vertical RSF (60/100 or 80/125) flue systems:

Refer to the following example Flue options for the maximum flue lengths.



Horizontal high level flue assembly

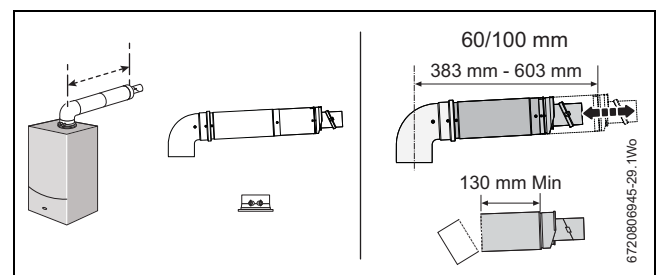

	Flue length (mm)	
	60/100	80/125
Horizontal high level telescopic flue assembly	202 - 603	N/A

Table 16

Telescopic horizontal flue assembly

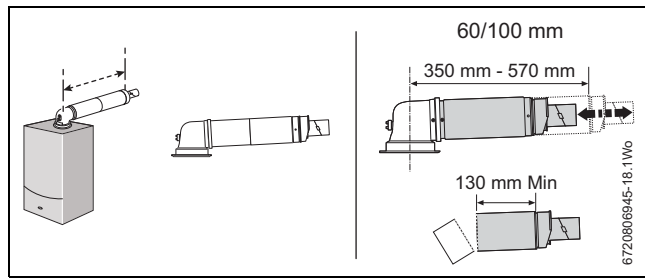

	Flue length (mm)	
	60/100	80/125
Telescopic horizontal flue assembly	180 - 570	405 - 600
Longer telescopic horizontal flue assembly	570 - 790	N/A

Table 17

Extended horizontal flue

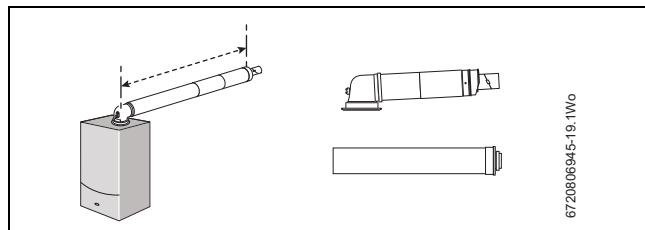

	Maximum flue length (mm)	
	60/100	80/125
Extended horizontal flue	4,600	13,000

Table 18

Horizontal flue with additional elbow (1 x 90° bend)

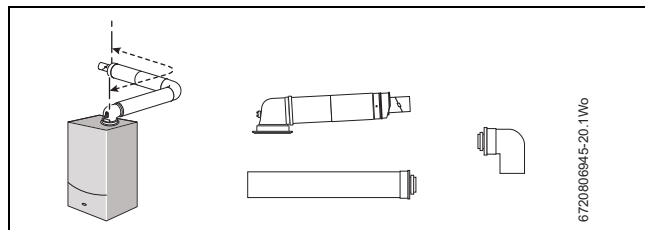

	Maximum flue length (mm)	
	60/100	80/125
Horizontal flue with 1 x 90° bend	2,600	11,000

Table 19

Horizontal flue with additional elbows (2 x 90° bends)

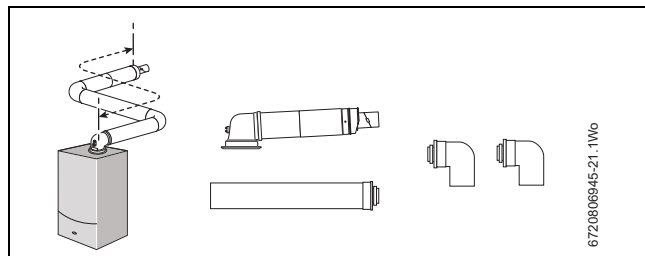

	Maximum flue length (mm)	
	60/100	80/125
Horizontal flue with 2 x 90° bends	N/A	9,000

Table 20

High level horizontal flue

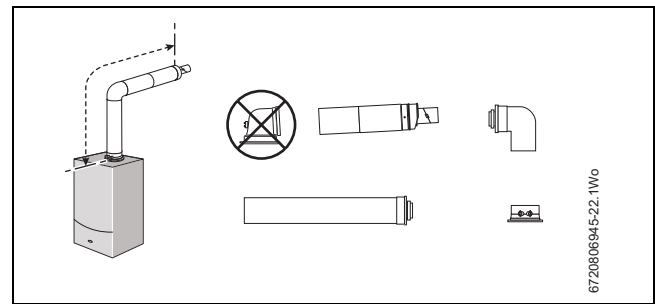

	Maximum flue length (mm)	
	60/100	80/125
High level horizontal flue	4,600	13,000

Table 21

High level horizontal flue with additional elbows

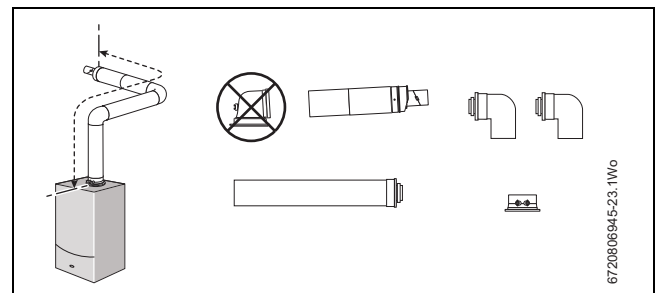

	Maximum flue length (mm)	
	60/100	80/125
High level horizontal flue with 2 x 90° bends	2,600	11,000

Table 22

High level horizontal flue with additional elbows

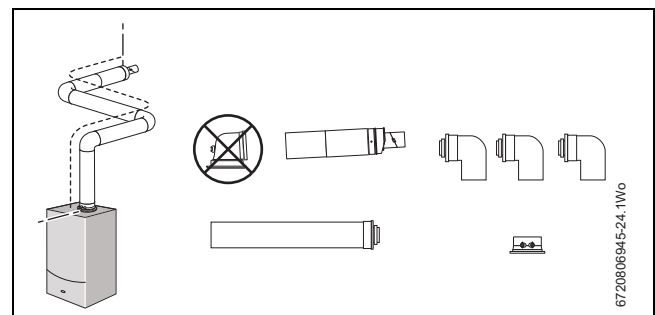

	Maximum flue length (mm)	
	60/100	80/125
High level horizontal flue with 3 x 90° bends	N/A	9,000

Table 23

Vertical balanced flue assembly

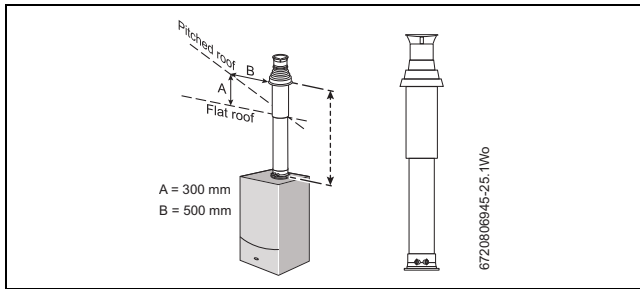

	Maximum flue length (mm)	
	60/100	80/125
Vertical balanced flue assembly	6,400	15,000

Table 24

Vertical balanced flue with elbow offset (2 x 90° bends)

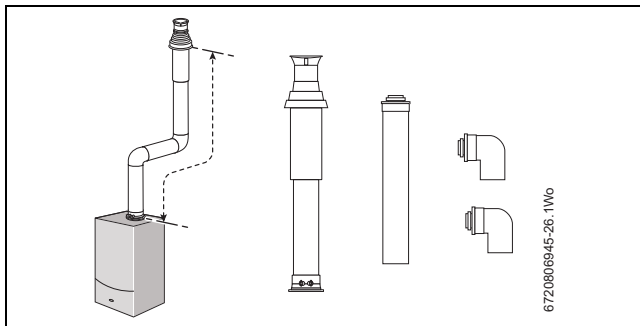

	Maximum flue length (mm)	
	60/100	80/125
Vertical balanced flue with 2 x 90° bends	2,400	11,000

Table 25

Vertical balanced flue with elbow offset (2 x 45° bends)

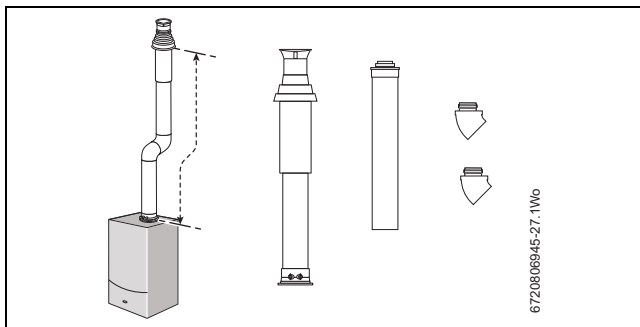

	Maximum flue length (mm)	
	60/100	80/125
Vertical balanced flue with 2 x 45° bends	4,400	13,000

Table 26

4.9.2 Determine the plume management system length



Note: Measurement M plume length

- ▶ M must be a minimum of 500mm and must not exceed 4,500mm for a 60mm plume management system used with the horizontal Ø 60/100mm flue.

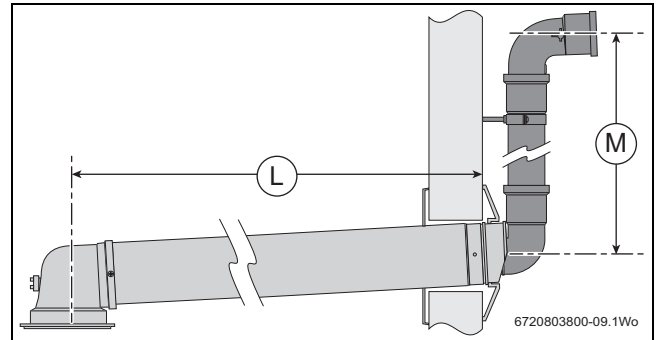

Fig. 21 Effective lengths L and M

Minimum plume management length

The minimum plume length should be calculated to ensure that the air inlet and exhaust have a minimum distance of 500mm between them (→ figure 22).

The plume management can be in any configuration, within the parameters of the plume management installation instructions, as long as it does not terminate inside the shaded area.



WARNING: Minimum plume management length.

The minimum distance of 500mm must be maintained between air inlet and exhaust.

- ▶ Do not terminate the plume management inside the shaded area shown in figure 22

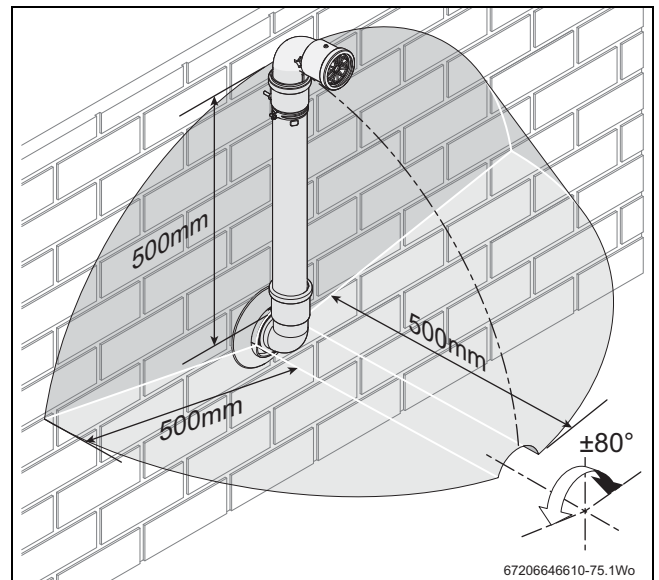

Fig. 22 Terminal exclusion zone



NOTICE: Cutting the 500mm pipe

If the 500mm plume management pipe kit is cut, an additional elbow will be required to join the pipework.

- ▶ The Plume management extension kit contains the components required for such a configuration.

Maximum plume management length

The Greenstar i range appliances can use up to 4,500mm of plume management regardless of flue length.

4.10 Flue terminal positions

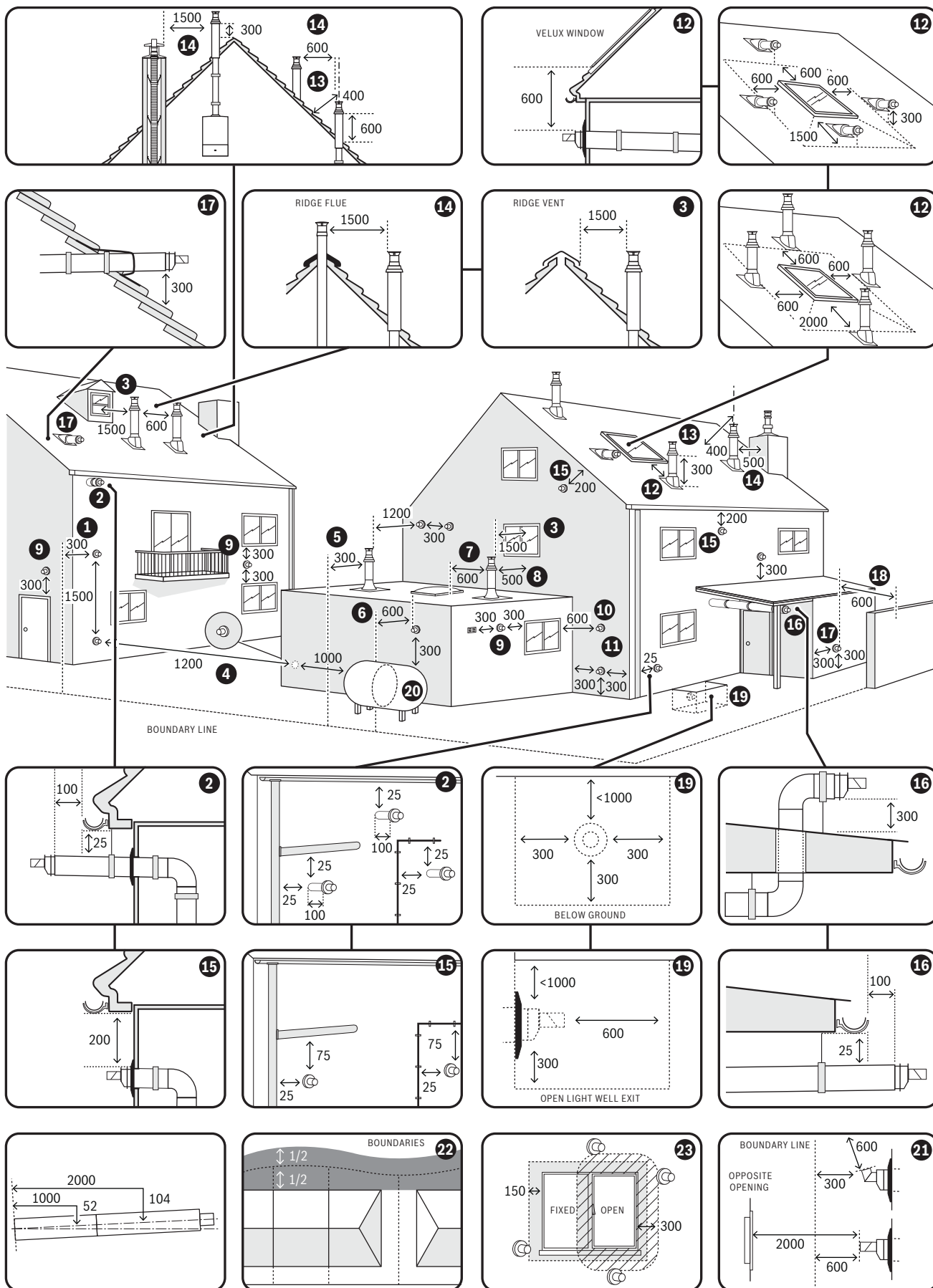

6720813276-20.1Wo

Fig. 23 Flue terminal positions



NOTICE:

- ▶ All measurements are the minimum clearances required.
- ▶ Terminals must be positioned so to avoid combustion products entering the building.
- ▶ Support the flue at approximately one metre intervals and at a change of direction, use suitable brackets and fittings:
 - flue bracket 100mm x 1 - part number: 7 716 191 177
 - flue bracket 100mm x 6 - part number: 7 716 191 178
 - flue bracket 125mm x 1 - part number: 7 716 191 179

Key to illustration

1. 300mm adjacent to a boundary line.
2. The dimension below eaves, gutters, pipes and drains can be reduced to 25mm, as long as the flue terminal is extended by 100mm past any overhang. External flue joints must be sealed with suitable silicon sealant.
3. 1,500mm between a vertical flue terminal and a window or dormer window.
4. 1,200mm between terminals facing each other.
5. Vertical flue clearance, 300mm adjacent to a boundary line unless it will cause a nuisance. BS 5440: Part 1 recommends that care is taken when siting terminal in relation to boundary lines.
6. 600mm distance to a boundary line, unless it will cause a nuisance. BS 5440: Part 1 recommends that care is taken when siting terminal in relation to boundary lines.
7. 600mm minimum clearance from a skylight to a vertical flue.
8. Vertical flue clearance, 500mm to non-combustible building material, and 1,500mm clearance to combustible building material.
9. 300mm above, below and either side of an opening door, air vent or opening window.
10. 600mm diagonally to an opening door, air vent or opening window.
11. 300mm to an internal or external corner.
12. 2,000mm below a Velux window for a vertical flue (1500mm for horizontal flue) 600mm above or to either side of the Velux window.
13. 400mm from a pitched roof or 500mm in regions with heavy snow fall.
14. 500mm clearance to any vertical structure on a roof, 600mm to room sealed flue or 1,500 to an open flue.
15. 200mm below eaves and 75mm below gutters, pipe and drains.
16. The dimension below eaves, balconies and car ports can be reduced to 25mm, as long as the flue terminal is extended by 100mm past any overhang. External flue joints must be sealed with suitable silicon sealant.
17. Flue clearance must be at least 300mm from the ground. Terminal guards must be fitted if the flue is less than 2 metres from the ground or if a person could come into contact with the flue terminal.
18. 600mm distance to a surface facing a terminal, unless it will cause a nuisance. BS 5440: Part 1 recommends that care is taken when siting terminals in relation to surfaces facing a terminal.
19. Below ground level in an open lightwell. The flue must be at least 600mm from the opposing surface and have at least 300mm clearance either side and below. The flue terminal must be no more than 1000mm from the top of the lightwell.
20. Flues should clear any LPG storage by 1,000mm horizontally and 300mm above.
21. Where the flow of products of combustion is not at right angles to the boundary, the 600mm dimension may be measured in the direction of flow as long as the terminal is not less than 300mm from the boundary.
22. For the purpose of determining suitable flue terminal positions for gas appliances, the boundary can be considered to extend to the centre line of any adjacent routes or waterways e.g. paths, streets, rights of way, canals, rivers or railways.

23. 300mm from an opening or vented window, 150mm to a fixed unvented window.



Note:

- ▶ Installations in car ports are not recommended.
- ▶ The flue cannot be lower than 1,000mm from the top of a light well due to the build up of combustion products.
- ▶ Dimensions from a flue terminal to a fanned air inlet to be determined by the ventilation equipment manufacturer.
- ▶ A flue terminal guard should be fitted over a terminal, if persons could come into contact with the terminal, or it could be subject to damage and where the terminal is less than 2,000mm from the finished floor level.

4.11 Plume management terminal positions

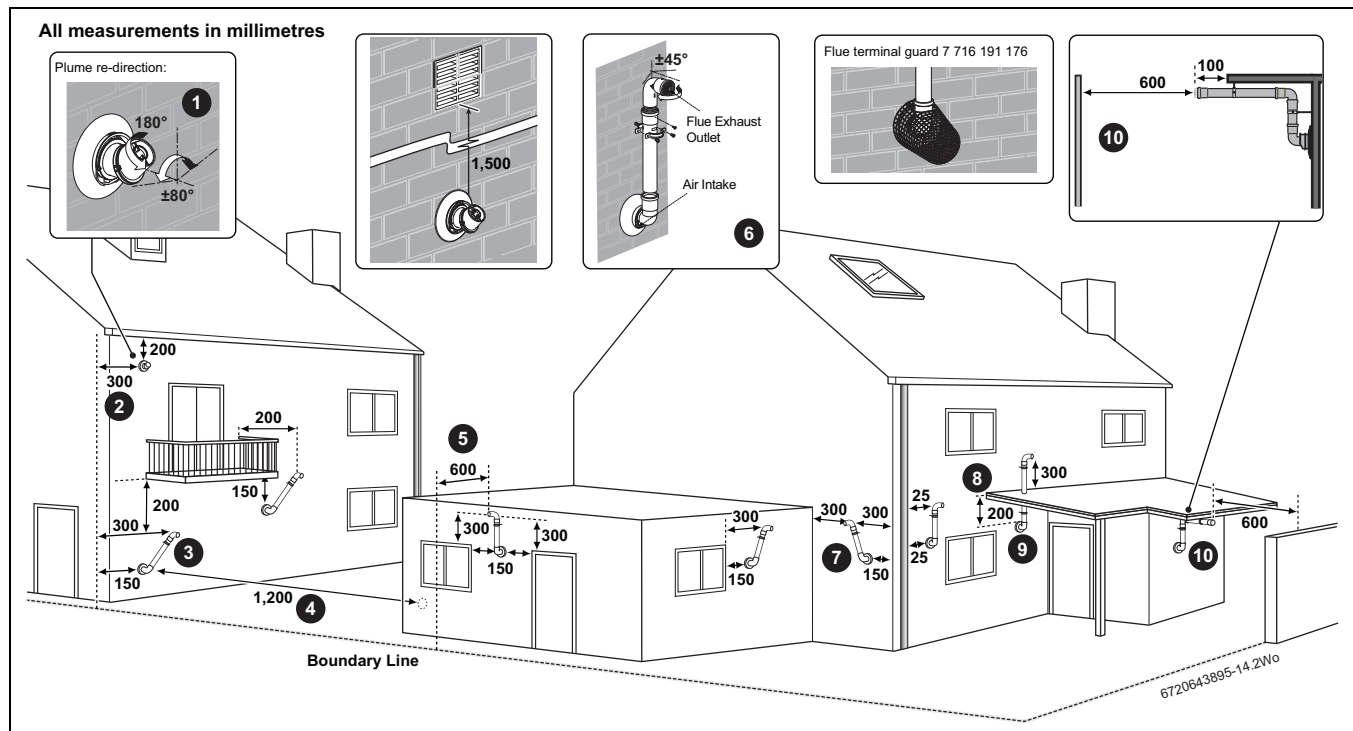

Fig. 24 Plume terminal positions



Maximum and minimum plume management lengths:

- ▶ A minimum distance of 500mm must be maintained between the plume management outlet and the flue air intake.
- ▶ The maximum plume management length is 4.5 metres for the appliances detailed on the front of this manual.
- ▶ The 45° bend is equivalent to 0.75 metres of straight plume management and the 90° bend is equivalent to 1.5 metres.



NOTICE:

- ▶ All measurements are the minimum clearances required.
- ▶ Refer to previous page for all concentric flue terminal positions unless the flue position is specified on the figure above "Plume terminal positions".
- ▶ Terminals must be positioned so to avoid combustion products entering the building.
- ▶ Support the flue at approximately one metre intervals and at a change of direction, use suitable brackets and fittings.

Key to illustration

1. This feature allows some basic plume re-direction options on a standard telescopic horizontal flue terminal. 300mm minimum clearances to a opening e.g. window. However the minimum clearances to an opening in the direction that the plume management is facing, must be increased to 1,500mm. Where the flue is less than 150mm to a drainpipe and plume re-direction is used the deflector should not be directed towards the drainpipe.
2. 300mm adjacent to a boundary line.
3. Plume Management kit air intake can be reduced to 150mm providing the flue exhaust outlet is no less than 300mm adjacent to a boundary line.
4. 1,200mm between terminals facing each other.
5. 600mm distance to a boundary line, unless it will cause a nuisance. BS 5440:Part 1 recommends that care is taken when siting terminal in relation to boundary lines.
6. Using a Plume Management kit the air intake measurement can be reduced to 150mm providing the flue exhaust outlet has a 300mm clearance. The initial horizontal run from the terminal elbow must have a minimum 10° fall back, (stop tabs in the elbow prevent less than 10°) to the appliance for proper disposal of condensate. Any further horizontal runs can be 3°.

– For details on specific lengths see relevant appliance Technical & Specification information.

7. Internal/external corners. The air intake clearance can be reduced to 150mm providing the flue exhaust outlet has a 300mm clearance.
8. Clearances no less than 200mm from the lowest point of the balcony or overhang.
9. 1,200mm from an opening in a car port on the same wall e.g. door or window leading into the dwelling.
10. 600mm distance to a surface facing a terminal, unless it will cause a nuisance. BS 5440: Part 1 recommends that care is taken when siting terminals in relation to surfaces facing a terminal.



Note:

- ▶ Installations in car ports are not recommended.
- ▶ The flue cannot be lower than 1,000mm from the top of a light well due to the build up of combustion products.
- ▶ Dimensions from a flue terminal to a fanned air inlet to be determined by the ventilation equipment manufacturer.
- ▶ Supply of combustion air and for the evacuation of combustion products shall not be installed on opposite walls of a building.

5 Installation



NOTICE: Risk of damage to appliance or accessories.

- ▶ All the previous pre-installation sections must be read and requirements met before starting the appliance or flue installations.



CAUTION: Risk of injury through incorrect lifting and carrying!

- ▶ Only lift a manageable weight, or ask for help.
- ▶ Bend the knees and keep the back straight with feet apart, when lifting or putting down heavy objects.
- ▶ DO NOT lift and twist at the same time.
- ▶ Lift and carry object close to the body.



WARNING: Integrity of combustion seal.

- ▶ DO NOT remove appliance side panels, they form the seal of the combustion chamber.



Unpacking details are found on the flap of the carton. Once the appliance is unpacked the installation can be commenced.

5.1 Important handling instructions

- It is advised that two people are used to carry the carton from the van to the point of delivery.
- Once the carton has been delivered, the outer carton is removed first. Care should be taken when releasing the straps. If a sharp implement is used make sure the outer carton is not pierced and that the implement is used in such a way so that it may not cause personal injury.
- All sharp objects must be covered or the blade retracted after use and put away in a safe place. Care should be taken when lifting the appliance from the base and the proper technique for safe lifting of any heavy object should be strictly observed.

Additional requirements for roof space installation:

- The appliance should be first unpacked before ascending ladder to loft space.
- Two sets of steps should be used.
- Two people should share the lifting of the appliance up to the loft hatch, where the appliance is entered into the loft space tilted and slid on its back into the loft.
- Once the appliance is removed from its packaging check the contents against the packing list.



CAUTION: Risk of damage to system or appliance!

- ▶ Before installing the appliance, ensure that the system has been cleaned as explained in section 4.1, page 14

5.2 Wall mounting template & flue openings



WARNING: Damage to property!

Damage caused by drilling into pipes, electrical cables, damp proof course or other hazards.

- ▶ Before drilling ensure that there are no obstructions or other hazards.



NOTICE: Residue, metal shavings, and contaminants in the system pipework can damage the appliance.

- ▶ Flushing the system pipework thoroughly and completely to remove all residue.
- ▶ Follow the instructions with respect to cleaning primary systems (→ Chapter 4.1, page 14).

Safety:

All relevant safety precautions must be undertaken. Protective clothing, footwear, gloves and safety goggles must be worn as appropriate.

Fixing the wall mounting Frame:



Existing wall fixings positions (Greenstar Si, i Junior & i System appliances)

- ▶ The existing wall fixings can be used only if they are still deemed by a competent person able to support the new appliance.

Refer to figure 25.

- The appliance wall mounting template shows the relative positions of the flue and the top and bottom fixings of the wall mounting frame.
- ▶ Fix the wall mounting template to the wall [1] in the desired position.
- ▶ Drill the four holes [2] indicated on the wall template for the wall mounting frame through the template.



The wall mounting template has been sized to allow for minimum clearances of 5mm sides, 200mm base and 170mm above appliance case (which is 30mm above a 100mm diameter flue elbow).

Flue outlet position

Rear flue outlet

Figure 25 shows the appliance wall mounting template with the flue centre lines of both the 100mm and 125mm flue systems.

- ▶ Mark centre line of flue to be used [3]; the external diameter of the hole can also be marked if required.
- ▶ If a 100mm diameter flue is to be used, a 125mm diameter hole is required. However, if using the weather sealing collar by pushing it through from inside the property, then a 150mm diameter hole is required to accommodate this.
- ▶ The 100mm flue turret has an in-built 3° angle.
- ▶ If extensions are to be added then the complete flue must rise at an angle of 3° from the appliance.
- ▶ Drill hole using a core drill or similar.

Side outlet:

- ▶ Mark from the centre line of the wall mounting template to the wall which the flue will pass through [4].
- ▶ Allow for a rise of 52mm per metre length of flue, to give a 3° angle.
- ▶ Clear any debris from the site.

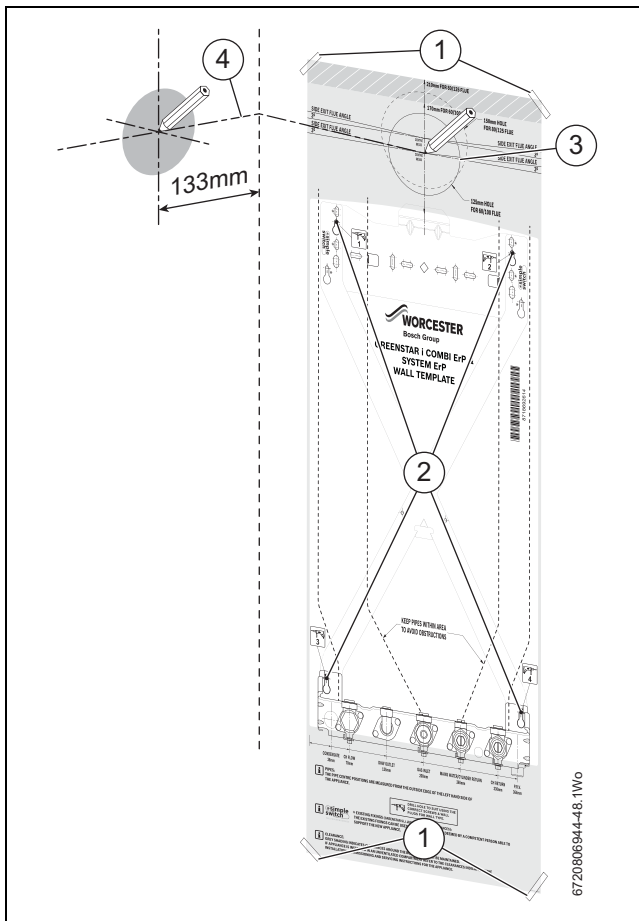

Fig. 25 Marking the flue position

Fixing the wall mounting frame

- ▶ Remove the wall mounting template.
- ▶ Secure the wall mounting frame to the wall, with appropriate fittings for appliance weight and wall type.

5.3 Appliance connections

CAUTION: When working on appliance connections.

- ▶ Isolate the mains gas supply before starting any work and observe all relevant safety precautions.
- ▶ Isolate/drain water pipework to be connected too and observe all relevant safety precautions.

Gas, water and condensate connections

- ▶ System pipes may be run vertically upwards behind the appliance or below it, (→ figure 20, section 4.8.1 on page 21).

Fitting the condensate pipework

Pre-fit the plastic condensate drain pipe through the wall frame as shown in figure 26.

- ▶ Secure the pipe to the wall at the last joint.
- ▶ Ensure the pipe protrudes through the wall frame by 25mm.
- ▶ If exiting through the wall, to run externally, the pipe must have a 3° fall and be increased to a 32mm insulated pipe.

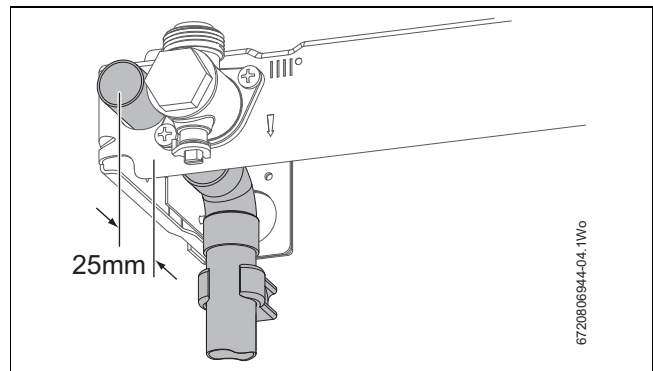

Fig. 26 Condensate drain pipe work detail

Preparing the wallframe

If using the optional filling loop or keyless version (not supplied with the appliance) fit it before hanging the appliance on the wall frame.

i The bonded washer supplied is for the Gas connection only.

- ▶ Fit sealing washers to service valves before hanging appliance.

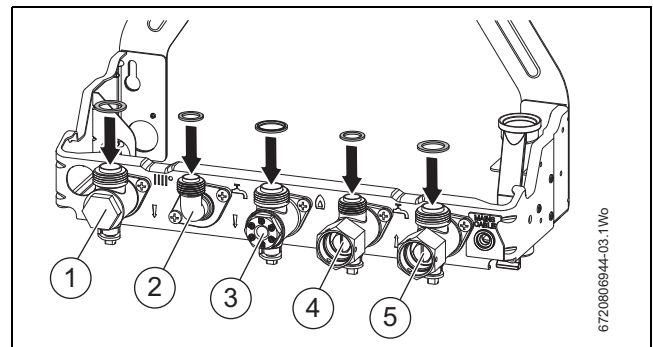

Fig. 27 Sealing washers

- [1] CH flow (22mm)
- [2] DHW outlet (15mm)
- [3] Gas inlet (22mm bonded washer)
- [4] Domestic Cold Water inlet (15mm)
- [5] CH return (22mm)

NOTICE: Before hanging the appliance onto the wall mounting frame ensure that the pressure relief valve connection is in the DOWN position refer to figure 28.

- ▶ This is located on the right hand side of the wall frame at the rear.
- ▶ Apply a smear of silicone lubricant to the seal to ease connection later.

- ▶ Pull the extended lever [1] forward and down until there is no further travel.

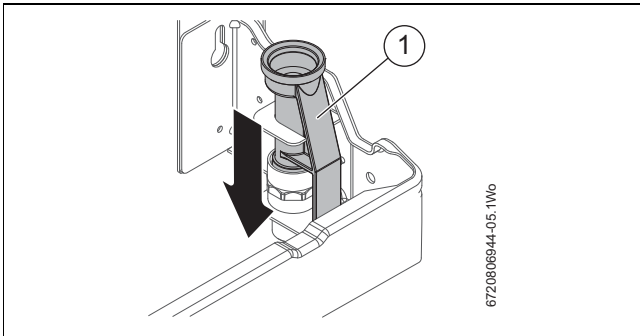

Fig. 28 PRV connection in the down position

5.3.1 Front panel removal

- ▶ Removing outer case
 - Undo and remove the two outer screws [1] securing the appliance casing to release the bottom of the front panel.
 - Lift front panel [2] off the two locating lugs [3] on the top of the appliance.

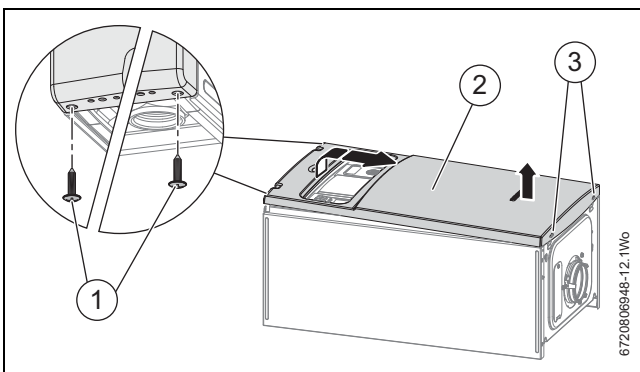

Fig. 29 Remove front panel

5.3.2 Hanging the appliance

CAUTION: Hanging the appliance

- ▶ Remove the plastic strip fitted to pipes before hanging the appliance.

i If required, the expansion vessel can be removed to reduce the lift weight during hanging the appliance. For details of expansion vessel removal (→ section 7.7.18, page 58).

- ▶ Hang the appliance on to the wall mounting frame by the centre hook.

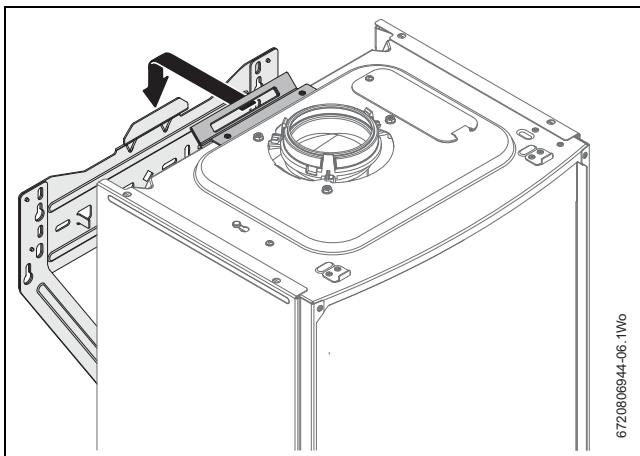

Fig. 30 Hanging the appliance

5.3.3 Pressure relief connections

! **NOTICE:** The pressure relief connector must be repositioned after the appliance has been correctly mounted to the wall mounting frame refer to figure 31.

i To ease assembly of components, apply silicone lubricant to sealing surfaces.

- ▶ Push the lever on the pressure relief connector UP until the stop on the inside of the handle is over the shoulder of the metal bracket to secure in place.

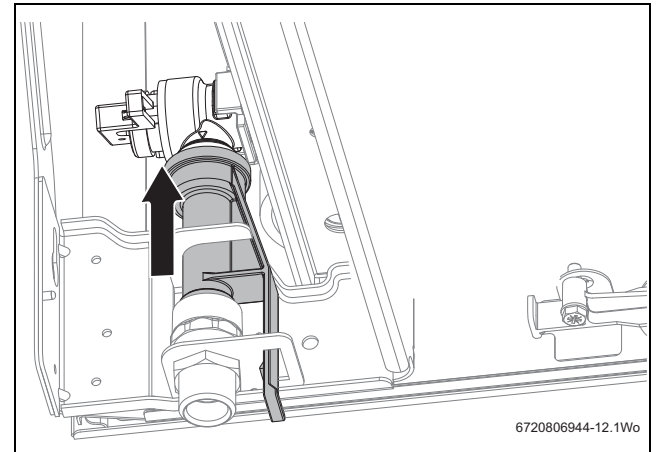

Fig. 31 PRV in the up position

5.3.4 Siphon removal

Access to the siphon

- ▶ Loosen the captive screw securing the control panel [1].
- ▶ Hinge open the control panel [2] into service position.

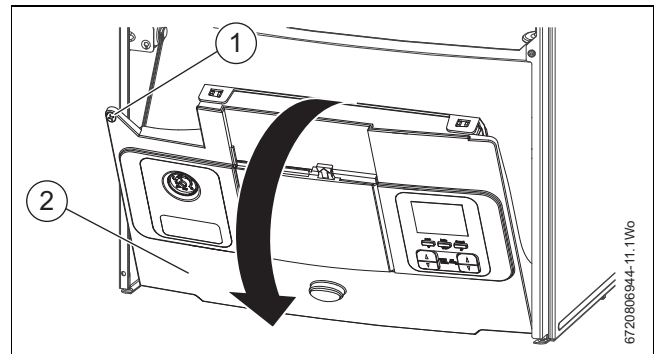

Fig. 32 Access for removing siphon

Siphon removal

Refer to figure 33

- ▶ Remove the siphon securing screw [1] completely.
- ▶ Rotate the siphon [3] level and to the right (until the upper arm [2] is parallel to the side casing), to release from the bayonet connection.
- ▶ Pull the siphon [3] straight down to clear the bayonet connection.
- ▶ Tilt the siphon [3] to the front and remove over the control box assembly [4].
 - Lifting the control box assembly [4] up a little may ease the removal of the siphon.

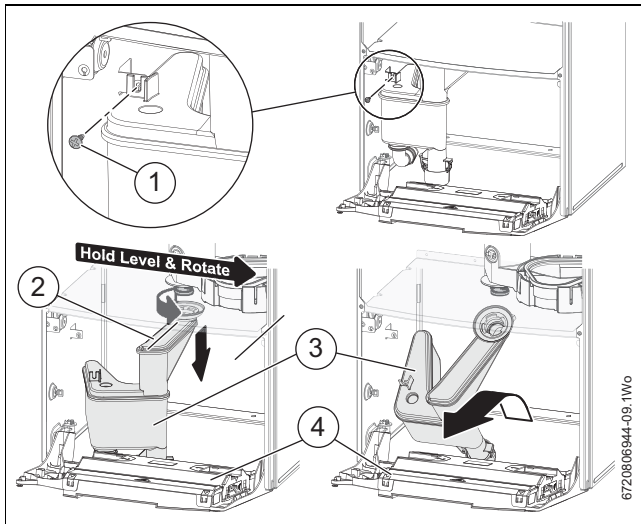

Fig. 33 Removing siphon

- ▶ Make connections to the heating system.
Connect the gas supply to the appliance gas cock 22mm compression.
Connect mains water in and DHW out.

5.3.5 Reconnecting the siphon

Refer to figure 34

- ▶ Slide the siphon [2] in over the control box assembly [3] with the sump tilted behind the control box.
 - Lifting the control box assembly [3] up a little may ease the fitting of the siphon.
- ▶ Push the siphon [2] up onto the sump connection, if it is not correctly aligned (the upper arm [1] is parallel to the side casing), the siphon will not engage.
- ▶ Rotate the siphon [2] level and to the left to secure the bayonet connection.
- ▶ Push the black discharge hose, onto the condensate outlet pipe.
- ▶ Screw the siphon in position to secure it [4].

i Ease the siphon fitting onto the sump connection by applying silicone grease to the bayonet.

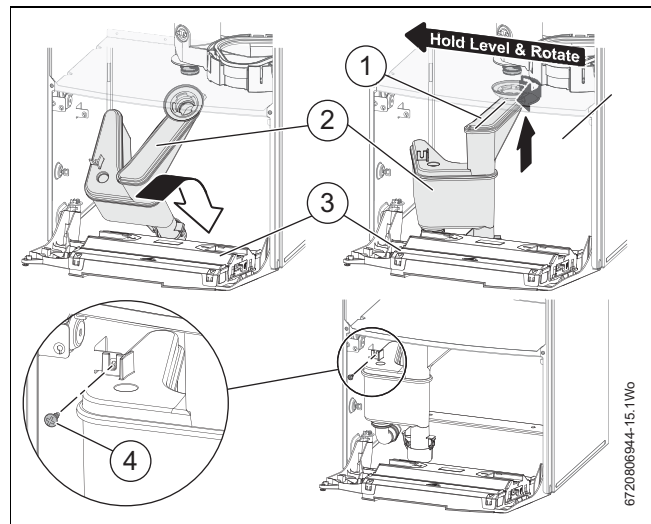

Fig. 34 Reconnecting the siphon

5.3.6 Filling the siphon

- ▶ Pour 200 to 250 millilitres of clean water through the inner flue opening to fill the siphon before running the appliance.

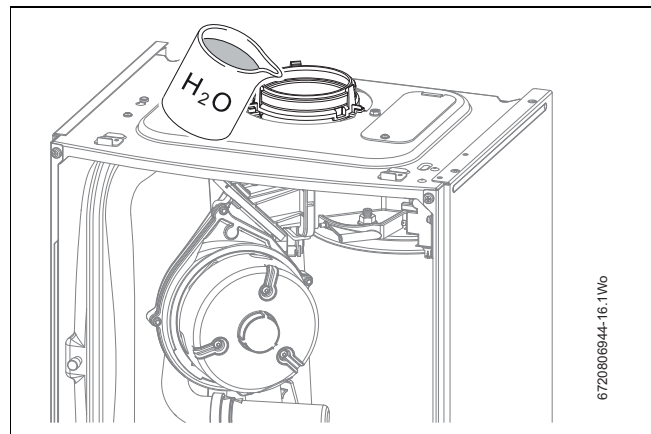

Fig. 35 Siphon fill

5.4 Flue turret/adaptor installation

i If replacing a Greenstar i Junior (2005-2015) or a Greenstar Si (2005-2013), the same rear exit flue hole will align and can be re-used if deemed in a suitable condition and in compliance with current legislation.

If replacing an existing side exit or a vertical flue, please check the flue accessories available for the Greenstar i before attempting to use the same hole.

The flue turret/adaptor for the appliance is secured using three retaining screws (figure 36, item [1]) which come in position on the appliance.

i To ease assembly of flue components, apply silicone lubricant to sealing surfaces.
Refer to the manual supplied with the flue kit for complete installation instructions.
For plume management effective lengths and the effective flue lengths, refer to details in section 4.9.

Refer to figures 36 & 37.

- ▶ Remove the three inner flue tube retaining screws [1]. The inner tube will be held in place in the appliance.
- ▶ Check the appliance flue seal [2] is correctly seated and apply silicone grease.

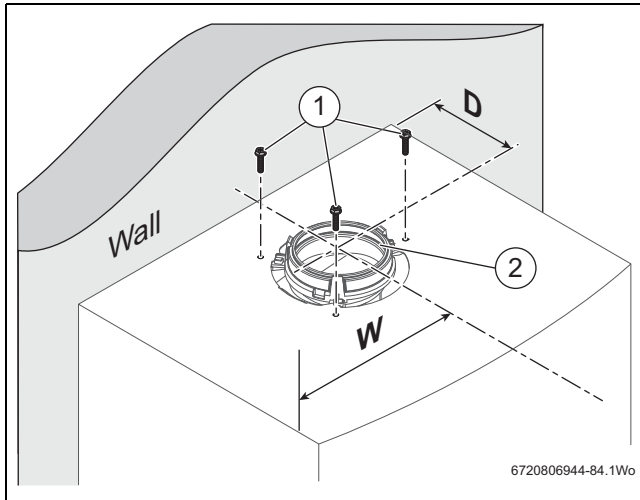

Fig. 36 Flue turret centre

[D] 133mm

[W] 200mm

- ▶ Align the flue turret/vertical adaptor to the appliance flue outlet with flat facing [3] to the rear of the appliance. The flue turret/adaptor should be pushed straight down, on to the appliance.
- ▶ The three inner flue tube retaining screws [1] are, re-used for the flue turret and replacement retaining screws [4] supplied with the adaptor kit are used to secure turret/adaptor to the appliance.

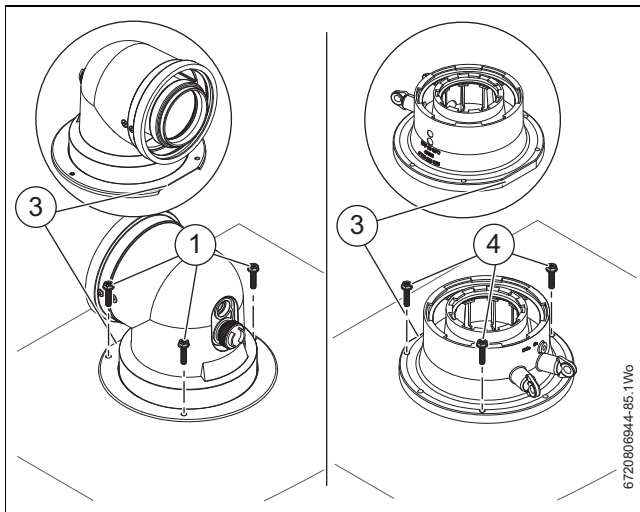

Fig. 37 Flue turret/adaptor connection

Additional notes and reminders:

- Ensure that all cut lengths are square and free from burrs.
- Ensure that the flue and seals are not damaged.
- The flue is sealed when assembled correctly, the components are pushed fully home and secured.
- The flue is set at an angle of 3° or 52mm per metre length.
- Support the flue at approximately one metre intervals and at a change of direction, use suitable brackets and fittings (flue bracket 100mm part number: 7 716 191 177, flue brackets 100mm x 6 part number: 7 716 191 178, flue bracket 125mm part number: 7 716 191 179)

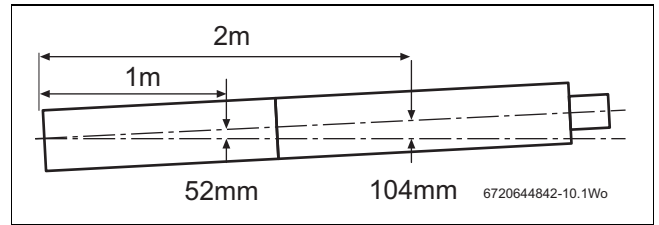

Fig. 38 Slope for condensate disposal

5.5 Electrical

! DANGER: Danger to life through electric shock!

- ▶ Before carrying out any work on electrical components, isolate them from the power supply (230 V AC) (fuse, circuit breaker) and secure against unintentional reconnection.

i The appliance is pre-wired with a mains supply cable. A spare strain relief block is supplied in case the pre-wired cable is not used.

- The mains electrical supply to the appliance must be through either a fused double pole isolator or a fused three pin plug and unswitched socket.
- The isolator shall be situated next to the appliance for new systems and, where practicable, replacement appliances.
- The isolator must have a contact separation of 3mm minimum in both poles. Any system connected to the appliance must not have a separate electrical supply.
- External fuse rating 3A.

Access to electrical connections:

- ▶ Remove appliance casing to access control panel (→ section 5.3.1).

Refer to figure 39.

- ▶ Loosen the captive screw [1] securing the control panel.
- ▶ Lower the control panel into the horizontal service position.
- ▶ Release the latches [2] using a thin bladed screwdriver. Arrows on the electrical cover indicate the position where the screw driver must be inserted to release the catches.

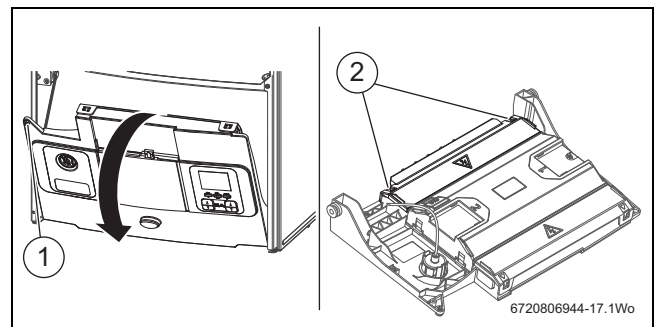

Fig. 39 Moving control panel into the service position

! NOTICE: Damage to control box!

Small pieces of wire can cause shorts and damage to electronics.

- ▶ When stripping wires always ensure copper strands do not fall into the control box.

Installation

Refer to figure 40

- ▶ Hinge open the connections cover [2] and use side retainers to lock in position.
- ▶ Wire any mains voltage equipment (timers, room thermostats etc. in the appropriately marked connector) within the mains voltage connections side [1].
- ▶ Wire any low voltage equipment (EMS BUS controller, outdoor sensor etc. in the appropriately marked connector) within the low voltage connections side [3].
 - The low voltage connectors are contained in a bag inside the connections cover (it is advised to fit the edge connectors even if they are not used).

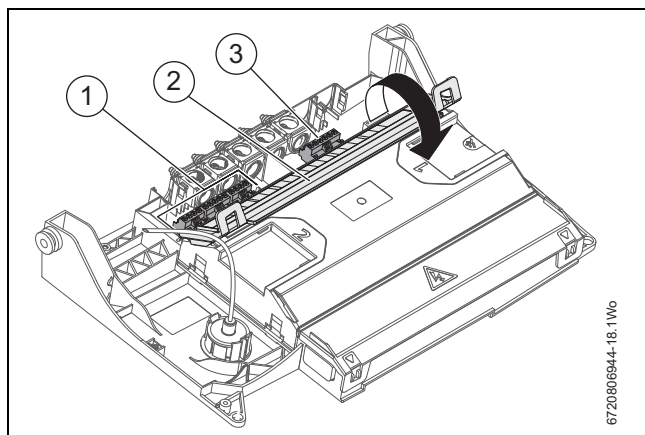

Fig. 40 Accessing the installer connections

- ▶ Pass the 230 V mains power cable, from the control box, through the grommet at the right hand side of the pre-plumbing manifold and route to the mains isolator next to the appliance.

Mains voltage connections

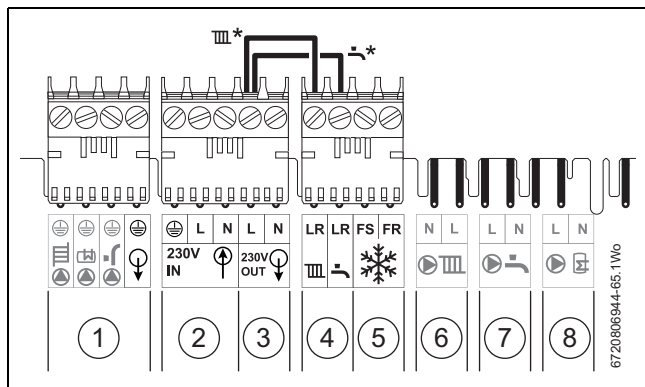

Fig. 41 Mains voltage connections

Legend to mains voltage terminal connections

1	Earth connections (green plug in connector pack found under installer connections cover, it is advised to fit the edge connector even if it is not used)
2	Appliance 230V mains supply
3	230V mains output to external controls/wiring centre
4	230V switched live inputs <ul style="list-style-type: none"> • CH - Remove link when connecting external CH control • DHW - Remove link when connecting external DHW control
5	External frost thermostat connections
6	CH circulation pump (NOT USED)
7	DHW charge pump (NOT USED)
8	DHW circulation pump (NOT USED)
*	Pre-wired links

Table 27



NOTE: DHW LR (Live Return) switched live.

- ▶ This input provides connection for a proprietary external twin channel control to time the DHW preheat function (link must be removed). All Worcester twin channel digital controls provide this functionality.

Low voltage connections

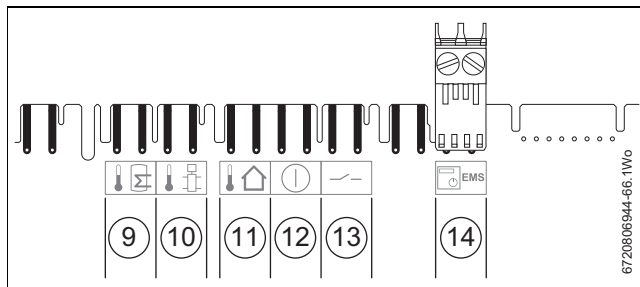

Fig. 42 Low voltage connections

Legend to low voltage terminal connections

9	Cylinder temperature sensor (NOT USED)
10	Low Loss Header sensor (NOT USED)
11	Outdoor weather compensation sensor (used when accessory outdoor sensor is connected)
12	External cut off switch (NOT USED)
13	Low voltage room thermostat (NOT USED)
14	External control system with EMS bus control, Worcester intelligent wall mounted controls. (orange plug in connector pack found under installer connections cover, it is advised to fit the edge connector even if it is not used)

Table 28

5.5.1 Mounting optional plug-in controls



Refer to the Programmer/Timer manual for set up and operation of the unit.

- ▶ When connecting Worcester plug-in or EMS intelligent controls, the links (→ items 3 & 4 in figure 41) must be left in the connection points.

Removing the blanking plate

- ▶ Remove appliance casing to access control panel.
- ▶ Grip the tab [1], pull up to disengage the clips.
- ▶ Pull forward to remove the blanking plate.

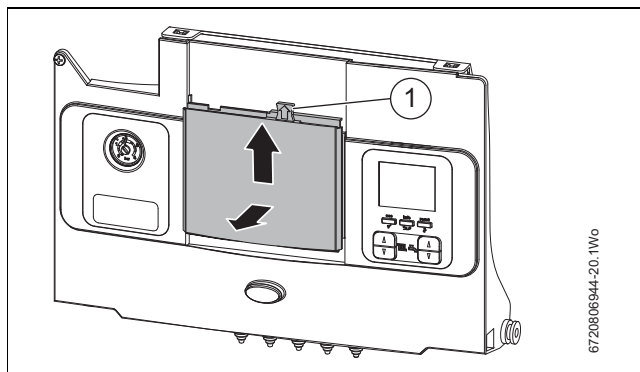

Fig. 43 Removing the blanking panel

Fitting the programmer/timer



When fitting EMS intelligent programmers, aligning the connector pins [2] and ensuring the ribbon cable fits into recess [4] can be ignored.

- ▶ Align the connector pins [2] with the socket on the circuit board [3] and push fully home. Ensure the ribbon cable fits into the recess [4].
- ▶ Align the Programmer/Timer and locating clips with the slots [5].

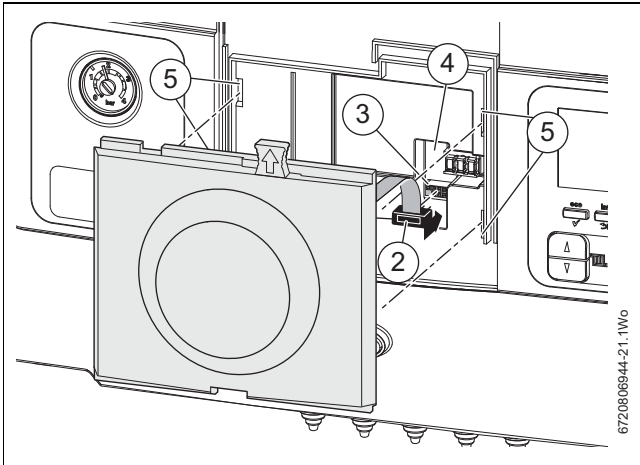

Fig. 44 Plug in connector

- ▶ Once the Programmer/Timer is aligned push the module into the slots.
- ▶ Push the module down to secure into position.

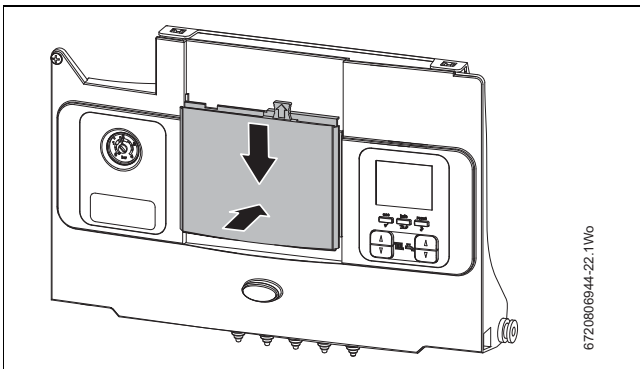

Fig. 45 Securing the module into the control panel

5.5.2 External controls - domestic installations

New complete system installations

If a new complete heating system is installed in a new build property or it is a first time installation in an existing property, the heating systems must conform to current building regulations Part L1a.

The exception to this are single storey, open plan dwellings where the living area is more than 70% of the total usable floor area. Then this type of dwelling can be controlled as one zone.

An alternative would be individual electronically controlled TRVs.

For dwellings with a floor area over 150m², separate time and temperature control for each zone is required. All radiators must have TRVs fitted in all rooms except bathrooms and rooms with thermostats.

Existing installations

For appliance replacements on an existing system, it is not necessary to zone the upstairs and downstairs separately, compliance with the zone requirements can be achieved by a single room thermostat or programmable room thermostat.

While the system is drained down, TRVs must be fitted to all rooms except the bathrooms and the room with the thermostat.

Appliance external controls connections

External controls connection:

- ▶ The electrical power supply to the external equipment is supplied from terminals L (Live), N (Neutral) [3] & earth [1].
- ▶ The Switch Live from the external equipment:
 - Heating/zone controls connects to terminal [4], remove pre-wired link.
 - Control for appliance Pre-heat function, optional. Hot water time controller connects to terminal [4], remove pre-wired link (only use when a Worcester controller has been fitted that does not have DHW pre-heat time control available, see table 12 or no Worcester controller fitted).
- ▶ External frost thermostat connections:
 - The Live supply is terminal FS [5]
 - The Switch Live is terminal FR [5]

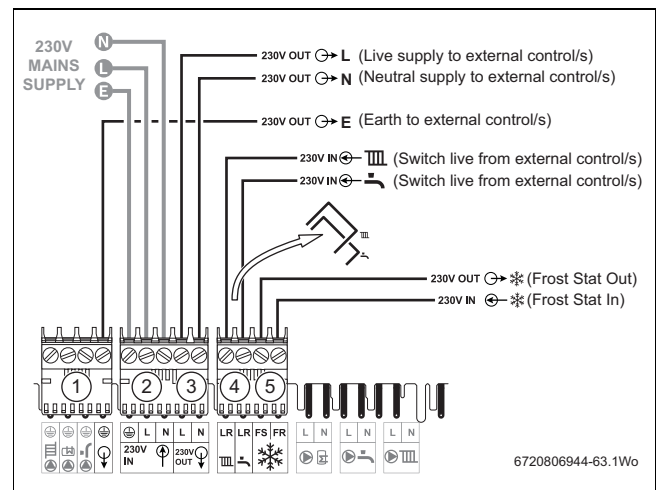

Fig. 46 External controls connections

- [1] Earth connections, external equipment
- [2] 230V mains supply to appliance connections
- [3] Live & Neutral feed to external controls connections
- [4] CH & DHW Switch Live from external controls connections
- [5] External frost protection connections

6 Commissioning

6.1 Pre-Commissioning checks



DANGER: Danger to life through electric shock!

- ▶ Before carrying out any work on electrical components, isolate them from the power supply (230 V AC) (fuse, circuit breaker) and secure against unintentional reconnection.

Check that the service and water pipes are connected to the correct position on the manifold.

Ensure that the washers have been fitted to the water connections and the bonded washer to the gas connection on the manifold, (→ figure 27, page 28).

1. - CH Flow (22mm)
 2. - DHW (15mm)
 3. - Gas inlet (22mm)
 4. - Domestic cold mains water in (15mm)
 5. - CH Return (22mm)
- ▶ Check the gas type specified on the identification plate, on the inside of the combustion chamber, matches that of the gas supply.
 - ▶ Turn on the main gas supply, check the gas pipe work, connections and rectify any leaks.
 - ▶ Check that the discharge hose has been connected to the siphon and condensate outlet pipe.
 - ▶ Check pressure relief drain pipe is correctly fitted and secure.



NOTICE: If the appliance is not to be commissioned immediately then, after successfully completing all of the checks and any rectification work:

- ▶ Close the gas valve
- ▶ Close the water shut off valve
- ▶ Isolate the gas supply
- ▶ Isolate the electricity supply
- ▶ Label appropriately

6.2 Filling the system

- ▶ Turn on the water main and open the system valves.
- ▶ Open all radiator valves.
- ▶ Fill the system via a WRAS approved filling loop or one of the optional Worcester Integral Filling Link accessories to between 1 and 1.5 bar then close the filling loop valve(s).
- ▶ The Automatic Air Vent will release any air trapped in the appliance.
- ▶ Manually vent all radiators, tighten when completed and check the system and correct any leaks.
- ▶ The appliance integral expansion vessel is pre-charged to 0.75 bar (equal to a static head of 7.5m (24.6ft)). A Schraeder type valve is fitted to the expansion vessel to allow for pressure adjustment if required.
- ▶ If an extra expansion vessel is fitted to the central heating return, adjust this to the same pressure as the appliance internal expansion vessel, refer to separate instructions with the extra expansion vessel.
- ▶ If required increase system pressure back to 1 bar.
- ▶ Isolate and remove filling loop connection to system or if using the optional integral filling connection (not supplied with the appliance) remove the key and place in its storage position on the bottom cover of the appliance.



An optional filling loop and keyless version are available to fill the system (not supplied with the appliance).

6.3 Water treatment



NOTICE:

- ▶ Artificially softened water must not be used to fill the central heating system.

Ensure that the system has been cleaned. Refer to section 4.1 of these instructions.

Flushing (Central Heating)

- ▶ Ensure the appliance is switched off.
- ▶ Open all drain cocks and drain the system while the appliance is hot.
- ▶ Close drain cocks and add a suitable flushing agent at the correct strength for the system condition in accordance with the manufacturer's instructions.
- ▶ Run the appliance/system at normal operating temperature for the time stated by the manufacturer of the flushing agent.
- ▶ Drain and thoroughly flush the system to remove the flushing agent and debris.

Inhibitor (Central Heating)

- ▶ Check drain cocks are closed and all radiator valves are open before adding a suitable inhibitor compatible with aluminium (or combined inhibitor/anti-freeze if the system is exposed to freezing conditions) to the heating system water in accordance with the manufacturers instructions.



The pH value of the system water must be less than 8 or the appliance warranty will be invalidated.

- ▶ Fill system via a WRAS approved filling loop to between 1 and 1.5 bar.
- ▶ Vent all radiators; tighten vents when complete.
- ▶ Re-pressurise if necessary to 1bar.
- ▶ Set all controls to maximum.
- ▶ Record the date when the inhibitor was added to the system in the Benchmark checklist.



NOTICE:

- ▶ The concentration of inhibitor in the system should be checked every 12 months or sooner if system content is lost.
- ▶ The addition of sealing agents to the system water is not recommended as this can cause problems with deposits left in the heat exchanger.
- ▶ In cases where all attempts to find a micro leak have failed, Worcester, Bosch Group supports the use of Fernox F4 leak sealer.

Water treatment products

Suitable water treatment products can be obtain from the following manufacturers:

ADEY	01242 546717 or www.adey.com
FERNOX	0870 601 5000 or www.fernox.com
SENTINEL	0800 389 4670 or www.sentinel-solutions.net

Table 29

6.4 Starting the appliance

CAUTION: Running the appliance

- ▶ Never run the appliance when the appliance/system is empty or partially filled.

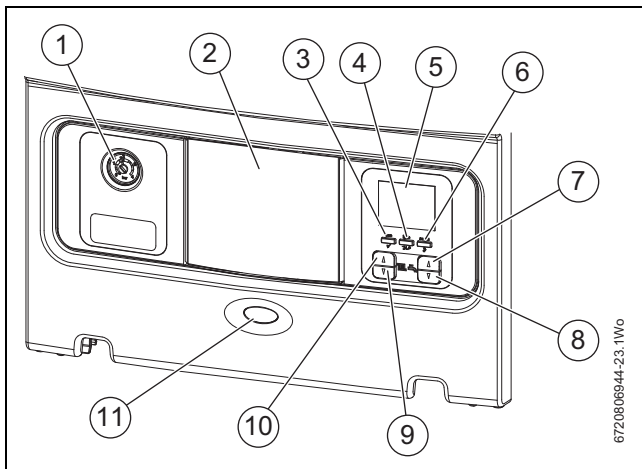

Fig. 47 Control panel

- [1] System pressure gauge
- [2] Position for optional programmer
- [3] ECO/OK button
- [4] Info/Return/Spanner button
- [5] Appliance display
- [6] Reset/Service engineer button
- [7] DHW settings increase button/menu scroll up button
- [8] DHW settings decrease button/menu scroll down button
- [9] CH settings decrease button
- [10] CH settings Increase button
- [11] Heat requirement demand and fault indicator light (blue)

Switching the appliance on/off:

- ▶ Turn on mains power, initially the “Appliance start up screens” will be displayed (refer to figure 48).
- ▶ Turn on any external controls
- ▶ Set the thermostatic radiator controls to maximum temperature
- ▶ Set the clock/programmer to continuously ON and the room thermostat to maximum temperature

The blue operation and fault indicator light will be illuminated when there is a demand for heat or hot water.

Press and hold the CH settings Increase button [10] to maximum.

The “burner on” flame symbol will be shown on the appliance display after a successful ignition sequence.

If all controls are working correctly the radiator symbol will appear on the display confirming a central heating demand has been received.

If no radiator symbol is shown then check all controls as no demand has been received.

If the appliance fails to light, the BLUE power indicator [11] will flash and an error code will appear on the display.

NOTICE: RESET

- ▶ Do not press the blue operation/fault diagnostic indicator [11] to reset the appliance.

To reset the appliance, press the reset button [6], the tick symbol will be displayed briefly for a successful reset.

6.4.1 Appliance start up screens

On initial start up, the following screens are displayed:

1. All the symbols are displayed for approximately two seconds.
2. The control will run an internal test for approximately 30 seconds.
3. When the internal test has been successfully performed, this screen is displayed:
 - The appliance is in stand-by.
 - The flow temperature sensor indicates the primary temperature from the heat exchanger (not the target set point).

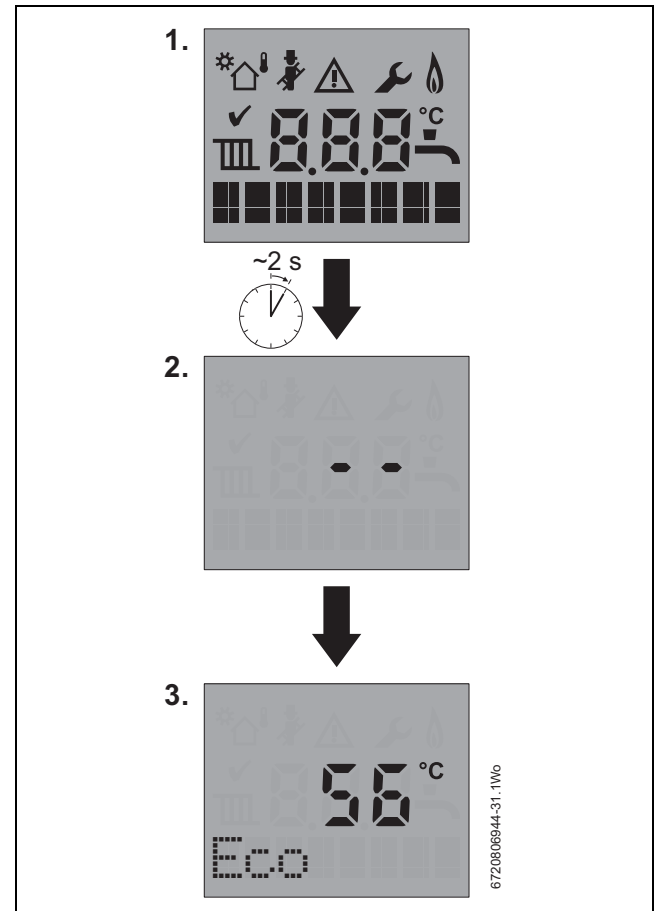

Fig. 48 Appliance start up screen

- ▶ If no adjustments are made for 30 seconds the back light is turned off.
- ▶ As soon as an adjustment is made, the screen will light up and the relevant information will be displayed.











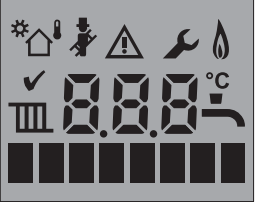



SCREEN DISPLAY	DESCRIPTION
All possible screen symbols 	This screen is displayed briefly during appliance start up and shows all the symbols that could be displayed.
Alpha/Numerical display 	Displays a temperature or appliance status code.
Text display 	Displays status, diagnostic code and short description information
Right hand arrows (text display) 	Use DHW-arrow buttons to alter the menu item.
Flashing T (text display) 	Appliance in component test mode
Flashing A (text display) 	Appliance in air purge mode
Hot water 	Displays this symbol during a DHW use.
Central Heating 	Displays this symbol during a CH use.
Chimney sweep mode 	Displays during service when the appliance is set to maximum or minimum output.
Alert 	Displays with the appliance status code and diagnostic code during a fault condition.
Service mode 	Displays when appliance is in service menu mode. For qualified engineers only.
Burner on 	The appliance is in operation and the flame is alight.
Centigrade 	Displays next to the temperature reading.
Confirmation 	This symbol confirms a setting change.

Table 30 Symbol description

Available menus

Text line display	Description
Various info (Info Menu)	Information from current status to appliance and component output readings, (→ section 6.4.2, page 36).
Benchmark Menu	Information for filling in Benchmark section, (→ section 6.5.11, page 42).
Boiler Setting	Appliance setup parameters, (→ section 6.5.13, page 43).
Master Settings	Appliance power output parameter, (→ section 6.5.14, page 44).
Test Menu	Component test function menu, (→ section 7.1.2, page 48).
Weather Sensor Settings	Outdoor weather sensor setup parameters, (→ section 6.5.12, page 42).
Various info (History Menu)	History of appliance errors and operational time, (→ section 7.1.1, page 48).
Reset to Factory Settings?	Factory reset function.



Table 31 Available menus

6.4.2 Info menu and operational status codes

These are not faults, but provide information concerning the current status of the appliance.

During normal appliance operation various Status codes can be displayed by entering the Info menu, for Status code list see table 33, page 37.

The first screen of the Information menu displays the current Status code, this will change as the appliance runs through the various modes and sequences.

- ▶ Press the  button to enter Info menu function.
- ▶ Using the DHW up/down arrow buttons to scroll through the menu.
- ▶ Press the  button to leave the info menu.

Info menu listing

Info menu No.	Description
i1	Current status <ul style="list-style-type: none"> Appliance current operating status (see table 33 for operational status codes).
i2	Previous status <ul style="list-style-type: none"> Appliance previous operational status (see table 33 for operational status codes).
i3	Maximum CH output <ul style="list-style-type: none"> Maximum CH output (kW) set on the appliance (set in menu 2.1A).
i4	Maximum DHW output <ul style="list-style-type: none"> Maximum DHW cylinder output (kW) set on the appliance (set in menu 2.1b).
i6	DHW flow detected <ul style="list-style-type: none"> A minimum flow rate of approximately 2.9 l/m has been detected by the appliance. <ul style="list-style-type: none"> YES = Flow detected No = No flow detected
i8	Ionization current <ul style="list-style-type: none"> Measured ionisation current (μA).
i9	Flow temperature <ul style="list-style-type: none"> Measured primary flow temperature of the appliance ($^{\circ}$C).
i11	DHW outlet temperature <ul style="list-style-type: none"> Measured DHW flow temperature of the appliance ($^{\circ}$C).
i12	DHW temperature setpoint <ul style="list-style-type: none"> Displays the current set temperature for the DHW.
i15	Outdoor sensor <ul style="list-style-type: none"> Temperature reading from outdoor temperature sensor, (only available if an outdoor sensor accessory is fitted)
i20	CU version <ul style="list-style-type: none"> Software version of the control box
i21	HMI version <ul style="list-style-type: none"> Software version of the HIS (Human Interface Software).
i22	HCM version <ul style="list-style-type: none"> Identification number of the HCM (Heating Control Module) and release version.

Table 32 Info menu
Operational status codes listing

Status code	Description
200	CH system is being heated.
201	DHW system is being heated.
202	Anti rapid cycle mode. <ul style="list-style-type: none"> The boiler has commenced anti-cycle period for CH. Can be adjusted in boiler settings (2.3b). Default 5 Minutes
203	System stand by
204	System waiting, primary flow temperature above set temperature point
208	Appliance in service Test mode (Min/Max)
265	EMS intelligent controller has forced stand-by-mode due to low heating load. <ul style="list-style-type: none"> The appliance is compensating for the power required from the EMS room controller and is less than the minimum output of the boiler.
268	Component test mode. <ul style="list-style-type: none"> Appliance is running the manual component test as activated in the menus.
270	Power up mode. <ul style="list-style-type: none"> Appliance is initialising.
283	Burner starting. <ul style="list-style-type: none"> The boiler prepares for a burner start. The fan and the pump are being controlled.
284	Gas valve(s) opened, flame must be detected within safety time. <ul style="list-style-type: none"> The boiler prepares for a burner start. The gas valve is being controlled.
305	Anti fast cycle mode, Domestic Hot Water keep warm function. <ul style="list-style-type: none"> Diverter valve is held in hot water position for a period of time (determined by the software) after hot water demand
357	Appliance in air purge mode. <ul style="list-style-type: none"> Primary Heat Exchanger air venting program active - approximately 100 seconds.
358	Three way valve kick. <ul style="list-style-type: none"> If the 3-way valve hasn't moved in up to 48 hours, the valve will operate once to prevent seizure.

Table 33 Operational status codes

6.5 Commissioning



NOTICE: Factory preset combustion settings:

- ▶ The combustion settings on this gas-fired boiler have been checked, adjusted and preset at the factory for operation on the gas type defined on the data plate.



NOTICE: Commissioning requirement and information:

- ▶ Combustion values must be checked and recorded in the Benchmark checklist, at the rear of this manual, after commissioning.
- ▶ DO NOT ADJUST THE AIR/GAS RATIO VALVE.
- ▶ The gas valve is factory set and must not be adjusted during commissioning if found to be out of tolerance, please contact Worcester, Bosch Group.



When running in the service mode, the appliance will operate both the central heating and the domestic hot water circuits. This is to allow sufficient time for this part of the commissioning procedure. It will be necessary to run water through the domestic hot water circuit to ensure that the appliance will not cycle on low heating demands.

Before proceeding, ensure you have checked:

- ▶ That the appliance has been installed in accordance with the installation instructions.
- ▶ The integrity of the flue system and flue seals, as described in section 7.2 of this manual.
- ▶ The integrity of the appliance combustion circuit and relevant seals.

6.5.1 Checking the gas inlet pressure

The inlet pressure to the appliance must be checked using the following procedure:

Measuring the inlet pressure

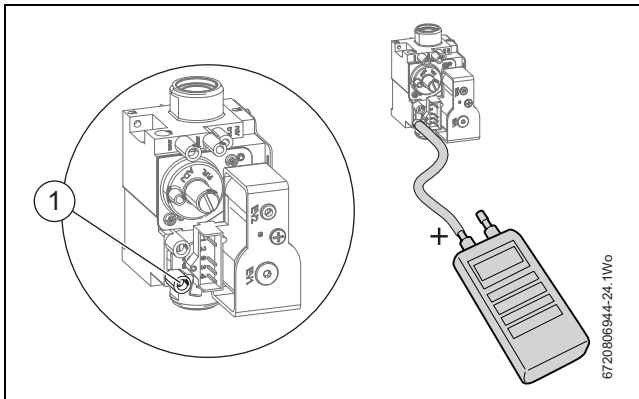



Fig. 49 Inlet pressure test point

- ▶ Close gas isolation valve.
- ▶ Slacken the screw in the inlet pressure test point [1] and connect a manometer.
- ▶ Open gas isolation valve.
- ▶ Measure the pressure with the appliance running at maximum.
 - Press the  button for at least 5 seconds.
 - The service button will be lit continually and the chimney sweep symbol  will be displayed at the top of the screen and the word "Max" will flash at the bottom of the screen.
- ▶ Check the gas supply working pressure at the gas valve inlet point is no less than the values shown in figures 50 or 51.

6.5.2 Gas pressure within the system



The appliance must be running at maximum output rate when performing the gas rate check.

Refer to the figures below for natural gas or L.P.G gas pressures.

The pressure at the appliance inlet must not be less than the pressure read at the meter minus:

- 1 mbar for Natural Gas
- 2.5 mbar for L.P.G.

The pressure drop from the meter to the gas valve must not be more than:

- 2.5 mbar for Natural Gas
- 4 mbar for L.P.G.

Natural gas				
	Allowed mbar pressure drop			
meter/regulator	across pipework	appliance inlet	across appliance	inlet, gas control valve
19 - 23	1	18-22	1.5	16.5 - 20.5
L.P.G.				
32 - 45	2.5	29.5 - 42.5	1.5	28 - 41
mbar range				

Table 34

If the pressure drops are greater than shown below, then this would indicate a problem with the pipe work or connections within the system.

≤	Equal to or less than
---	-----------------------

Table 35

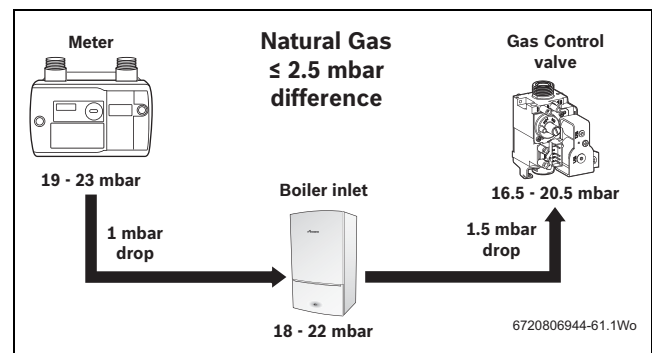

Fig. 50 Natural gas pressures

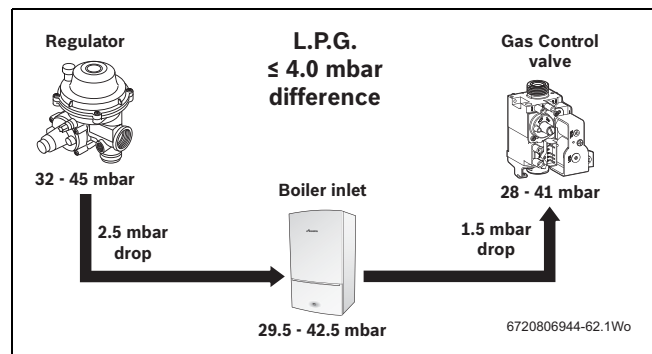

Fig. 51 L.P.G. pressures



NOTICE:

- ▶ Do not continue commissioning until the correct gas pressure is achieved.

6.5.3 Checking the gas rate



- ▶ The gas rate should be measured at the gas meter after the appliance has been operating for a minimum of 10 minutes at maximum output.
- ▶ See Technical data section on page 8 of this manual for gas rates and CO/CO₂ ratios.
- ▶ Where a gas meter is not available (e.g. L.P.G.) the CO/CO₂ must be checked.
- ▶ Gas rate must be checked with the appliance in service, maximum output mode.

6.5.4 Gas rate testing



Maximum output mode

- ▶ The diverter valve will go to mid position in chimney sweep mode. A hot water outlet can be opened to prevent the appliance from shutting down due to high temperature during testing.

- ▶ Ensure all other gas appliances are isolated.
- ▶ Set the appliance to maximum output by pressing the  button for at least 5 seconds.
The chimney sweep symbol  will be displayed at the top of the screen and the word "Max" will flash at the bottom of the screen. The appliance will ramp up to maximum output in 30 to 35 seconds.
- ▶ Ensure that the appliance has stabilised at maximum output.
- ▶ Carry out Gas rating procedures as described in current edition of the "Essential Gas Safety".
- ▶ If pressure and gas rate are satisfactory press the reset or return button and the appliance will return to normal operation.
 - If left in the service mode the control will return to normal operation after 15 minutes.

6.5.5 Checking for leaks during operation

- ▶ Use an approved leak detector to check all connections for possible leaks. The product must be certified as a gas leak testing agent.
- ▶ Do not allow the product to come into contact with the electrical wiring.

6.5.6 Domestic hot water

Controlling the hot water temperature:

The hot water temperature can be set to between approximately 40°C and 60°C using the DHW temperature control.

Domestic hot water pre-heat

Pre-heat reduces the time taken to produce hot water at the tap and is controlled by the ECO button ().

- ▶ Press the  button to select either state:
 - When Pre-Heat is displayed, the appliance will be in pre-heat mode (which will reduce the time taken to produce hot water at the tap).
 - When ECO is displayed the appliance will be in Economy mode and Pre-Heat will be off.

6.5.7 CO and combustion checks

The following combustion and flue integrity checks are mandatory from April 2014 and these values must be recorded on the Benchmark check list, at the back of this manual.

Once the gas rate and pressure have been confirmed as acceptable then the CO and combustion checks can be undertaken.

The flow chart is given for guidance, the details of the checks are given in the following sections:

- Checking flue integrity (→ section 6.5.8, page 41).
- Flue gas analysis (→ section 6.5.9, page 41).



The appliance case must be fitted whilst these checks are carried out.



NOTICE: BEFORE CO AND COMBUSTION CHECKS:

- ▶ Refer to section 6.5.1 and 6.5.3 to verify gas type, gas inlet pressure, and gas rate. Visually check the integrity of the whole flue system and confirm that all the components are correctly assembled, fixed and supported.
- ▶ The flue gas analyser must be the correct type as specified in BS 7967. Before use the analyser must have been calibrated as specified by the manufacturer. The installer must be competent in the use of the analyser. Check and zero the analyser in fresh air as specified by the manufacturer.
- ▶ The gas valve is factory set and must not be adjusted during commissioning if found to be out of tolerance, please contact the Worcester, Bosch Group help line 0330 123 3366.

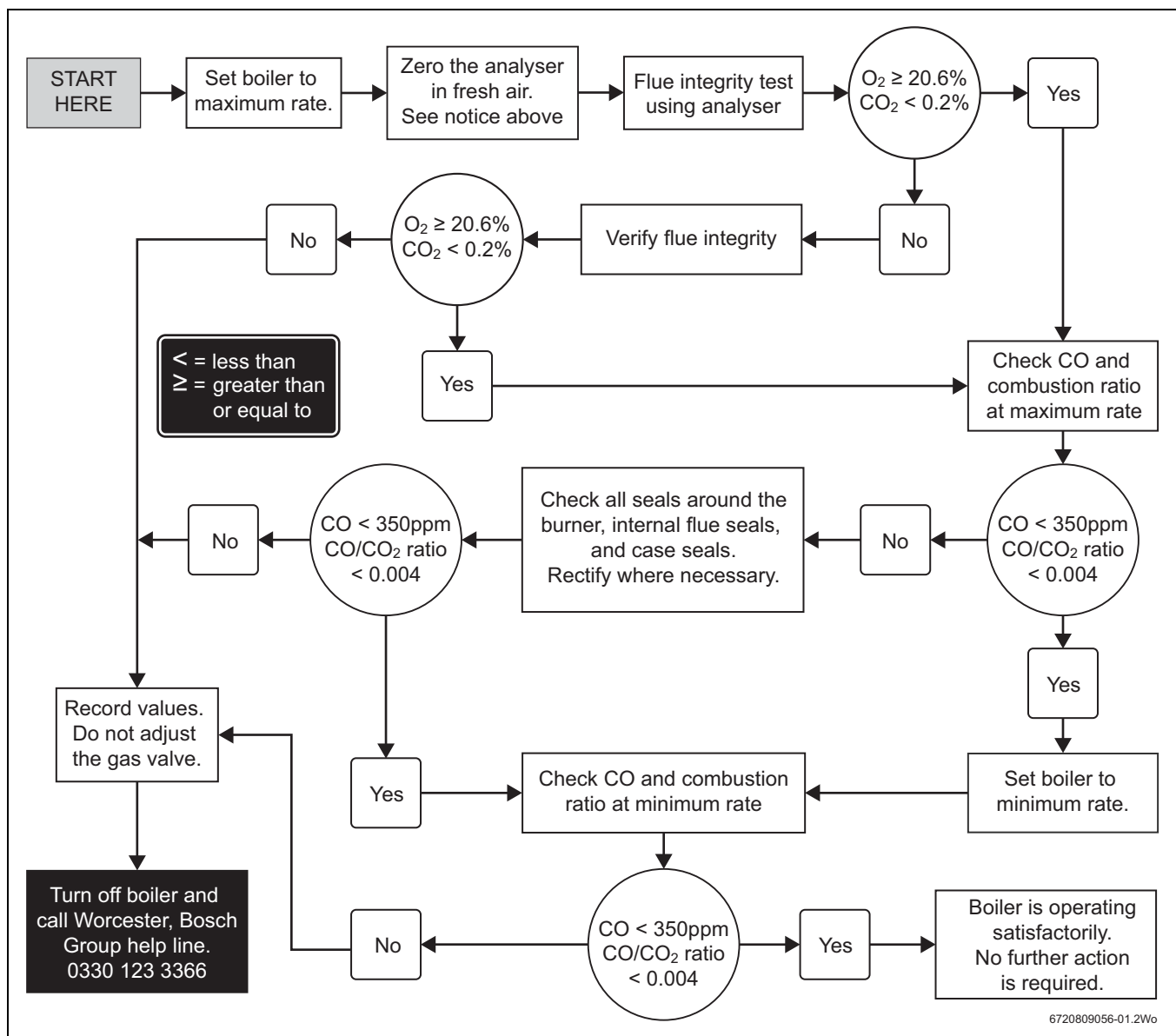

Fig. 52 Combustion check flow chart

6.5.8 Checking flue integrity



The appliance case must be fitted whilst this test is carried out.



Refit the test point plugs after the test has been completed.

The integrity of the flue system and performance of the appliance can be checked via the flue turret/adaptor sample points.

Refer to figure 53.

- ▶ With the appliance case on and the appliance running at maximum, remove the blanking plug for the air inlet sample point [2 or 3].
- ▶ Insert the analyser probe into the air intake test point [1].
- ▶ Allow the readings to stabilise and check that:
 - O₂ is equal to, or greater than 20.6%
 - CO₂ is less than 0.2%
- ▶ If the readings are outside these limits then this indicates that there is a problem with the flue system or combustion circuit.

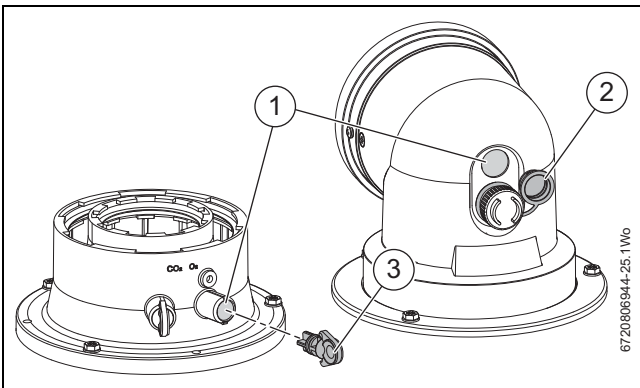

Fig. 53 Flue integrity test

- [1] Air inlet sample point
- [2] Flue turret air inlet blank plug (with retaining ring)
- [3] Flue adaptor air inlet blank plug

6.5.9 Flue gas analysis



NOTICE: Combustion testing

- ▶ Combustion testing must be carried out by a competent person. Testing must not be attempted unless the person carrying out the combustion check is equipped with a calibrated Combustion Analyser conforming to BS 7967 and is competent in its use.



Ensure that the gas inlet pressure has been checked and is satisfactory, refer to section 6.5.1

Combustion ratio test



When running in maximum output, and the water temperature is 65°C or less, the appliance will operate both the central heating and DHW circuits with the diverter valve in the mid position. It will be necessary to run sufficient water through the DHW circuit to ensure that the appliance will not cycle on low heating demands. This is to allow sufficient time for the setting procedure. When the water temperature reaches 75°C the diverter valve will switch to CH only.



Refit the test point plugs after the test has been completed.

Setting appliance to maximum



Maximum output mode

- ▶ The diverter valve will go to mid position in chimney sweep mode. A hot water outlet can be opened to prevent the appliance from shutting down due to high temperature during testing.

Refer to figure 54.

- ▶ Press the button for at least 5 seconds.
 - The chimney sweep symbol will be displayed at the top of the screen.
 - “Max” will flash at the bottom of the screen.
 - The appliance will ramp up to maximum output in approximately 30 to 35 seconds.
- ▶ Run the appliance at maximum output for at least 10 minutes.
- ▶ Remove the blanking plug for the flue gas sample point [2 or 3].
- ▶ Insert the analyser probe into the flue gas test point [1].
 - Ensure that the probe reaches the centre of the flue gas exhaust, adjust the cone on the probe so that it seals the sample point and correctly positions the end of the probe.
- ▶ Check that the CO is <250ppm and the CO/CO₂ ratio is <0.0025.

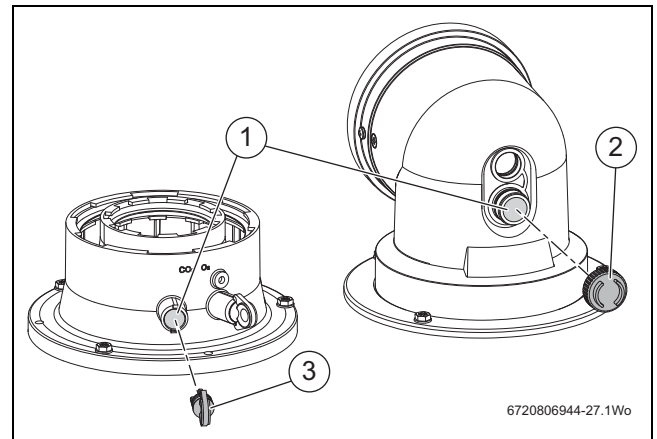

Fig. 54 Combustion test

- [1] Flue gas sample point
- [2] Flue turret flue gas blank plug
- [3] Flue adaptor flue gas blank plug

Setting the appliance to minimum

Whilst the appliance is in Chimney sweep mode (the chimney sweep symbol will be displayed at the top of the screen:

- ▶ Set the appliance to minimum power by pressing the DHW down arrow button.
 - “Min” appears at the bottom of the screen.
 - The appliance will take 30 to 35 seconds to ramp down to minimum output.
 - Allow the appliance to stabilise at minimum output.
- ▶ Check that the CO is <200ppm and the CO/CO₂ ratio is <0.002.
- ▶ If correct, press the button and the appliance will return to normal operation.

6.5.10 Service reminder function



Service reminder function active:
Setting the appliance to minimum or maximum mode when the service reminder function is active, a service reminder reset notification is displayed h13/H13.

- ▶ Reset the service reminder value in boiler settings menu (→ section 6.5.13, page 43).

This function allows a reminder to be set for the service of the appliance. It is recommended that the appliance is serviced annually (set the reminder for 12 months). The service reminder time functional flow diagram can be found in figure 55.

Boiler settings Menu list	Description
2.5F - Service reminder time	Set the value for service reminder. Default value is 0 ▶ Range from 0 - 72 (months) – 0 = Service reminder switched off – 1 - 72 = Number of months till reminder

Table 36 Service reminder time - 2.5F from boiler settings menu

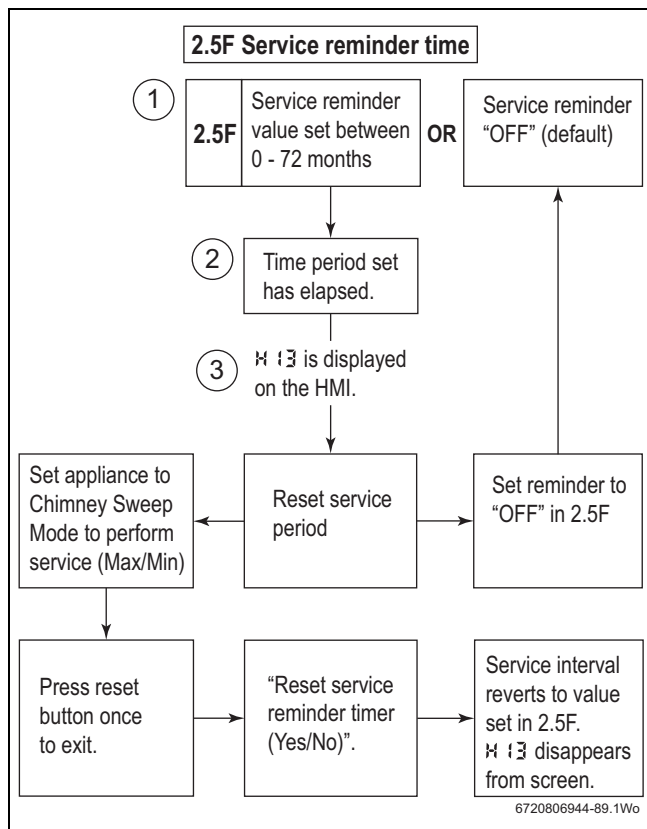

Fig. 55 Service reminder function - 2.5F

- [1] HMI menu 2.5F will display the selected service internal period in months. This menu item does not decrease as months elapse.
- [2] The appliance has a built in time counter which starts counting once a service interval is set. Setting a new interval value will reset this counter.
- [3] H13 displayed on the HMI indicates that a service is now due.

6.5.11 Benchmark menu

The Benchmark menu function provides additional information to complete the Benchmark Checklist, table 37 for details.

- ▶ Press the and buttons for approximately 5 seconds to enter appliance menu function.
- ▶ Using the DHW up/down arrow buttons to scroll through to the Benchmark menu.
- ▶ Press the button to select the menu.
- ▶ Using the DHW up/down arrow buttons to scroll through the menu.
- ▶ Press the button to select the menu item.
- ▶ Press the button to leave the info menu.

Benchmark Menu list	Description
1.1A - CH flow temperature	Flow temperature (monitored from primary sensor)
1.1C - DHW outlet temperature	DHW temperature (monitored from DHW sensor)
1.1d - DHW flow rate	Displays CMI flow rate through turbine (l/min)

Table 37 Benchmark menu

6.5.12 Weather sensor settings menu

If not activated the display will show “No menu”.

The appliance will auto-detect the connection of a Worcester outdoor sensor which will enable basic weather compensation with the settings controlled from the appliance.

The weather sensor settings menu provides configuration settings when outdoor sensor accessory is fitted (the menu only becomes available if an outdoor sensor accessory is fitted), see table 38 for details.

Weather compensation explained

Weather compensation will alter the flow temperature of the boiler depending on the outside air temperature. There are two types:







- Basic weather compensation control. ErP Class II control.
 - Worcester outdoor sensor accessory with Greenstar i boiler provides this.
- Advanced weather compensation control. ErP Class VI control.
 - A Worcester Intelligent weather compensation controller with outdoor sensor provides this.
 - If a Worcester Intelligent weather compensation controller with outdoor sensor is installed, the following procedure **must** be observed to enable the advanced weather compensation function.

Enable advance weather compensation control when Worcester Intelligent weather compensation controller and outdoor sensor is installed.

- ▶ Enter the appliance menu function.
 - Press the and buttons for approximately 5 seconds to enter appliance menu function.
- ▶ Using the DHW up/down arrow buttons to scroll through to the Weather Sensor settings menu.
- ▶ Select menu item 5.W1 - WDM mode enable using the button.
- ▶ Toggle this setting to OFF and select with button.
- ▶ Press the button twice to exit to the default appliance screen.

The Greenstar i built-in basic weather compensation needs to be disabled as the intelligent weather compensation controller adjust the compensation curve in parallel with the room thermostat to improve room comfort.

Weather sensor settings (basic weather compensation control)







- ▶ Press the  and  buttons for approximately 5 seconds to enter appliance menu function.
- ▶ Using the DHW up/down arrow buttons to scroll through to the Weather Sensor settings menu.
- ▶ Press the  button to select the menu.
- ▶ Using the DHW up/down arrow buttons to scroll through the menu.
- ▶ Press the  button to select the menu item.
- ▶ Using the DHW up/down arrow buttons to scroll through the adjustment options.
- ▶ Press the  button to confirm the adjustment.
- ▶ Press the  button to leave the info menu.

Weather Sensor settings menu list	Description
5.W1 - WDM mode enable	<ul style="list-style-type: none"> ▶ Enable the interaction with the connected WDM (weather dependent module). - OFF = Disabled - On = Enabled
5.W2 - WDM Max. temperature	Set maximum supply temperature when outdoor sensor temperature is equal to or greater than -10 °C. ▶ Range from 20 - 90 (°C)
5.W3 - WDM Min. temperature	Set minimum supply temperature when outdoor sensor temperature is equal to or less than 20 °C. ▶ Range from 2 - 90 (°C)
5.W5 - Frost prot. enable	<ul style="list-style-type: none"> ▶ Enable system frost protection function. - OFF = Disabled - On = Enabled

Table 38 Weather sensor settings menu

6.5.13 Boiler settings menu

The Boiler settings menu provides additional functionality of the appliance, table 39 for details.







- ▶ Press the  and  buttons for approximately 5 seconds to enter appliance menu function.
- ▶ Using the DHW up/down arrow buttons to scroll through to the Boiler settings menu.
- ▶ Press the  button to select info menu.
- ▶ Using the DHW up/down arrow buttons to scroll through the menu.
- ▶ Press the  button to select the menu item.
- ▶ Using the DHW up/down arrow buttons to scroll through the adjustment options.
- ▶ Press the  button to confirm the adjustment.
- ▶ Press the  button to leave the info menu.

Boiler settings Menu list	Description
2.1A - Max CH power	Maximum heating output (kW).
2.1b - Max. DHW power	Maximum domestic hot water output (kW).
2.1C - Pump head select	<ul style="list-style-type: none"> ▶ Selectable values for pump head. - 0 = Variable speed - 1 = Constant pressure low - 2 = Constant pressure low/middle - 3 = Constant pressure middle/high - 4 = Constant pressure high
2.1E - Pump switch mode setting	<ul style="list-style-type: none"> ▶ Selectable values for pump head. - 4 = Pump energy save on - 5 = Depends on heat request
2.2C - Air purge mode	<ul style="list-style-type: none"> ▶ Selectable values air purge mode. - OFF = Air purge mode off - AUt = Air purge mode automatic - On = Air purge mode on
2.3b - Anti fast cycle time	Anti cycle function (starts from burner ignition). ▶ Range from 3 -45 (mins)
2.3C - Anti fast cycle flow temperature	Anti cycle temperature hysteresis (temperature differential). ▶ Range from -30 - 0 (k)
2.5F - Service reminder time	Set the value for service reminder. Refer to section 6.5.10, page 42. Default value is 0 ▶ Range from 0 - 72 (months) <ul style="list-style-type: none"> - 0 = Service reminder switched off - 1 - 72 = Number of months till reminder
2.7A - System LED select	<ul style="list-style-type: none"> ▶ Operational and fault indicator (blue). - OFF = LED only active for errors - ON = LED active for flame activity and errors (default)
2.9E - Turbine signal delay	Delay for DHW demand. ▶ Range from 2 - 12 (times 0.25 second)

Table 39 Boiler settings menu

6.5.14 Master settings menu

The Master settings menu allows for the adjustment boundaries to be set. These will set limits for the actual values that can be set in the Boiler settings menu.

- ▶ Press the  and  buttons for approximately 5 seconds to enter appliance menu function.
- ▶ Using the DHW up/down arrow buttons to scroll through to the Power settings menu.
- ▶ Press the  button for approximately **5 seconds** to select the menu.
- ▶ Press the  button to select the menu item.
- ▶ Using the DHW up/down arrow buttons to scroll through the adjustment options.
- ▶ Press the  button to confirm the adjustment.
- ▶ Press the  button to leave the info menu.

Master settings menu list	Description
3.1A - Max. CH output (kW)	Adjust the maximum CH output of the appliance (kW)
3.1b - Max. DHW output (kW)	Adjust the maximum DHW output of the appliance (kW)
3.2b - Max flow temperature setpoint	Adjust the maximum CH flow temperature setpoint
3.3d - Min appliance power (kW)	Adjust the minimum output of the appliance (kW)

Table 40 Master settings menu

The menu shows the appliance's minimum and maximum limits which can be adjusted in this menu.

The appliance will revert to the adjusted settings in the Master settings menu following a power interruption.

The Master settings menu cannot be factory reset.

6.6 Finishing commissioning

6.6.1 Replace front panel:

- ▶ Replace front panel making sure that the securing points are properly located.
- ▶ Lift front panel onto the two locating lugs on the top of the appliance [1].
- ▶ Push the bottom of the panel into position and tighten bottom two screws.

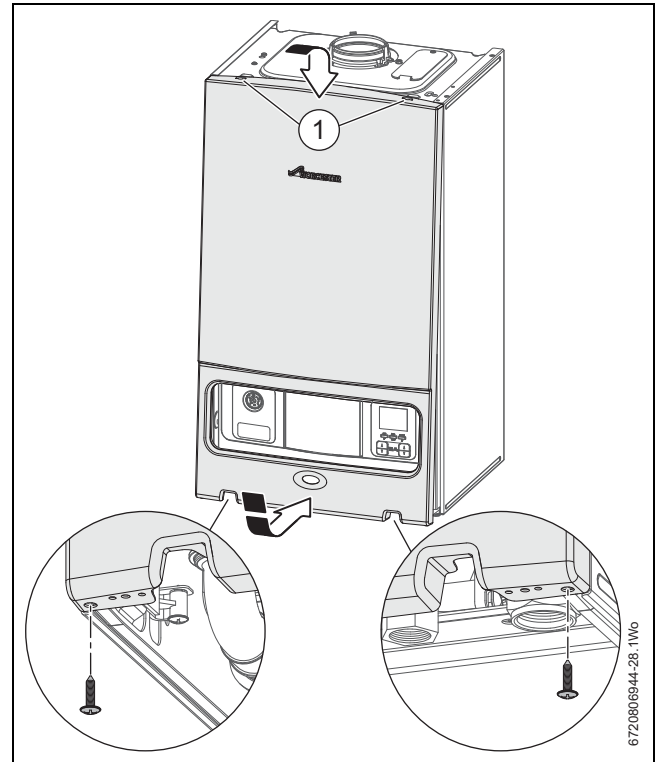

Fig. 56 Fitting case

6.6.2 Fitting fascia flap

- ▶ Rotate the hinge [1] to be in-line with the flap and present the flap assembly horizontally up to the fascia.
- ▶ Push the pegs on the hinge into the two slots in the front of the fascia and close the flap.

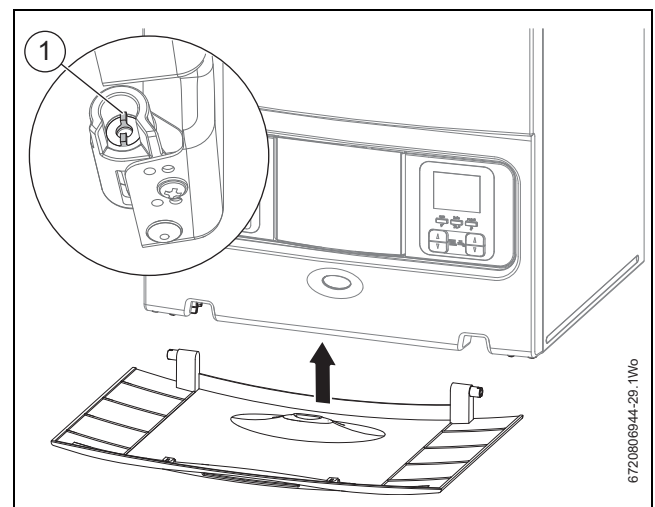

Fig. 57 Fitting the flap

6.6.3 Installing bottom panel

- ▶ The bottom panel slides onto two ledges [1] either side of the appliance frame.
- ▶ Hold the panel up against the underside of the appliance. Slide towards the rear, until there is no more movement.
- ▶ Slide the panel forward until the catch [2] is fully engaged.

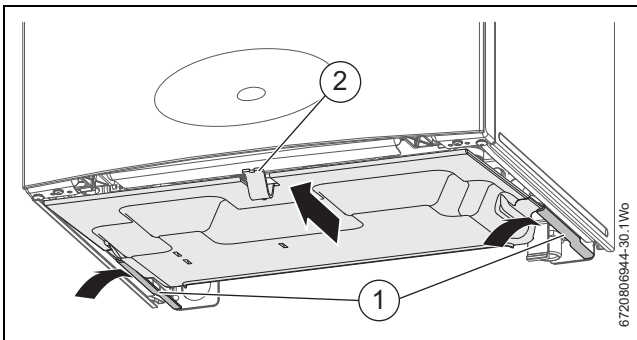

Fig. 58 Bottom panel installation

NOTICE: Every time the power to the appliance is turned off and on, the appliance enters a learning mode and may take some time to optimise the appliance performance. This time is variable and is dependant on hot water and central heating demand.

6.6.4 Setting the central heating temperature

General central heating temperature adjustment

The standard display will show the current appliance temperature [1].

- ▶ Press the central heating increase or decrease adjustment buttons [2] to desired flow temperature. The temperature adjustment is displayed [3] according to adjustment made (the adjusted value flashes while it is in edit mode).
By holding the desired increase/decrease button the temperature displayed begins to change by larger increments.
- ▶ Press the OK button to confirm value selection, the display will also return to main screen.

-or-

- ▶ Wait 4 seconds for auto confirm and the display will return main screen.

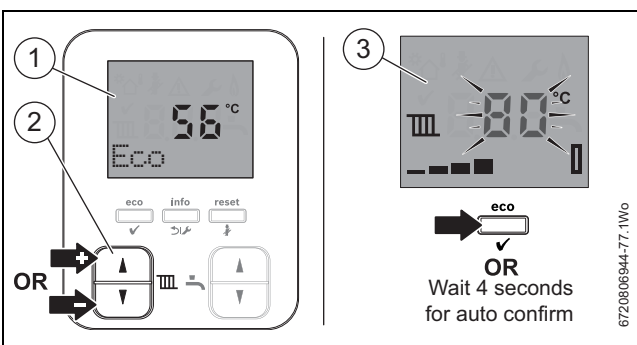

Fig. 59 Setting central heating temperature

Economic central heating temperature

The economic value sets the maximum flow temperature to the most efficient operation of the appliance.

The standard display will show the current appliance temperature [1].

- ▶ Press both the central heating adjustment buttons [2].
The display will change to the economic value for the central heating, (this is depending on the minimum and maximum temperature setpoint values)

- ▶ Press the OK button to confirm value selection, the display will also return to main screen.

-or-

- ▶ Wait 4 seconds for auto confirm and the display will return main screen.

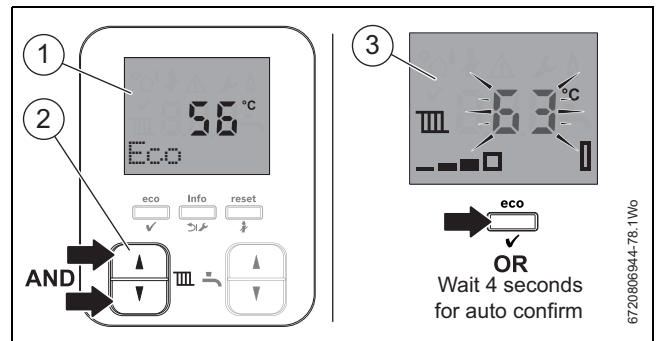

Fig. 60 Setting economic central heating temperature

6.6.5 Setting the domestic hot water temperature

General domestic hot water temperature adjustment

The standard display will show the current appliance temperature [1].

- ▶ Press the domestic hot water increase or decrease adjustment buttons [2] to desired flow temperature. The temperature adjustment is displayed [3] according to adjustment made (the adjusted value flashes while it is in edit mode).
By holding the desired increase/decrease button the temperature displayed begins to change by larger increments.
- ▶ Press the OK button to confirm value selection, the display will also return to main screen.

-or-

- ▶ Wait 4 seconds for auto confirm the display will return main screen.

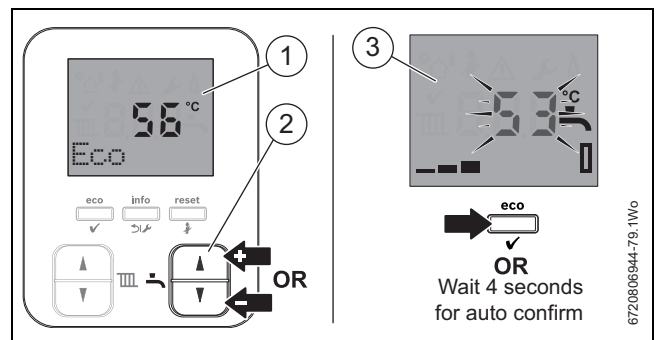

Fig. 61 Setting domestic hot water temperature

Mid point domestic hot water temperature

The mid point sets the maximum temperature for the hot water to 50 °C.

The standard display will show the current appliance temperature [1].

- ▶ Press both the hot water adjustment buttons [2].
The display will change to the mid point for the hot water, (this is depending on the minimum and maximum temperature setpoint values)
- ▶ Press the OK button to confirm value selection, the display will also return to main screen.

-or-

- ▶ Wait 4 seconds for auto confirm and the display will return main screen.

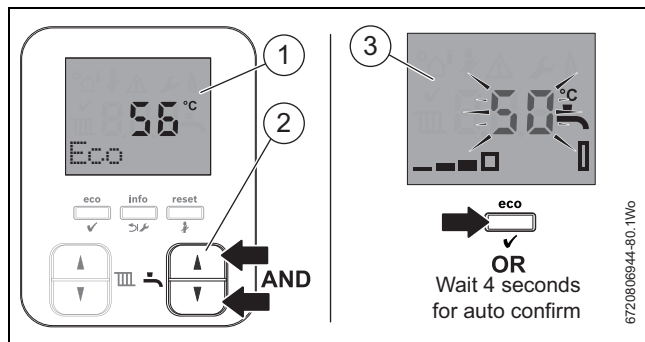

Fig. 62 Setting economic domestic hot water temperature

6.6.6 Eco/Preheat mode activation

- Eco mode is an energy saving feature which disables the Preheat function. Eco is enabled by default, during the initial appliance start up and Eco is displayed.
- Preheat mode, the hot water heat exchanger is kept pre-heated to reduce the time taken to deliver hot water at the tap.

In the Preheat mode, if there has been no demand for hot water for 24 hours the appliance will save energy by suspending Preheat until there is a demand for hot water. At this time Preheat mode is re-activated.

- ▶ Press the eco button (approximately 1 second) to manually switch between eco [1] and preheat [2] modes.
Depending on which mode the appliance is in, pressing the eco button (approximately 1 second) switches from one mode to the other.

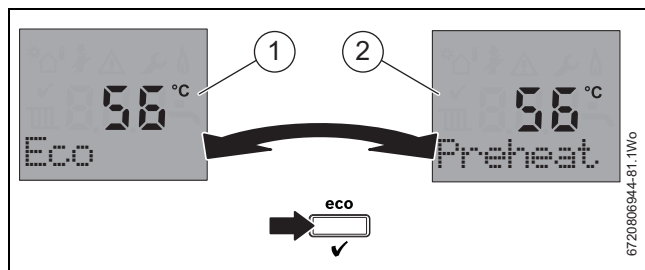

Fig. 63 Eco/Preheat manual switching

When a twin channel programmer is fitted/connected, the Eco/Preheat option can be selected via the programmer (for Worcester plug-in controls see table 12, page 20).

- Programmer hot water channel OFF periods:
 - Eco mode active and indicated on the appliance display.
 - Clock symbol is also indicated on the appliance display.
- Programmer hot water channel ON periods:
 - Preheat mode is active and indicated on the appliance display.

6.6.7 Toggle basic adjust mode

Basic adjust mode locks key functions preventing accidental adjustment of the heating flow temperature, Eco mode and service functionality. When in basic adjust mode, a message appears on the display when a disabled button is pressed.

Only the following functions are available whilst in basic adjust mode:

- Domestic hot water temperature adjustment
- Info menu button
- Reset button

To enable /disable the basic adjust mode operation of the appliance (domestic hot water adjustment only when basic mode active):

- ▶ Press and hold for 5 seconds the central heating increase [1] and domestic hot water decrease [2] adjustment buttons to toggle activation.

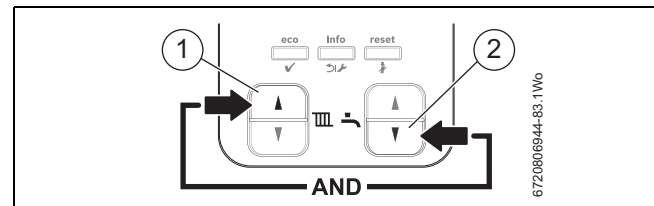

Fig. 64 Basic adjust mode activation toggle

6.6.8 Hand over

- ▶ Complete the Benchmark Gas Boiler Commissioning Checklist at the back of this manual.
- ▶ Open the fascia flap by hinging the flap downwards using the curved hand hold in the centre of the flap.
- ▶ Set up the controls and show the customer how to operate all the controls shown in the User Guide plus any external controls.
- ▶ Instruct the customer on:
 - the need to re-pressurise the appliance occasionally and the pressure expected at the pressure gauge.
 - location of the filling loop and system pressure gauge.
 - the use of the filling loop and how to re-pressurise the system.
 - how to use the TRVs.
 - how to reset the appliance.
 - if the basic adjust mode is enabled.
- ▶ Show the customer the fault finding information in the User guide.
- ▶ Show the customer where the serial number/appliance information is when they call in with a problem (Benchmark checklist at the rear of the manual).
- ▶ Give the customer details of how to contact the installer/gas emergency numbers.
- ▶ Show the customer how to safely isolate the appliance.
- ▶ Advise the customer where they can find information on the Worcester, Bosch Group website www.worcester-bosch.co.uk.
- ▶ Advise the customer that the varying external temperatures will affect the output of the appliance, especially the DHW.
- ▶ Ensure that the User Guide and Installation, Commissioning and Service manual, with the Benchmark checklist and service record, is left with the appliance or homeowner.
- ▶ If the appliance is unused and exposed to freezing conditions, shut off all the mains supplies and drain the system and appliance, label accordingly.
- ▶ Show the customer the location of the condensate pipe run for external/unheated areas that maybe at risk of prolonged cold temperatures.

6.6.9 Appliance guarantee

This appliance has a guarantee against faulty materials or workmanship for a period from the date of installation subject to the following terms and conditions:

- During the period of this guarantee any components of the appliance which are proven to be faulty or defective in manufacture will be exchanged or repaired free of charge by Bosch Thermotechnology Ltd.
- The householder may be asked to prove the date of installation, that the appliance was correctly commissioned and, where appropriate, the first year's service has been carried out to the satisfaction of Bosch Thermotechnology Ltd., when requested. These should be documented as a part of the Benchmark Checklist.
- The appliance has been used only for the normal domestic purposes for which it was designed.

This guarantee does not affect your statutory rights.

Guarantee registration

Your Greenstar appliance carries a guarantee against faulty material or manufacture subject to Terms and Conditions.

Guarantee Registration can be completed:

- On-line
 - You can register on our website:
www.worcester-bosch.co.uk/guarantee
- By phone
 - You can register by ringing 0330 123 2552
- By post
 - Please send your completed form to:
Worcester, Bosch Group, Cotswold Way, Warndon, Worcester, WR4 9SW.

To read the full Terms & Conditions please visit us on-line at www.worcester-bosch.co.uk/guarantee.

Your statutory rights are not affected by the manufacturer's guarantee.

7 Service and spares



Basic adjust mode

- ▶ Service functions will be disabled if basic adjust mode is enabled. Basic adjust mode will need to be disabled before servicing can be carried out (→ section 6.6.7, page 46).



CAUTION: Mains supplies:

- ▶ Turn off the gas supply and isolate the electrical mains supply before starting any work on the appliance and observe all relevant safety precautions.



CAUTION: Component replacement:

- ▶ After replacement of a gas related component, where a gasket or seal has been disturbed or replaced, check for gas tightness using a gas sniffer/ analyser.
- ▶ Also after re-assembly, carry out the following checks:
Fan pressure → section 6.5.8, page 41,
Flue gas analysis → section 6.5.9, page 41



NOTICE: Service work

- ▶ Service work must be carried out by a competent engineer, such as Gas Safe registered personnel!



NOTICE: Flue gas analyser

- ▶ Service work must not be attempted if a calibrated flue gas analyser and manometer is not available.



NOTICE:

The appliance must be run at maximum output for Fan Pressure test and the Flue Gas analysis.



- To ensure continued efficient operation the appliance must be checked at regular intervals.
- The frequency of servicing will depend upon the particular installation conditions and usage, however, normally an annual service is recommended.
- The extent of the service work required by the appliance is determined by the operating condition of the appliance when tested by qualified engineers.
- After each service, the service interval record sheet at the rear of this manual, must be completed.

7.1 Inspection and service

- ▶ Check that the terminal and terminal guard, if fitted, are unobstructed and undamaged.
- ▶ If the appliance is in a compartment or cupboard, check that the specified service space around the appliance is clear.
- ▶ Check all joints and connections in the system and remake any that show signs of leakage.
Refill and re-pressurise if applicable as described in the commissioning section.
- ▶ Operate the appliance and take note of any irregularities. Refer to the fault finding pages for rectification procedure.

7.1.1 History menu

The History menu function allows information of the last few errors, service reminder requests, burner operation time and burner starts to be accessed, table 41 for details.







- ▶ Press the  button for approximately 5 seconds to enter appliance menu function.
- ▶ Using the DHW up/down arrow buttons to scroll through the menu.
- ▶ Press the  button to select the menu item.
- ▶ Press the  button to leave the info menu.

History Menu list	Description
Locking error history	List of the last eight locking errors
Blocking error history	List of the last five blocking errors
Maintenance request	Displays service maintenance request/s
Operating hours	Displays the number of burner hours for heating and hot water
Burner starts	Displays the number of burner starts for heating and hot water

Table 41 History menu

7.1.2 Test menu

The Test menu function allows some components operation to be checked, table 42 for details.

- ▶ Press the  and  buttons for approximately 5 seconds to enter appliance menu function.
- ▶ Using the DHW up/down arrow buttons to scroll through to the Test menu.
- ▶ Press the  button to select the menu item.
- ▶ Using the DHW up/down arrow buttons to change the status to On.
- ▶ Press the  button to confirm the adjustment.
The test for the component will activate (approximately a 10 second delay before test begins).
- ▶ Once the test is complete
- ▶ Once the test is complete Use the DHW up/down arrow buttons to change the status to OFF.
- ▶ Press the  button to confirm the adjustment.
- ▶ Press the  button to leave the info menu.

Test Menu list	Description
4.t1 - Ignitor test	Component test to check the ignitor operates
4.t2 - Fan test	Component test to check the fan operates
4.t3 - Pump test	Component test to check the pump operates
4.t4 - 3WayValve test	Component test to check the three way valve operates
4.t6 - Ionisation oscillation test	Component test to check flame sense ionisation oscillation function

Table 42 Test menu

7.2 Checking flue integrity



NOTICE:

- ▶ Check flue joints are secure, the terminal and the terminal guard, if fitted are clear and undamaged.

- ▶ Refer to section 6.5.8 and check that the readings conform to those given, confirming flue system and combustion circuit are ok.

7.3 Check the gas inlet pressure



NOTICE:

- ▶ Do not continue with the other checks if the correct gas inlet pressure can not be achieved.

- ▶ Check the gas supply working pressures in the system conform to the readings shown in the table shown in section 6.5.1:

Component access

- ▶ Remove the bottom panel
 - Pull the catch down.
 - Slide the panel forward and down to remove.
- ▶ Removing front case
 - Remove the bottom two screws and pull the bottom of the panel forward slightly.
 - Lift front panel off the two locating lugs on the top of the appliance [1].

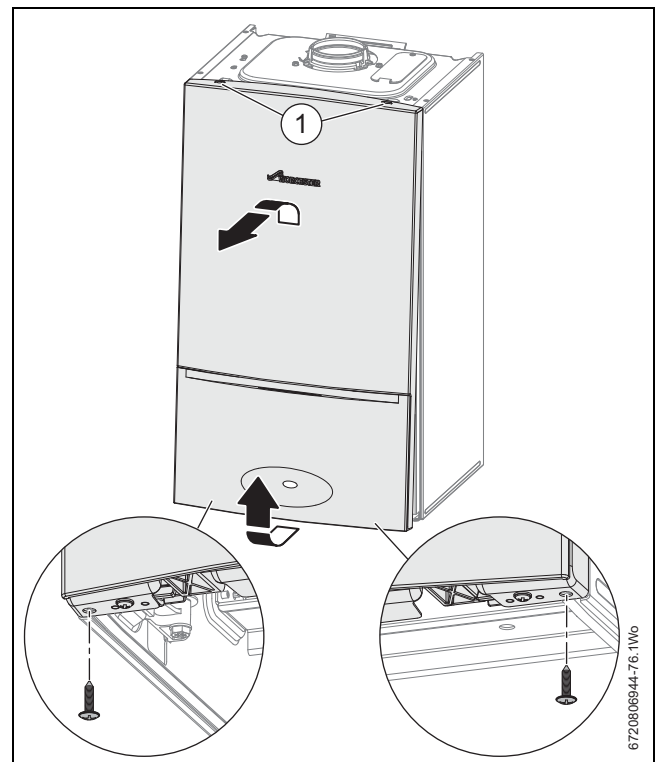

Fig. 65 Remove outer case

7.4 Fan pressure test





This test is to determine if the heat cell requires cleaning or attention.



Service reminder function active:
Setting the appliance to minimum or maximum mode when the service reminder function is active, a service reminder reset notification is displayed h13/H13.

- ▶ Reset the service reminder value in boiler settings menu (→ section 6.5.13, page 43).

Setting the appliance to maximum

- ▶ Set the appliance to maximum output by pressing the  button for at least 5 seconds.
The chimney sweep symbol  will be displayed at the top of the screen and the word "Max" will flash at the bottom of the screen. The appliance will ramp up to maximum output in 30 to 35 seconds.
- ▶ Ensure that the appliance has stabilised at maximum output.



When running at maximum output, and the water temperature is 65°C or less, the appliance will operate both the central heating and DHW circuits with the diverter valve in the mid position. It will be necessary to run sufficient water through the DHW circuit to ensure that the appliance will not cycle on low heating demands. This is to allow sufficient time for the setting procedure. When the water temperature reaches 75°C the diverter valve will switch to CH only.

Fan pressure

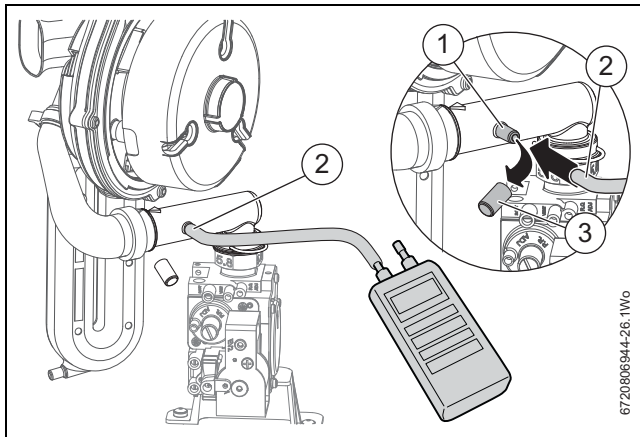

Fig. 66 Fan pressure test point

- ▶ Remove cap [3] and connect the tubing from a digital manometer [2] to the fan pressure test point [1].
- ▶ The pressure will read negative, refer to the chart in figure 67.
- ▶ Replace cap after completing pressure check.

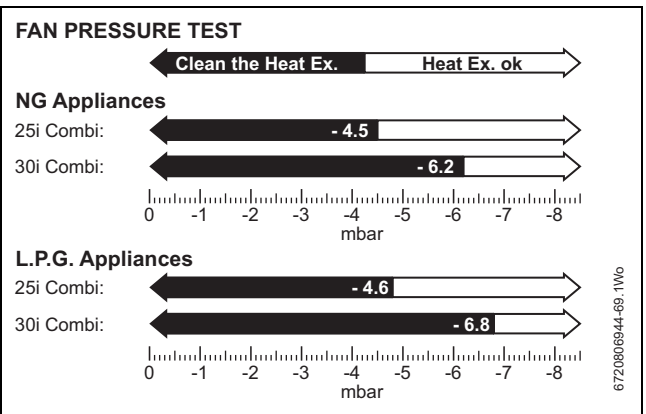



Fig. 67 Fan pressure readings

- ▶ If the manometer reading is in the white area of the chart the heat exchanger/exhaust path/siphon does not require attention.
 - ▶ If the manometer reading is in the black area of the chart then carry out the following checks:
 - Check that the siphon is not blocked.
 - Check the exhaust paths for restrictions.
 - Clean the heat exchanger with a suitable cleaning tool, refer to section 7.6 - Cleaning the heat exchanger.
 - ▶ Re-check the fan pressure readings.
- If the appliance, after completing the above checks, fails the fan pressure test then contact Worcester, Bosch Group for advice.
- ▶ After the measurements are taken switch the appliance off.
 - ▶ Disconnect the manometer and replace the test point cover.
 - ▶ Replace the combustion air intake pipe.

7.5 Flue gas analysis

 **NOTICE:** Combustion testing

- ▶ Combustion testing must be carried out by a competent person. Testing must not be attempted unless the person carrying out the combustion check is equipped with a calibrated Combustion Analyser conforming to BS 7927 and is competent in its use.

 Ensure that the gas inlet pressure is correct before continuing, (→ section 6.5.1).

- ▶ Refer to section 6.5.9 for how to set the appliance to maximum and minimum outputs for the flue gas analysis and check that the readings conform to those given in tables 43 and 44. In addition to the CO and CO/CO₂ ratio checks also check the minimum and maximum CO₂ percentage reading.

NG Appliances		
Output	CO ₂ Reading	CO Reading
Maximum setting (should be measured after 10 minutes)	Between 9.0 and 10.8%	Less than 200ppm
Minimum setting (should be measured after 10 minutes)	Minimum lower than the maximum reading taken but above 8.0% and less than 10.6%	Less than 50ppm

Table 43 NG CO/CO₂ settings

LPG Appliances		
Output	CO ₂ Reading	CO Reading
Maximum setting (should be measured after 10 minutes)	Between 10.2 and 11.8%	Less than 250ppm
Minimum setting (should be measured after 10 minutes)	Minimum lower than the maximum reading taken but above 9.5% and less than 11.6%	Less than 75ppm

Table 44 LPG CO/CO₂ settings

If the CO₂ is out of tolerance then please check:

- ▶ The gas inlet pressure,
- ▶ The gas rate,
- ▶ The fan test pressure,
- ▶ The flue and air intake, plus any possible blockages in the condensate disposal.
- ▶ For leaks or obstructions in the gas way,
- ▶ That the injector is clean.
- ▶ The condition of burner.

After all checks have been and the CO₂ is still out of tolerance then the gas valve must be replaced.

7.6 Cleaning the siphon and heat exchanger

 **NOTICE:** Gaskets

- ▶ The burner and electrode assembly gaskets must be replaced if the air/gas manifold clamping plate is loosened or removed.

 There is an optional tool available to assist in cleaning the heat exchanger, part number 7 733 600 091.

The following items will have to be removed to gain access to the heat exchanger for cleaning:

- ▶ Remove the case.
- ▶ Lower the control panel into the service position.
- ▶ Disconnect electrical wires to the fan, ignition transformer, spark electrodes, flue overheat thermostat, main heat exchanger temperature sensor and flow pipe temperature sensor.
- ▶ Flueway
- ▶ Fan assembly
- ▶ Ignition transformer
- ▶ Spark electrode assembly
- ▶ Burner housing, burner and gasket

Refer to sections 7.7.4 to 7.7.7 for instructions on how to remove the items to gain access to the heat exchanger channels so that the heat exchanger can be cleaned

7.6.1 Cleaning the siphon

Access to the siphon

- ▶ Loosen the captive screw securing the control panel [1].
- ▶ Hinge open the control panel [2] into service position.

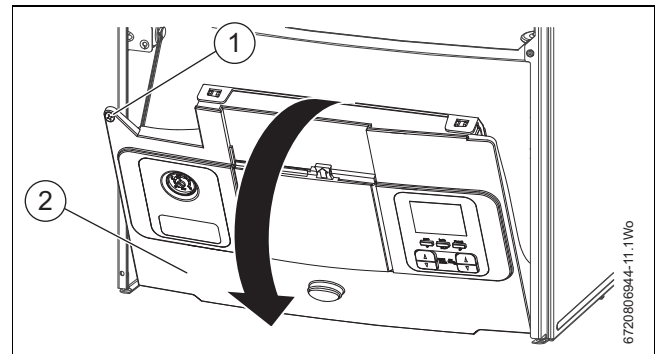

Fig. 68 Access for removing siphon

Removing the siphon

- ▶ Place a suitable container under the siphon and remove the cap to drain the siphon, replace the cap once drained.
- ▶ Remove the siphon securing screw [1] completely.
- ▶ Rotate the siphon [3] level and to the right (until the upper arm [2] is parallel to the side casing), to release from the bayonet connection.
- ▶ Pull the siphon [3] straight down to clear the bayonet connection.
- ▶ Tilt the siphon [3] to the front and remove over the control box assembly [4].
 - Lifting the control box assembly [4] up a little may ease the removal of the siphon.

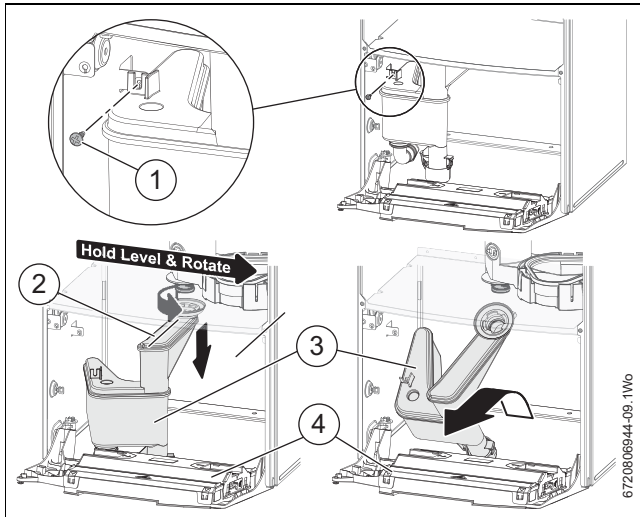

Fig. 69 Removing siphon

- ▶ Visually inspect the siphon to ensure that it is clean and free from debris.

7.6.2 Refitting the siphon after cleaning

- ▶ Fill siphon with 200 to 250 millilitres of water.
- ▶ Slide the siphon in over the control box assembly [2].
 - Lifting the control box assembly [2] up a little may ease the fitting of the siphon.
- ▶ Push the siphon [1] up onto the sump assembly until it fully engages with the sump connection.
- ▶ Rotate the siphon [1] level and to the left to secure the bayonet connection.
- ▶ Push the black discharge hose, onto the condensate outlet pipe.
- ▶ Screw the siphon in position to secure it [3].

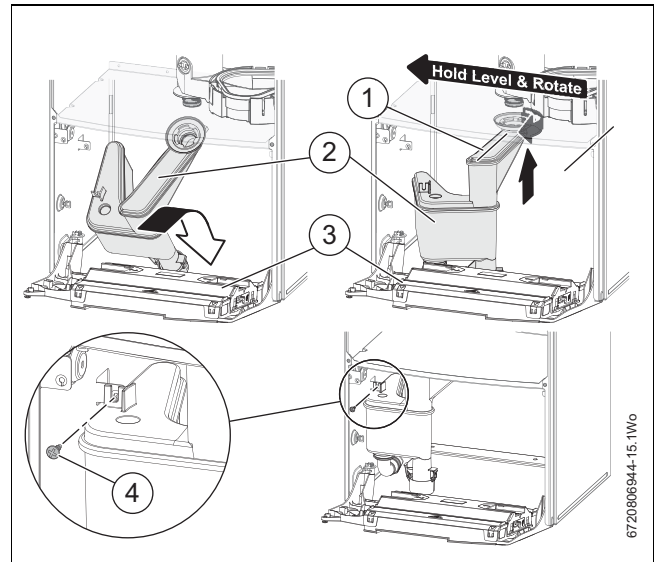

Fig. 70 Reconnecting the siphon

7.6.3 Remove access cover panel

Refer to figure 71.

- ▶ Remove the retaining screw.
- ▶ Lift forward and up to disengage from the retaining lug.

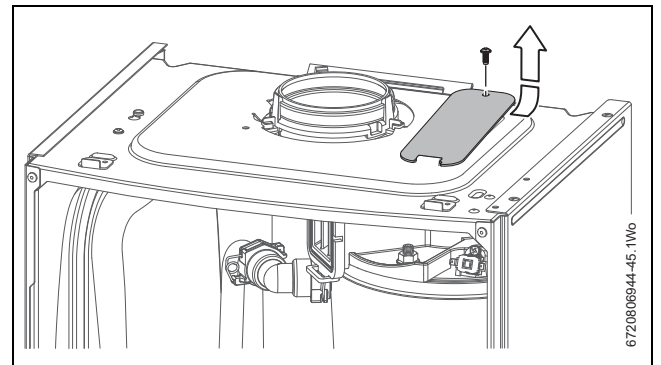

Fig. 71 Access cover plate removal

7.6.4 Cleaning the primary heat exchanger

Refer to figure 72.

- ▶ It is recommended that all channels are cleaned.
- ▶ Remove the siphon and place a suitable container under the outlet to catch the water and debris.
- ▶ Protect the controller from water ingress.
- ▶ Access the heat exchanger flue ways by inserting the cleaning brush (7 733 600 091) through the top access hole in the casing, removal of panel shown in figure 71.
- ▶ Clean heat exchanger flue ways using the cleaning brush removing any debris.
 - The brush must be inserted fully to clean the sump below the heat exchanger.
 - Loosened debris must be flushed from the heat exchanger using clean water.
- ▶ Re-assemble ensuring that the lower baffle and the top baffle are refitted correctly.
- ▶ Refer to figure 79 when re-fitting the burner to ensure that it fits centrally within the heat exchanger and location tabs are situated in location holes.
- ▶ Ensure seal is replaced with new seal and is correctly fitted.
- ▶ Ensure that the clamping plate is properly secured, refer to section 7.7.11 for procedure.
- ▶ Check the siphon unit is clean before refitting to appliance.



The heat exchanger does not have to be removed in order to clean.

The heat exchanger is shown removed from the appliance to illustrate cleaning more clearly.

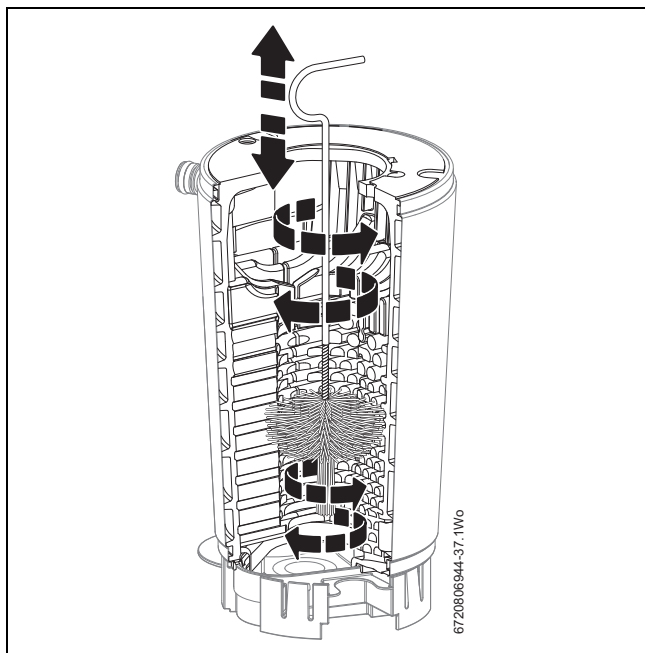

Fig. 72 Cleaning heat exchanger



On completion of the heat exchanger cleaning and re-assembly, perform the fan pressure test as described in section 7.4

7.7 Replacement of parts



CAUTION: Mains supplies:

- ▶ Turn off the gas supply and isolate the mains supplies before starting any work on the appliance and observe all relevant safety precautions.



CAUTION: Component replacement:

- ▶ After replacement of a gas related component, where a gasket or seal has been disturbed or replaced, check for gas tightness using a gas sniffer/ analyser.
- ▶ On re-assembly check all affected seals for cracks, hardness and deterioration. If damaged or in any doubt the seal must be replaced.
- ▶ Also after re-assembly, carry out the following checks:
 - Fan pressure in section 7.4,
 - Flue gas analysis in section 6.5.9.

7.7.1 Component access

- ▶ Removing outer case
 - Remove the bottom panel, pulling down the catch and sliding the panel towards you.
 - Remove the bottom two screws and pull the bottom of the panel forward slightly.
 - Lift front panel off the two locating lugs on the top of the appliance [1].

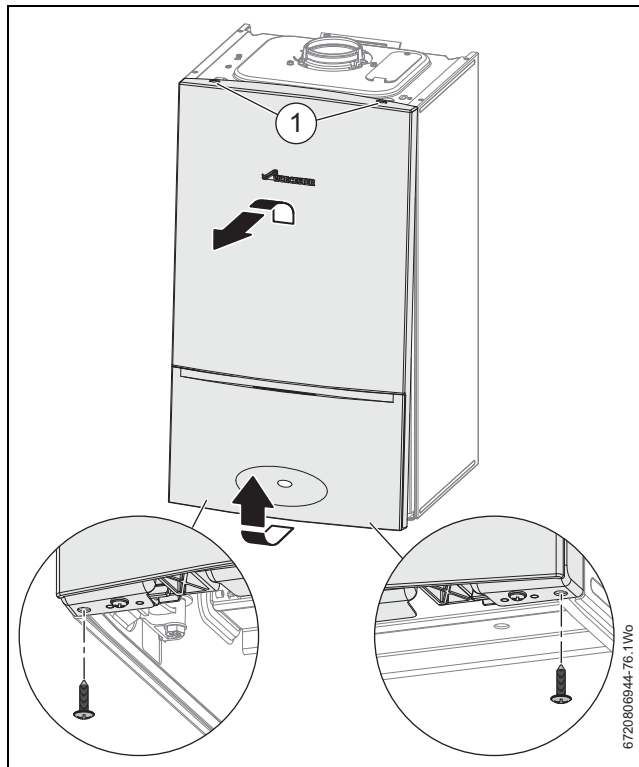

Fig. 73 Remove outer case

7.7.2 Siphon removal replacement of parts

Access to the siphon

Refer to figure 74

- ▶ Release the screw securing the control panel [1].
- ▶ Hinge open the control panel [2] into service position.

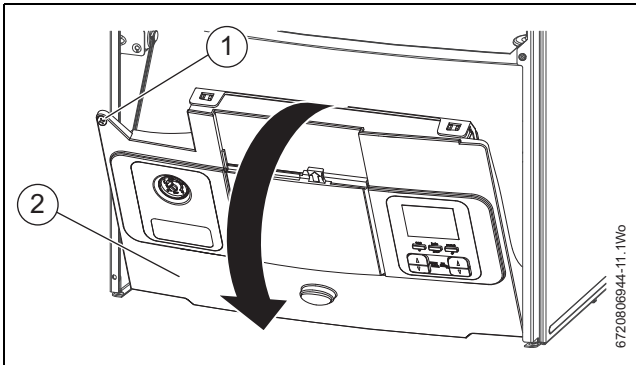

Fig. 74 Access for removing siphon

Siphon removal

Refer to figure 75

- ▶ Place a suitable container under the siphon and remove the cap to drain the siphon, replace the cap once drained.
- ▶ Remove the siphon securing screw [1].
- ▶ Rotate the siphon [2] level and to the right as far as possible to release from the bayonet connection
- ▶ Pull the siphon [2] straight down to clear the connection.
- ▶ Tilt the siphon [2] to the front and remove over the control box assembly [3].
 - Lifting the control box assembly [3] up a little may ease the removal of the siphon.

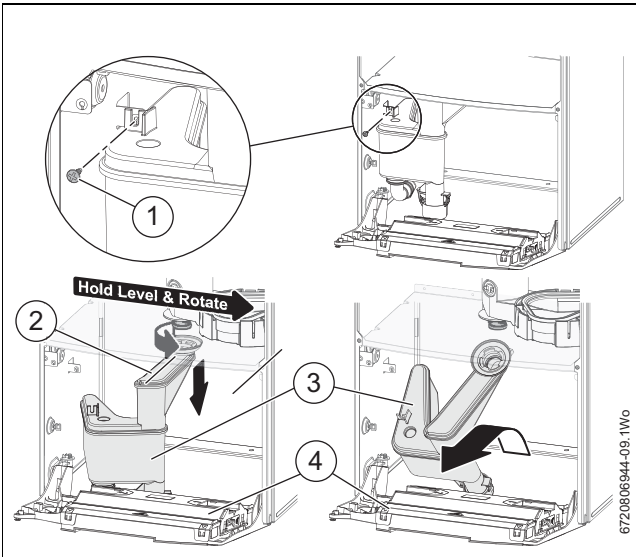

Fig. 75 Removing siphon

- ▶ Once all work has been carried out, refit the siphon (→ section 7.6.2, page 51).

7.7.3 Draining the appliance



NOTICE: Risk of water damage to appliance or property!
Damage from disconnecting water pathways which may have retained some water.

- ▶ Take care after draining appliance to protect equipment/property from residual water content within components.

Many of the tasks in this section require that the appliance be isolated and drained. This will be indicated in the manual if required.

- ▶ Connect a suitable hose firmly to the drain point and run the hose outside to a suitable point or container.
- ▶ Turn the drain valve a ¼ turn anti-clockwise to open the drain. Turn the valve firmly clockwise to close.

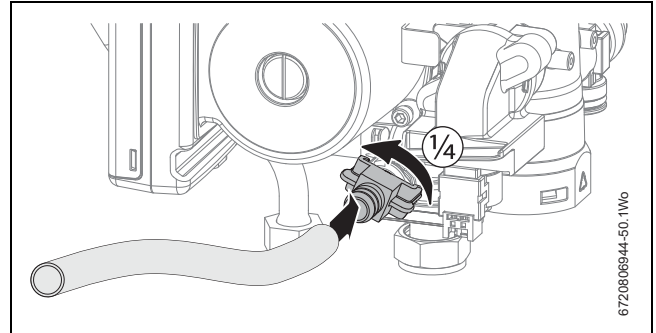

Fig. 76 Draining the appliance

7.7.4 Fan assembly removal

Refer to figure 77

- ▶ Remove electrical connector from fan.
- ▶ Remove wire clip from gas valve outlet.
- ▶ Pull the gas pipe free from the gas valve.
- ▶ Remove securing screw for the fan assembly.
- ▶ Lift the fan assembly out of the location slot.

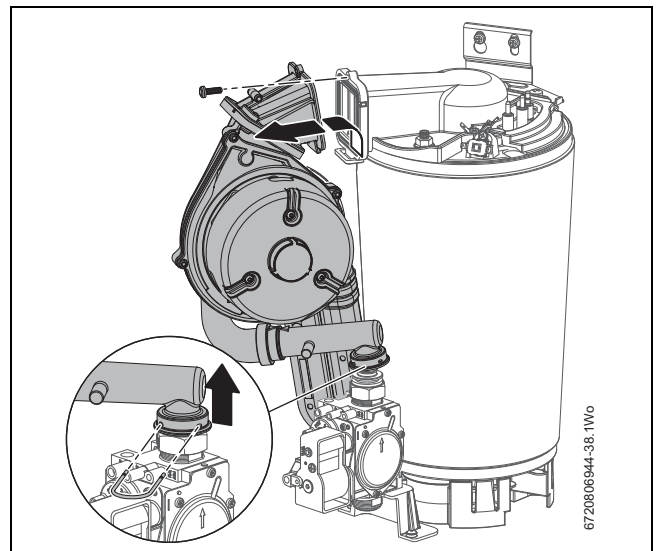

Fig. 77 Fan assembly removal

7.7.5 Air/gas manifold clamping plate removal

Before removing the air/gas manifold clamping plate, the following actions will need to be carried out.

- ▶ Remove electrical connections from the electrode assembly, (→ 7.7.6, Burner and electrode removal).
- ▶ Remove electrical connections from the primary sensor and remove the primary sensor, (→ 7.7.12, Primary sensor (CH NTC)).
- ▶ Remove electrical connections from the overheat thermostat, (→ 7.7.13, Overheat thermostat).

Refer to figure 78.

- ▶ Remove earth connection from the air/gas manifold clamping plate.
- ▶ Undo the securing nut on the heat exchanger.
- ▶ Lift the air/gas manifold clamping plate up and out of the retaining bracket.
- ▶ Refer to section 7.7.11 for refitting instructions.

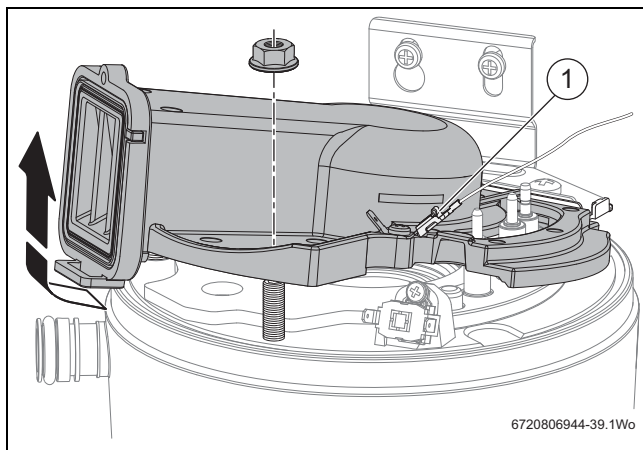

Fig. 78 Air/gas manifold clamping plate removal

7.7.6 Burner and electrode removal

Refer to figure 79

- ▶ Remove electrical connections from the electrode assembly.
- ▶ Remove the air/gas manifold clamping plate as shown in figure 78.
- ▶ Remove spark/flame electrode assembly and seal from the top of the heat exchanger.
- ▶ Remove burner.

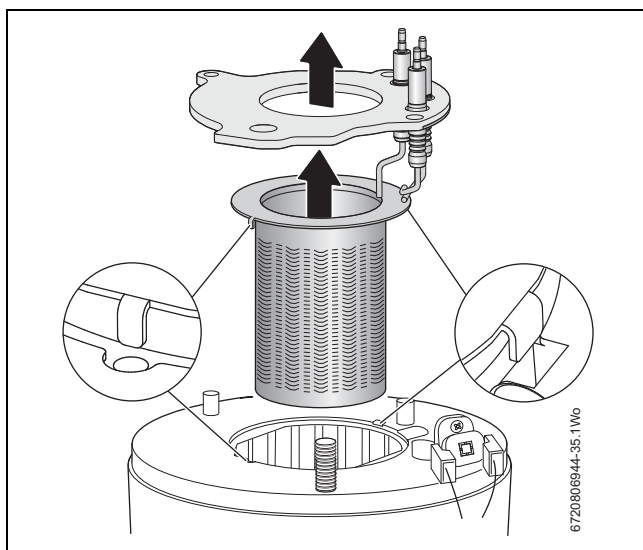

Fig. 79 Burner removal

Checking and cleaning the electrode assembly



NOTICE: Gasket

- ▶ The burner assembly gasket must be replaced if the air/gas manifold clamping plate is loosened or removed.



CAUTION: Component replacement:

- ▶ After replacement of a gas related component, where a gasket or seal has been disturbed or replaced, check for gas tightness using a gas sniffer/ analyser.
- ▶ Also after re-assembly, carry out the following checks:
Fan pressure in section 7.4,
Flue gas analysis in section 7.5.
- ▶ Avoid trapping the primary sensor (CH NTC) clip.

- ▶ Inspect the condition of the electrodes and ceramics, replace if necessary.
- ▶ Use a plastic scouring pad to clean the electrodes.

Burner inspection

- ▶ Inspect the condition of the burner, replace if necessary.
 - Replace burner in correct position, ensure that burner tabs shown in figure 79, fit correctly in their respective locations.

7.7.7 Baffle removal

Refer to figure 80.

- ▶ Remove top baffle.
- ▶ Remove lower baffle.



If the lower baffle is stuck, it may be necessary to use the “baffle removal tool” from the heat exchanger cleaning kit - 7 733 600 091, as shown in figure 80.

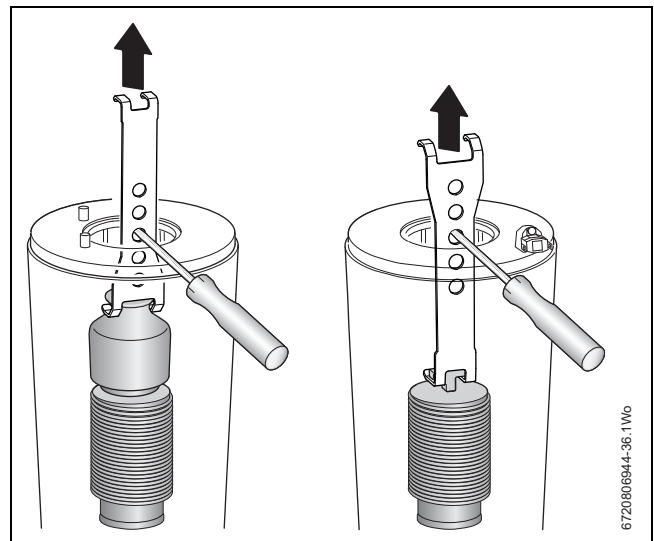

Fig. 80 Baffle removal



Heat exchanger cleaning

- ▶ For cleaning the heat exchanger refer to section 7.6, page 50.

7.7.8 Flow pipe removal

Refer to figure 81.

- ▶ Ensure the appliance is isolated and fully drained.
- ▶ Withdraw the spring clip to release the flow pipe elbow [1] from the heat exchanger.
- ▶ Pull the flow pipe with elbow [1] away from the heat exchanger.

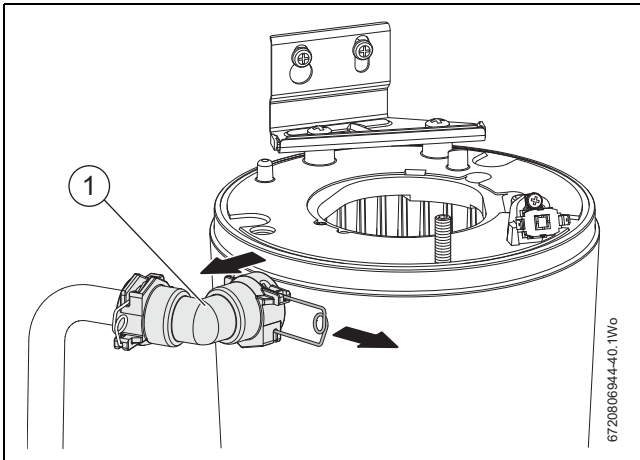

Fig. 81 Flow pipe removal

7.7.9 Exhaust assembly removal

Refer to figures 82 and 83.

- ▶ Remove the three screws securing the flue turret to the top of the appliance.
- ▶ Rotate the upper exhaust support ring [3] anti-clockwise to disengage from the superstructure. The retaining sections [1] slide off the lugs [2], this allows for the upper exhaust assembly to be removed freely.

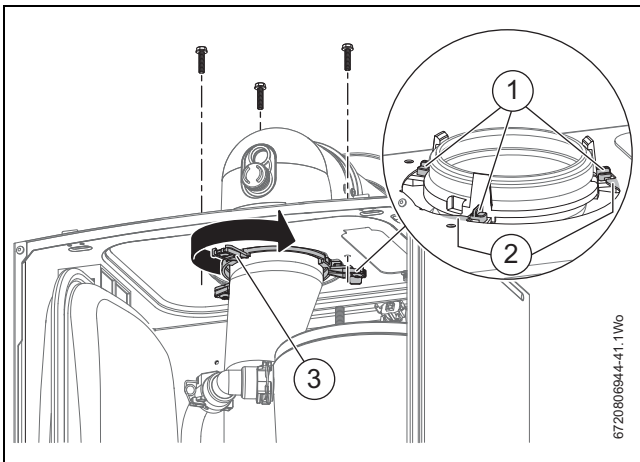

Fig. 82 Upper exhaust assembly disconnection

- ▶ Slide the upper exhaust assembly [4] into the lower exhaust assembly enough to clear the flue exit point in the superstructure.
- ▶ Press the retaining clip [6] to release and lift the exhaust assembly's [4 and 5] from the sump assembly [7].

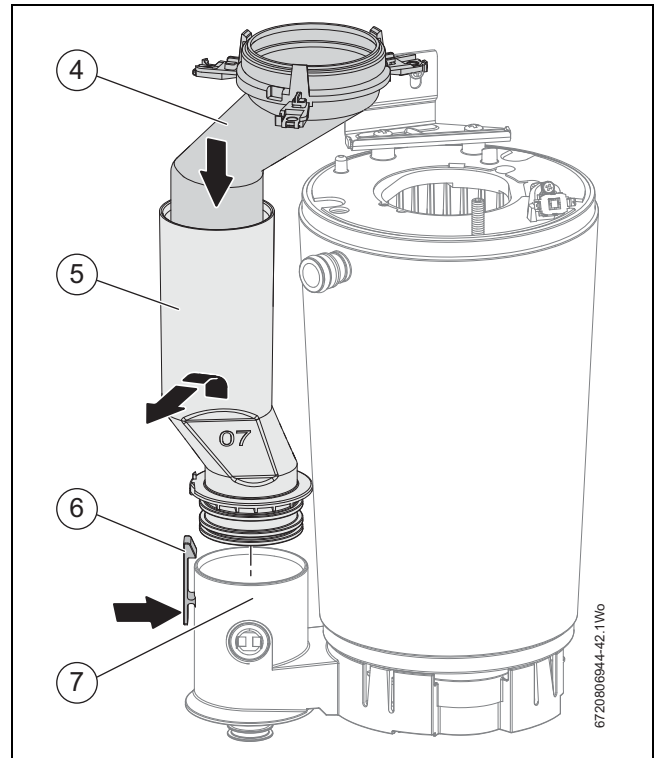

Fig. 83 Upper and lower exhaust assembly removal

7.7.10 Heat exchanger removal

- ▶ Ensure the appliance is isolated and fully drained.
- ▶ Before removing the heat exchanger, the gas valve will need to be removed, (→ section 7.7.17).

Refer to figures 84.

- ▶ Loosen the left heat exchanger retaining screw [1].
- ▶ Remove the right heat exchanger retaining screw [2].
- ▶ Unscrew the plastic sump retaining nut [3].
- ▶ Rotate retaining lever [4] to release the return pipe.
- ▶ Lift the heat exchanger and sump assembly up and out to clear superstructure.

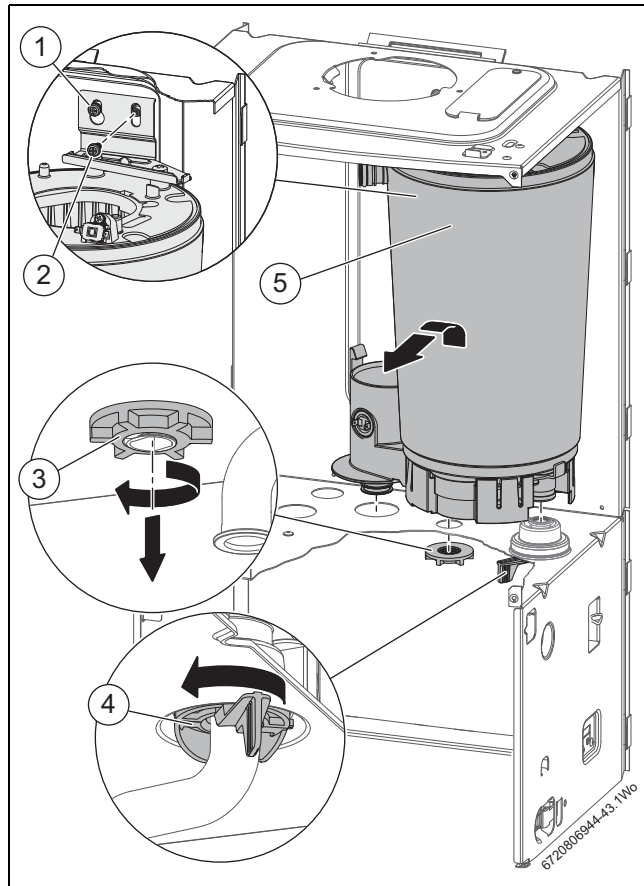

Fig. 84 Heat exchanger removal

7.7.11 Re-assembly of the air/gas manifold clamping plate

NOTICE: Heat exchanger seal

- ▶ If the joint between the Air/Gas manifold and heat exchanger is disturbed the sealing gasket must be replaced.
- ▶ Also after re-assembly, carry out the following checks:
Fan pressure in section 7.4,
Flue gas analysis in section 7.5.

- ▶ Ensure that the new gasket is fitted, with the electrode assembly and gasket heat shield

CAUTION: Clamping plate

- ▶ Ensure that the clamping plate is firmly tightened down on top of the heat exchanger.

Refer to figure 85.

- ▶ Locate the edge of the clamping plate [2] under the bracket [1] and fit the retaining nut [6] hand tight.
- ▶ Initially there will be a gap between the air/gas manifold clamping plate [5] and the top of the heat exchanger [4].
- ▶ Tighten the nut [6] until the underside face of the air/gas manifold clamping plate mates with the top of the heat exchanger [4] as indicated by the two arrows in figure 85.
- ▶ It is important to clamp the plate down firmly, without over tightening, to the heat exchanger to ensure a gas tight seal.

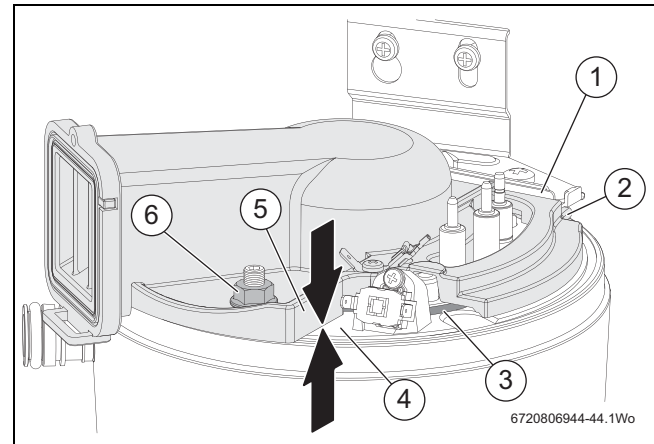

Fig. 85 Air/gas manifold clamping plate fitting

7.7.12 Primary sensor (CH NTC)

Refer to figure 86 for removal.

- ▶ Remove electrical connection by pulling upwards.
- ▶ Squeeze retaining clip [2] on plastic moulding of sensor [1] and pull back and up until clear of pocket in heat exchanger.
- ▶ Pull forward to remove completely.
- ▶ Coat new sensor with heat conductive paste and replace.

7.7.13 Overheat thermostat

Refer to figure 86 for removal.

- ▶ Remove electrical connectors from the overheat thermostat [3].
- ▶ Slacken and remove fixing screw and the overheat thermostat [3].
- ▶ When replacing ensure thermostat sits correctly on surface of the casting with the left hand side of thermostat sitting up against the shoulder.

i It is essential that the mating surface of the thermostat is coated with heat conductive paste.

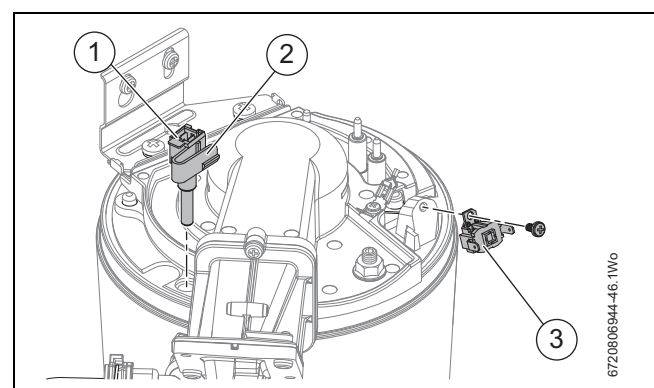

Fig. 86 Primary sensor and overheat thermostat

7.7.14 Spark generator

Refer to figure 87

- ▶ Remove electrical connections.
- ▶ Remove securing screw.
- ▶ Slide spark generator from bracket.
- ▶ When replacing ensure tab locates in bracket retainer before securing spark generator with screw.

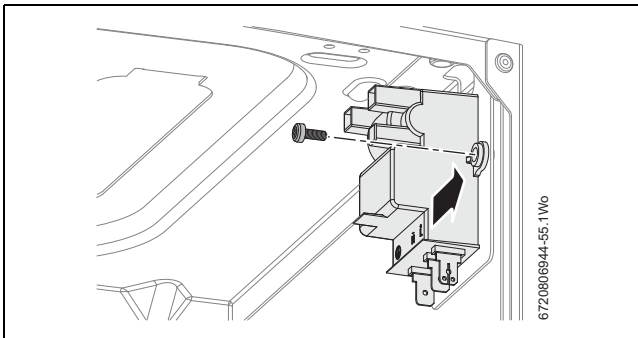

Fig. 87 Remove spark generator

7.7.15 Flue overheat thermostat (with grommet)

To remove and replace the thermostat either:

- ▶ Using a small terminal screwdriver, prise the thermostat and grommet from the plastic housing. Take care not to damage the plastic housing.

-or-

Refer to figure 88.

- ▶ Release the flue connection from the sump.
- ▶ Push the flue tube up.
- ▶ Remove electrical connections.
- ▶ Push the flue limit thermostat [1] out from the sump.

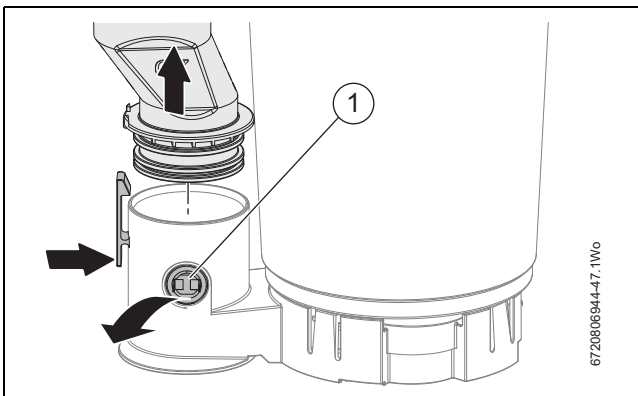

Fig. 88 Remove flue overheat thermostat

To replace, push the thermostat and grommet gently back into the opening until contact with the locating ridge is felt.

7.7.16 Fan

Remove the fan assembly as described in section 7.7.4.

Refer to figure 89

- ▶ Remove two screws retaining the fan to the air/gas manifold [1].
- ▶ Remove the air/gas manifold [1].
- ▶ Remove the gas inlet tube [3].
- ▶ Remove the air inlet tube [4].

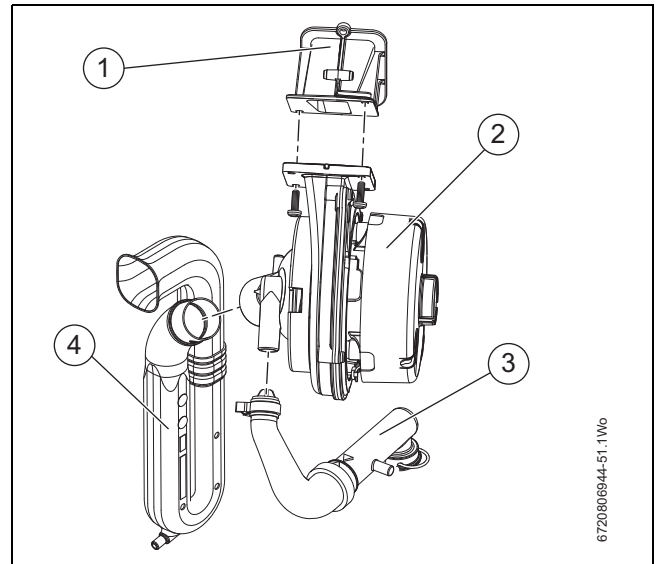

Fig. 89 Dismantling the fan assembly

Refer to figure 90

- ▶ With a terminal screwdriver at the point indicated [7] carefully lever over the stop point [6].
- ▶ Rotate the mixing unit in the direction indicated to release.
- ▶ Remove the mixing unit from the fan.

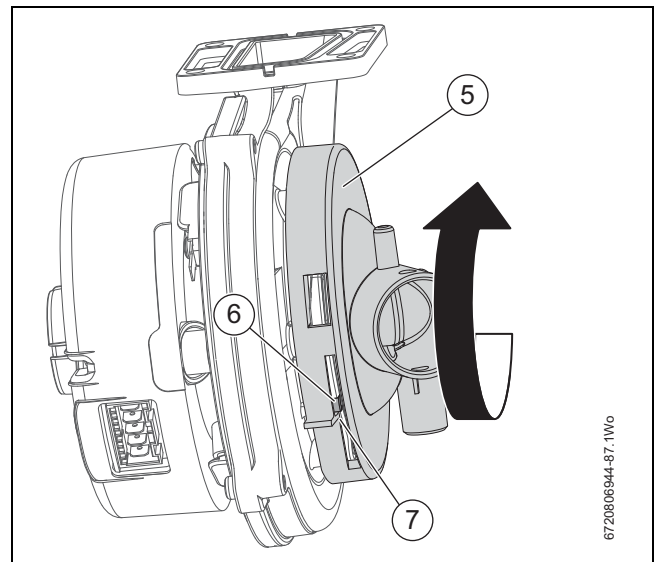

Fig. 90 Mixing unit removal

Re-assemble with new fan ensuring mixing unit and seals are correctly fitted.

7.7.17 Gas valve

Refer to figure 91

- ▶ Isolate gas supply at appliance gas cock.
- ▶ Disconnect the electrical connection from the valve.
- ▶ Remove wire clip [2] from gas valve outlet.
- ▶ Pull the gas pipe [1] free from the gas valve.
- ▶ Undo the bottom gas pipe connection [3].
- ▶ Remove the two screws securing the bracket and remove gas valve from appliance.

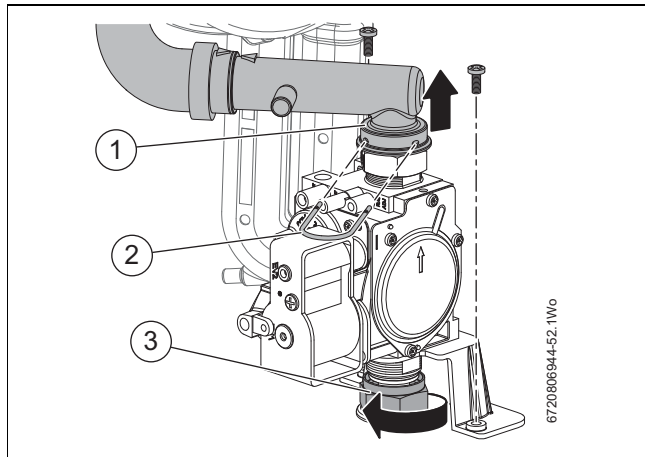

Fig. 91 Gas valve connection

- ▶ When replacing gas valve, fit in reverse order.
- ▶ Fit the new gasket seals on both inlet and outlet of the gas valve.
- ▶ Check all the gas connections for gas tightness.

7.7.18 Expansion vessel removal

Refer to figure 92

- ▶ Ensure the appliance is isolated and fully drained.
 - ▶ Loosen the retaining bracket screws [1], they do not need to be removed.
 - ▶ Undo the connection pipe [2].
 - ▶ Pull the expansion vessel free from the appliance.
- Re-assemble with new expansion vessel ensuring that:
- Align expansion vessel connection with nut ensuring the replacement washer on connection pipe has been fitted.
 - Secure expansion with clamps, taking care not to over tighten the screws.

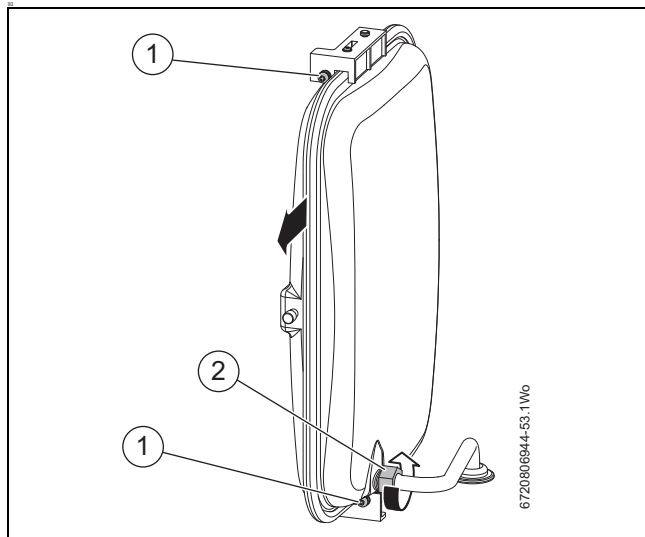

Fig. 92 Expansion vessel removal

7.7.19 PCB fuse

Refer to figure 93

- ▶ Remove fuse holder [1] from the control box housing and replace with a new fuse.
 - A spare fuse is located in a slot in the housing [2].

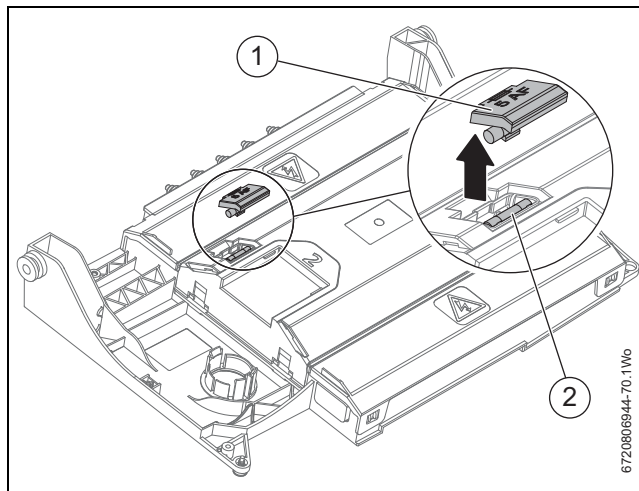

Fig. 93 Fuse location

7.7.20 Replacing control unit



The control unit is supplied within its plastic housing. The complete unit must be replaced. The HCM must be exchanged from the old to the new control unit.

HCM (Heating Control Module) removal

Refer to figure 94

When replacing the control unit [1] the HCM will need to be removed and replaced within the new control unit.

- ▶ Remove the HCM [3] from the control unit.

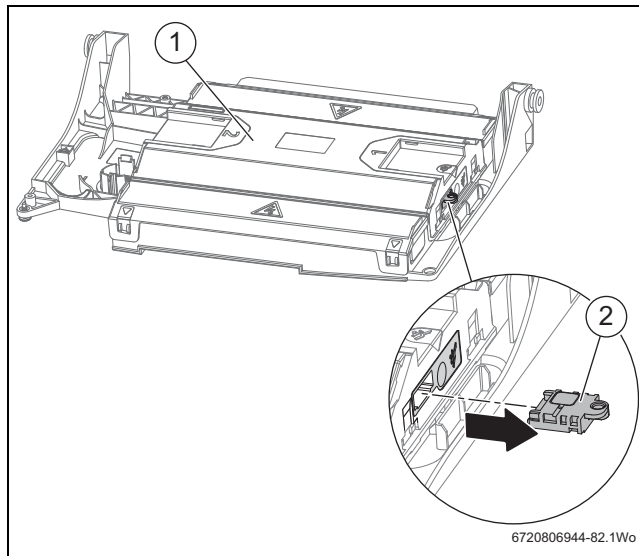

Fig. 94 HCM removal

- ▶ Once the control unit has been replaced insert the HCM into the new control unit.

Pressure gauge indicator and electrical connections removal

Refer to figure 95

- ▶ Pressure gauge indicator removal.
 - Prise the lugs [5] apart to release the gauge indicator from the control box housing.
 - Place the gauge indicator safely out of the way, taking care not to damage or kink the capillary.
- ▶ Remove appropriate cable restraints from the new control unit.
- ▶ Hinge the electrical cover flaps [1] and [2] to allow access to electrical connections.
 - Lift the latches [3] over the catches [4]
 - This will need to be done for the installer connections side [1] and the appliance harness connections side [2].

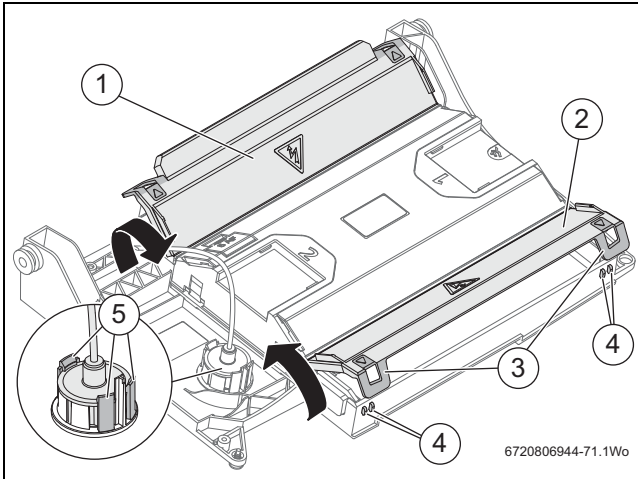

Fig. 95 Access to electrical connections and pressure gauge removal

Control box removal

Refer to figure 96, side panel not shown for clarity.

- ▶ Remove the cable strain relief screw [4].
- ▶ On both sides of the control unit:
 - Remove the retainer securing screw [3].
 - Slide the retainer [1] back and out of the guides [2].
- ▶ Slide the control unit back and out of the guides [2].

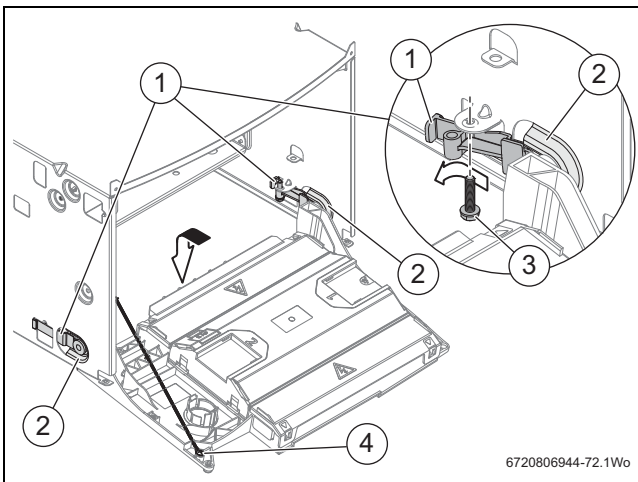

Fig. 96 Support cable connection and control unit removal

- ▶ Replace the new control unit in the reverse order, making sure all connections are secure and properly seated.
- ▶ Make sure the pressure gauge capillary is routed under the main harness.

7.7.21 Hydraulic block components removal



NOTICE: Risk of water damage to appliance or property!
Damage from disconnecting water pathways which may have retained some water.

- ▶ Take care after draining appliance to protect equipment/property from residual water content within components.



Ensure any seals that have been disturbed are renewed.

When working on the hydraulic assembly, ensure that the appliance is isolated and drained.

- ▶ Refer to section 7.7.3 for draining the appliance before proceeding.

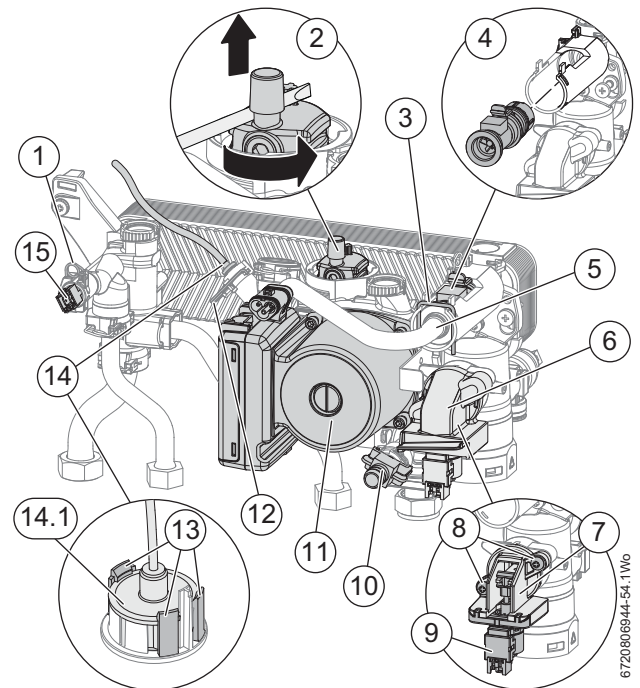

Fig. 97 Hydraulic block

7.7.22 DHW temperature sensor

Refer to figure 97

- ▶ Ensure the domestic hot water circuit is fully drained.
- ▶ Disconnect the electrical connection from the sensor.
- ▶ Withdraw the spring clip [1].
- ▶ Withdraw the sensor from the housing [15].
- ▶ To refit follow the above actions in reverse.

7.7.23 Auto air vent

Refer to figure 97

- ▶ Ensure the appliance is fully drained.
- ▶ Use a screwdriver or similar to rotate the air vent [2] anti-clockwise, lift the air vent out of the housing and remove.



NOTICE:

- ▶ Ensure the old "O" ring is removed before refitting the replacement "O" ring and auto air vent and NOT in the hydraulic block otherwise the Auto air vent will be difficult to fit.
- ▶ Apply silicone lubricant to the "O" ring to ease assembly.

- ▶ To refit, follow the above in reverse.

7.7.24 Flow turbine, flow regulator assembly and filter

Refer to figure 97

- ▶ Ensure the domestic hot water circuit is fully drained.
- ▶ Disconnect the electrical connection from the turbine.
- ▶ Remove the spring clip [3] from the housing and move the brass pipe [5] to one side.
- ▶ Remove the wire mesh filter from the free end of the pipe.
 - Clean thoroughly.
 - Refit the wire mesh filter with the round end first.
- ▶ Withdraw the flow turbine and flow regulator assembly [4] from the housing.
 - **Flow turbine:**
Withdraw the flow turbine from the housing, it may also bring with it the flow regulator assembly.
 - **Flow regulator assembly:**
Using the cartridge tag, withdraw the flow regulator assembly. If the regulator housing has become stuck, a pair of long nosed pliers may be used to grip the housing.
- ▶ Apply silicone lubricant to the seals to ease assembly.
- ▶ To refit, follow the above in reverse. Ensure any seals that have been disturbed are renewed.

Flow regulator

Refer to figure 98

- ▶ Undo the flow regulator assembly housing [4].
- ▶ Using a small Allen key or similar, push the flow regulator cartridge [2] out of the housing.
- ▶ To refit, follow the above in reverse.
- ▶ Ensure any seals that have been disturbed are renewed.

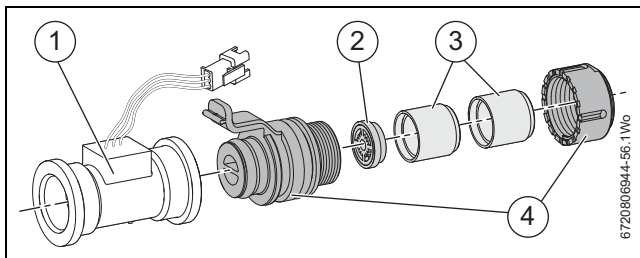

Fig. 98 Flow turbine and flow regulator assembly parts

- [1] Flow turbine
- [2] Flow regulator (colour varies depending on output)
- [3] Silencers
- [4] Flow regulator assembly housing

7.7.25 Diverter valve motor



The appliance does not have to be drained to remove the diverter valve motor.

- ▶ Enter service mode to ensure that the diverter valve is in mid position.
- ▶ Electrically isolate the appliance.

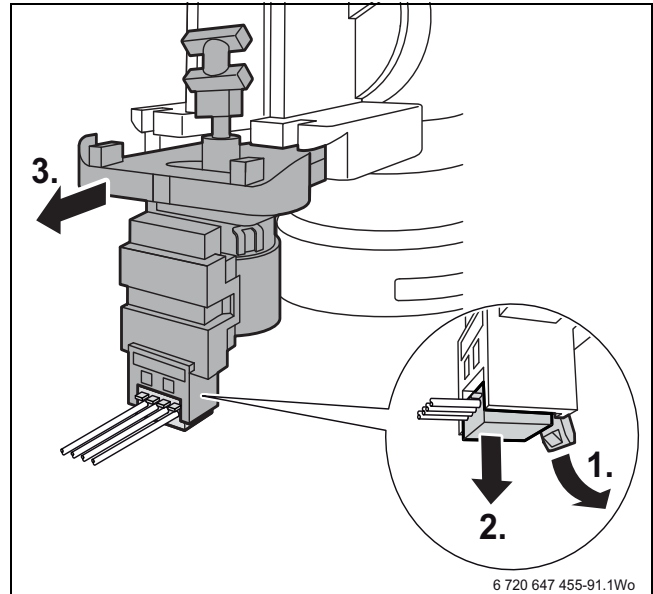

Fig. 99 Diverter valve motor removal

Refer to figure 99

- ▶ Release the tab [1] and pull the electrical connector down [2] to disconnect the diverter valve motor.

Refer to figure 97

- ▶ Remove the protective cover [6].
- ▶ Pull the diverter valve motor [9] from the housing.
- ▶ Re-fit the diverter valve motor, slide the motor into the housing.
- ▶ Ensure that "H" section of the motor actuator is fitted correctly into valve body.
- ▶ Re-connect the electrical connection.
- ▶ Re-fit the protective cover.



In case of problems when refitting the motor: Connect the electrical connector to the motor and switch the appliance on. Then the motor goes to the middle position and you can refit it without difficulty.

7.7.26 Diverter valve



Ensure the appliance is fully drained before removing the diverter valve.

To ease assembly of components, apply silicone lubricant to sealing surfaces.

- ▶ Enter the service mode to ensure that the diverter valve is in mid position (there is no need to drain the appliance).
- ▶ Electricity isolate the appliance.

Refer to figure 99

- ▶ Disconnect the electrical connector from the diverter valve motor by releasing the tab [1] and pulling the electrical connector down [2].

Refer to figure 97

- ▶ Remove the protective cover [6].
- ▶ Pull the diverter valve motor [9] from the housing.
- ▶ Undo the two screws [8] from the diverter valve housing [7].
- ▶ Withdraw the diverter valve housing [7] and clean the valve chamber if necessary.
- ▶ To re-fit, follow the above in reverse.

7.7.27 Drain tap

Refer to figure 97

- ▶ Rotate the drain tap [10] fully anti-clockwise and push in.
- ▶ Withdraw the drain tap from its housing.

7.7.28 Pump head

Refer to figure 97

- ▶ Disconnect the electrical connections from the pump.
- ▶ Remove the four screws securing the pump head.
- ▶ Pull the pump head [11] from the housing.

7.7.29 Pressure gauge

Refer to figure 97

- ▶ Prise the lugs [13] apart to release the gauge.
- ▶ Remove the gauge [14.1] taking care not to damage or kink the capillary.
- ▶ Un-clip the capillary tube from the retainers on the left hand side of the lower structure.
- ▶ Withdraw the spring clip [12] from the pressure sensing head housing.
- ▶ Remove the pressure sensing head [14] and pressure gauge capillary from the housing.
- ▶ To re-fit follow the above in reverse. DO NOT omit the "O" ring from the capillary when fitting a replacement gauge.

7.7.30 DHW pressure relief valve

Refer to figure 100

- ▶ Disconnect all pipes connected to the pump housing. Remove the electrical connection to the pump.
- ▶ Remove the metal clip to the right of the pump head to release the pump housing.
- ▶ Slide the pump housing to the left and withdraw from the appliance.
- ▶ Remove the spring clip from the pressure relief valve housing.
- ▶ Withdraw the pressure relief valve.

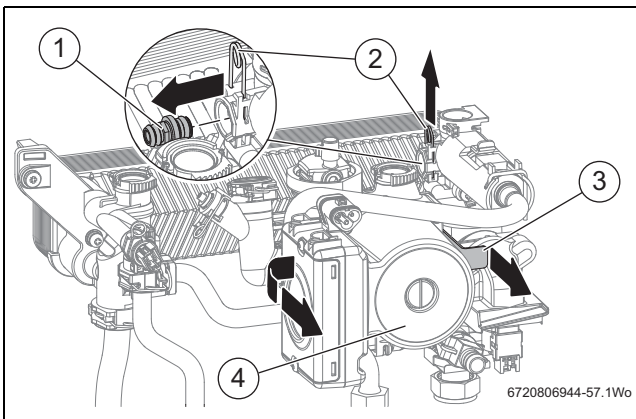

Fig. 100 DHW pressure relief valve

7.7.31 Hydraulic block removal

- ▶ Remove the Siphon assembly, refer to Siphon removal page 53.

Refer to figure 101

- ▶ Disconnect the electrical connections to the NTC sensor, turbine and pump.
- ▶ Undo the nuts securing the copper water pipes to the manifold (there is no need to remove the gas pipe).
- ▶ Remove the siphon.
- ▶ Release the spring clip [2] securing the expansion vessel pipe to the plastic housing and remove the pipe.
- ▶ Release the spring clip [3] securing the pressure gauge sensing head to the plastic housing and remove the sensing head.
- ▶ Release the locking devices that secure the two copper water pipes leading to the combustion chamber by squeezing the two tabs together and rotating anti-clockwise (viewed from above).

- ▶ Lower the pressure relief connector by pulling the lever forward and down.
- ▶ Undo the two screws [1] securing the hydraulic block to the chassis (located top left / top right of the housing).
- ▶ Lift the left hand side of the block slightly.
- ▶ Manoeuvre the block out, starting at the right hand side.
- ▶ Take care not to snag the harness.



The block will still contain an amount of water, which will spill out if the block is tilted.

- ▶ To refit, follow the above in reverse. Ensure any seals that have been disturbed are renewed.

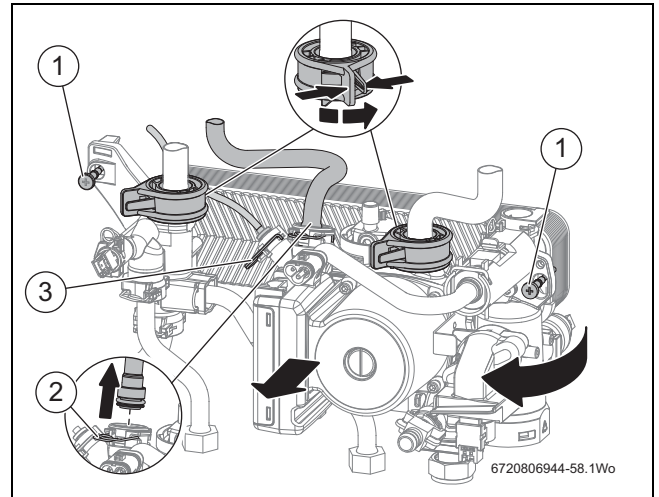

Fig. 101 Hydraulic block removal

7.7.32 CH pressure relief valve

Refer to figure 102

- ▶ Remove the hydraulic block from the appliance (See 7.7.31 Hydraulic block removal).
- ▶ Release the spring clip [2] from the Pressure Relief Valve housing.
- ▶ Withdraw the Pressure Release Valve [1] from its housing.

7.7.33 Bypass valve

Refer to figure 102

- ▶ Remove the hydraulic block from the appliance (See 7.7.31 Hydraulic block removal).
- ▶ Remove the spring clip [5] (on the left hand plastic housing to the heat exchanger) of the copper bypass pipe [3].
- ▶ Undo the screw [4] securing the left hand plastic housing to the heat exchanger.
- ▶ Move the housing to the left to free up the one end of the pipe.
- ▶ Remove the spring clip [8] (on the right hand plastic housing) of the copper bypass pipe [3].
- ▶ Remove the pipe [3] from the right hand housing to reveal the bypass valve [7]. Taking care not to lose the bypass pipe restrictor [6] from inside the bypass pipe [3].
- ▶ Using a pair of pliers, pull out the bypass valve from the housing
- ▶ To refit, follow the above in reverse. Ensure any seals are renewed.

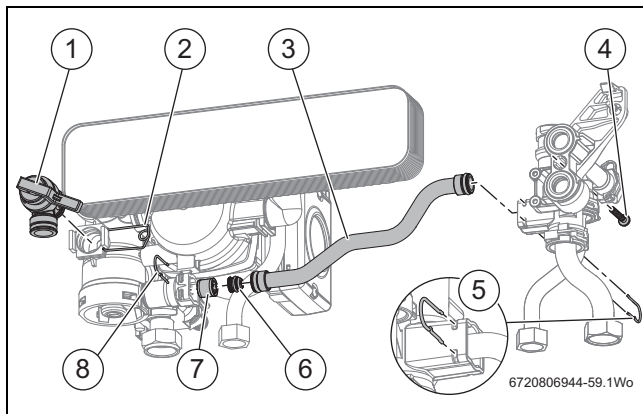

Fig. 102 PRV and bypass valve removal

7.7.34 DHW plate heat exchanger

Refer to figure 103

- ▶ Remove the hydraulic block from the appliance (See 7.7.31 Hydraulic block removal).
- ▶ Undo the two screws securing the plastic housing to the heat exchanger.
- ▶ Remove the heat exchanger
- ▶ To refit, follow the above in reverse.
- ▶ Ensure any seals that have been disturbed are renewed.

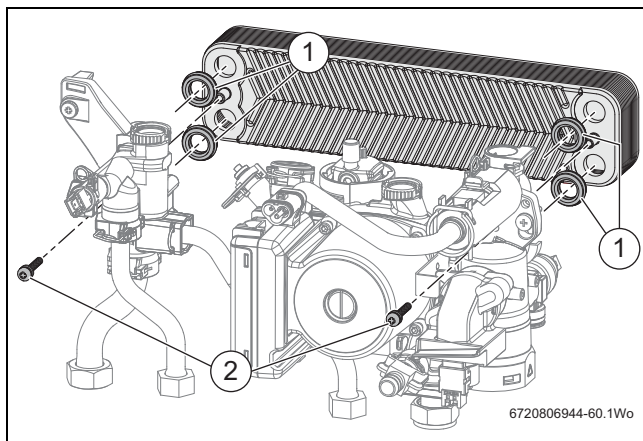

Fig. 103 DHW plate heat exchanger removal

7.8 Short parts list



Only use Worcester original spare parts with this appliance. Non Worcester original spare parts will invalidate the guarantee (if applicable) and any warranty.





























	Gasket - burner 8 716 110 534 0		Electrodes (including gasket & shield) 8 718 107 087 0
	O ring - siphon 8 716 113 851 0		Burner 8 718 120 619 0
	Fuse 8 716 116 900		Siphon 8 716 117 083
	Spark generator 8 716 117 077		Gas valve 8 718 600 04A 0
	High limit stat 8 707 206 196 0		Flue overheat thermostat 8 710 506 267 0
	Flow NTC 8 714 500 087 0		Fan 8 716 117 417
	Pump assembly 8 716 117 400		Auto air vent 8 716 106 445 0
	Pressure relief valve 3 bar 8 716 106 431 0		Expansion vessel 8 716 117 023
	Control panel 8 716 117 070		By pass valve 8 716 106 434 0
	Pressure gauge 8 76 116 428 0		Diverter valve assembly 8 716 117 405
	Diverter valve motor 8 718 682 839 0		Flow turbine 8 716 107 223 0
	Flow regulator 9 litre E-W LP orange (25kW) 8 718 690 708 0		Flow regulator 11 litre E-W LP brown (30kW) 8 718 684 213 0
	Heat exchanger 10 plate (25kW) 8 716 106 686 0		Heat exchanger 16 plate (30kW) 8 716 106 685 0
	DHW NTC 8 714 500 081 0		Pressure relief valve DHW 8 717 401 029 0

Table 45 Parts list

8 Fault finding and diagnosis

8.1 Fault finding



This fault finding information is for guidance only. Worcester cannot be held responsible for costs incurred by persons not deemed to be competent.

Should a fault develop with this appliance (or the system), the appliance will enter a locking or blocking condition, and fault code information will be generated as described in this section.

Locking error	The appliance display will flash a warning triangle and fault code. At the same time a (static) cause code will also be displayed. Manual intervention is required following clearance of the fault: <ul style="list-style-type: none"> ▶ Press the reset button briefly once on the appliance facia • The last eight locking errors can be found in the History menu (→ section 7.1.1, page 48).
Blocking error	The appliance will stop operating with no fault data displayed. The condition will clear automatically when the associated fault clears e.g. waiting for an area to cool. In some cases a blocking error has a defined time duration prior to changing to a locking condition. <ul style="list-style-type: none"> • The last eight blocking errors can be found in the History menu (→ section 7.1.1, page 48).
Fault code	Alpha numeric code indicating the fault group
Cause code	Three digit number. During a blocking error (or normal operating status) it is not displayed, but accessed in the info menu via the spanner/return button. During a locking error the cause code flashes on the display.
Maintenance codes	These are displayed with the letter H followed by a number. The code advises of a situation that will need some attention but is not a fault that will stop the appliance from functioning. <ul style="list-style-type: none"> • The maintenance messages can be found in the History menu (→ section 7.1.1, page 48). • Two examples are listed below:
H09	Communications to the pump has failed. The feedback signal has been lost, possible causes are electrical connections loose or disconnected, pump has been replaced with an incorrect type.
H13	A time has been set in the Service interval function i.e. 1 to 72 months and that time has expired. Service reminder time in the Boiler settings menu (section 6.5.13, page 43) allows this feature to be set (1 to 72), a 0 will disable this function.

Table 46



Resistance values

- ▶ Component resistance characteristics can be found in section 8.2, page 69.
 - Flow temperature NTC sensor
 - DHW NTC sensor
 - Flue overheat thermostat
 - Overheat thermostat
 - Outdoor weather compensation sensor
 - Gas valve

8.1.1 Maintenance Menu

Display text	Cause code	Description	Possible cause/check
No service request	H--	No maintenance request messages available.	There are no more maintenance messages available
Planned maintenance required	H03	The number of operating hours set for service interval has expired. <ul style="list-style-type: none"> • This will appear on the appliance display screen. • Can also be accessed in the maintenance menu. 	This message will only be available if burner hours service option has been enabled in intelligent controller. <ul style="list-style-type: none"> ▶ Reset maintenance message, (press reset button). ▶ Carry out a service and reset the service reminder.
burner hours set	h03	The number of operating hours set for service interval has not been reached at the time the maintenance menu messages are accessed.	This message will only be available if burner hours service option has been enabled in intelligent controller. <ul style="list-style-type: none"> ▶ Reset maintenance message, press reset button. ▶ If a service has been carried out at visit, reset the service reminder.
	H08	The set interview date has expired. Maintenance required. <ul style="list-style-type: none"> • This will appear on the appliance display screen. • Can also be accessed in the maintenance menu. 	This message will only be available if burner hours service option has been enabled in intelligent controller. <ul style="list-style-type: none"> ▶ Reset maintenance message, (press reset button). ▶ Carry out a service and reset the service reminder.
Service date set	h08	Confirmation of service date.	This message will only be available if burner hours service option has been enabled in intelligent controller. <ul style="list-style-type: none"> ▶ Reset maintenance message, (press reset button).
Pump communications error	H09	Communications to the pump has failed.	▶ Check: <ul style="list-style-type: none"> – Electrical connections are fitted correctly. – Correct pump has been fitted. – Once checked, re power the appliance for test of communications.
Hot water flow sensor defect	H11	DHW temperature sensor defect.	▶ Check: <ul style="list-style-type: none"> – Sensor harness and connector. – Operation, replace if necessary.
	H13	The maximum maintenance interval set (in months), has exceeded or after the appliance has been placed into commissioning mode. <ul style="list-style-type: none"> • This will appear on the appliance display screen. • Can also be accessed in the maintenance menu. 	▶ Reset maintenance message, (press reset button). ▶ Carry out a service and reset the service reminder. <ul style="list-style-type: none"> – Service reminder is set in boiler setting 2.5F (→ section 6.5.13, page 43). – Service reminder function details (→ section 6.5.10, page 42).
Number of months set	h13	The maximum maintenance interval set (in months), has not been reached or after the appliance has been placed into commissioning mode.	▶ Reset maintenance message, (press reset button). ▶ If a service has been carried out at visit, reset the service reminder. <ul style="list-style-type: none"> – Service reminder is set in boiler setting 2.5F (→ section 6.5.13, page 43). – Service reminder function details (→ section 6.5.10, page 42).
	H29	Outdoor sensor defect (available when accessory outdoor sensor is connected)	▶ Check: <ul style="list-style-type: none"> – Sensor harness and connector. – Operation, replace if necessary.

Table 47

8.1.2 Error codes

Display text	Fault code	Cause code	Description	Possible solution/check
		226	Service tool has been connected	In the blocking error history menu it records if the service tool has been connected
Electrical interruption fault	Fd	231	The power has been interrupted during a lockout	<ul style="list-style-type: none"> ▶ Check locking error history: <ul style="list-style-type: none"> - Lockout fault will always be last code before FD code. ▶ Reset the appliance
Fan/Airflow fault	C7	214	Fan does not run during the start up phase	<ul style="list-style-type: none"> ▶ Check: <ul style="list-style-type: none"> - Fan harness and connector. - 230 Vac across brown and blue wires. - Fan operation, replace if necessary. - Connections of the control box. ▶ Replace control box if necessary.
Fan/Airflow fault	C6	215	Fan speed too high	<ul style="list-style-type: none"> ▶ Check: <ul style="list-style-type: none"> - Fan harness and connector. - Fan operation, replace if necessary. - Connections of the control box. ▶ Replace control box if necessary.
Fan/Airflow fault	C6	216	Fan speed too low	<ul style="list-style-type: none"> ▶ Check: <ul style="list-style-type: none"> - Fan harness and connector. - Fan operation, replace if necessary. - Connections of the control box. ▶ Replace control box if necessary.
Fan/Airflow fault	C7	217	Fan has stopped during appliance operation	<ul style="list-style-type: none"> ▶ Check: <ul style="list-style-type: none"> - Fan harness and connector. - 230 Vac across brown and blue wires. - Fan operation, replace if necessary. - Connections of the control box. ▶ Replace control box if necessary.
Fan/Airflow fault	C1	264	Fan stopped during operation	<ul style="list-style-type: none"> ▶ Check: <ul style="list-style-type: none"> - Fan harness and connector. - 230 Vac across brown and blue wires. - Operation, replace if necessary.
Fan/Airflow fault	C4	273	Continuous fan operation for the last 24 hours (appliance temporary blocked)	▶ Check if demand has been calling for the 24 hours. Appliance has been blocked from firing for a minimum of 2 minutes as it has been operated continuously for 24 hours.
Flow sensor fault	E2	222	Flow temperature sensor shorted	<ul style="list-style-type: none"> ▶ Check: <ul style="list-style-type: none"> - Sensor harness and connector. - Operation, replace if necessary.
Flow sensor fault	E2	223	Flow temperature sensor disconnected	<ul style="list-style-type: none"> ▶ Check: <ul style="list-style-type: none"> - Sensor harness and connector. - Operation, replace if necessary.
Flow sensor fault	E9	276	Primary Flow temperature exceeded 95 °C	<ul style="list-style-type: none"> ▶ Check: <ul style="list-style-type: none"> - Primary system water pressure. - For air in the system - Circulation within heating system. - Wiring and operation of the pump and flow temperature sensor, replace part/s if necessary.
Flow sensor fault	E2	350	Flow temperature sensor shorted	<ul style="list-style-type: none"> ▶ Check: <ul style="list-style-type: none"> - Sensor harness and connector. - Operation, replace if necessary.
Flow sensor fault	E2	351	Flow temperature sensor disconnected	<ul style="list-style-type: none"> ▶ Check: <ul style="list-style-type: none"> - Sensor harness and connector. - Operation, replace if necessary.

Table 48

Display text	Fault code	Cause code	Description	Possible solution/check
Gas valve fault	FA	306	Ionisation detected after the gas valve closed.	<ul style="list-style-type: none"> ▶ Inspect the ionization probe, replace if necessary. ▶ Check that the condensate is discharging. ▶ Check 230Vac across blue & orange wires to the coils. <ul style="list-style-type: none"> – Replace gas valve if no voltage. – Replace control box if there is voltage.
Ignition/Ionisation fault	EA	227	No ionisation detected after ignition	<ul style="list-style-type: none"> ▶ Check: <ul style="list-style-type: none"> – The dynamic gas pressure. – The flue system for restrictions. – The gas-air ratio (if possible). – Connectors of the ignition unit. – Ignition and ionisation current. – Ignition unit for damage or wear, replace if necessary. – Gas valve operation. – Appliance for contamination. – Blocked condensate pipes.
Ignition/Ionisation fault	F7	228	Ionisation current detected before burner-start	<ul style="list-style-type: none"> ▶ Check: <ul style="list-style-type: none"> – Condition of the ionisation probe. – Connection of the ionisation probe. – Condensate is discharging correctly. – Replace parts if necessary.
Ignition/Ionisation fault	EA	229	Loss of ionisation signal during operation	<ul style="list-style-type: none"> ▶ Check: <ul style="list-style-type: none"> – The gas-air ratio. – The dynamic gas. – Wiring and connection of flame probe. – Replace flame probe necessary. – Blocked condensate pipes.
Ignition/Ionisation fault	EA	261	HCM potentially defective	<ul style="list-style-type: none"> ▶ Reset the appliance. If continues to go to this error ▶ Check: <ul style="list-style-type: none"> – HCM is inserted properly. – HCM number. – For blocked condensate pipes. ▶ Contact technical helpline.
Internal error	9U	233	Control box or HCM is defective or loose	<ul style="list-style-type: none"> ▶ Check: <ul style="list-style-type: none"> – HCM is inserted properly. – Replace HCM if necessary. – Connections of the control box. ▶ Replace control box if necessary.
Internal error	C4	237	Control box or the HCM is defective.	<ul style="list-style-type: none"> ▶ Check: <ul style="list-style-type: none"> – HCM is inserted properly. – Replace HCM if necessary. – Connections of the control box. ▶ Replace control box if necessary.
Internal error	F0	238	Gas valve or control box error	<ul style="list-style-type: none"> ▶ Check: <ul style="list-style-type: none"> – Gas valve coils: 230V ac across blue & orange wires. – Replace gas valve if necessary. – Connections of the control box. ▶ Replace control box if necessary.
Internal error	F0	239	Control box or the HCM is defective.	<ul style="list-style-type: none"> ▶ Check: <ul style="list-style-type: none"> – HCM is inserted properly. – Replace HCM if necessary. – Connections of the control box. ▶ Replace control box if necessary.

Table 48

Display text	Fault code	Cause code	Description	Possible solution/check
Internal error	F0	242 - 256	Control box or the HCM is defective.	<ul style="list-style-type: none"> ▶ Check: <ul style="list-style-type: none"> - HCM is inserted properly. - Connections of the control box. ▶ Contact technical helpline.
Internal error	b7	257	Control box or the HCM is defective.	<ul style="list-style-type: none"> ▶ Check: <ul style="list-style-type: none"> - HCM is inserted properly. - Connections of the control box. ▶ Contact technical helpline.
Internal error	F0 EH	258 258	Control box or the HCM is defective.	<ul style="list-style-type: none"> ▶ Check: <ul style="list-style-type: none"> - HCM is inserted properly. - Connections of the control box. ▶ Contact technical helpline.
Internal error	F1	259	Control box or the HCM is defective.	<ul style="list-style-type: none"> ▶ Check: <ul style="list-style-type: none"> - HCM is inserted properly. - Connections of the control box. ▶ Contact technical helpline.
Internal error	F0	262	Control box or the HCM is defective.	<ul style="list-style-type: none"> ▶ Check: <ul style="list-style-type: none"> - HCM is inserted properly. - Connections of the control box. ▶ Contact technical helpline.
Internal error	F1	263	Control box or the HCM is defective.	<ul style="list-style-type: none"> ▶ Check: <ul style="list-style-type: none"> - HCM is inserted properly. - Connections of the control box. ▶ Contact technical helpline.
Internal error	F0	272	Control box or the HCM is defective.	<ul style="list-style-type: none"> ▶ Check: <ul style="list-style-type: none"> - HCM is inserted properly. - Replace HCM if necessary. - Connections of the control box. ▶ Replace control box if necessary.
Internal error	F0	280	Control box is defective.	<ul style="list-style-type: none"> ▶ Check: <ul style="list-style-type: none"> - HCM is inserted properly. - Connections of the control box. ▶ Replace control box if necessary.
Internal error	F0	290	Control box is defective, (Analogue / Digital converter reference error).	<ul style="list-style-type: none"> ▶ Check: <ul style="list-style-type: none"> - HCM is inserted properly. - Connections of the burner control. ▶ Replace burner control if necessary.
Internal error		328	Internal error (Mains voltage / frequency may be inconsistent)	<ul style="list-style-type: none"> ▶ Check the voltage and frequency.
		235	Incompatible HCM software version	<p>Revised HCM software requires latest version of control box to operate correctly</p> <ul style="list-style-type: none"> ▶ Replace the control box with the latest software. On the barcode label of the burner control the software version is indicated.
		356	Low mains voltage, (the voltage may be interrupted or inconsistent).	<ul style="list-style-type: none"> ▶ Check mains voltage.
		360	HCM invalid	<p>The inserted HCM does not correspond with the control box. HCM must be within the same appliance type.</p> <ul style="list-style-type: none"> ▶ Check the correct HCM is fitted. <ul style="list-style-type: none"> - HCM identification number found in Technical data table.
	A8	361	HCM invalid	<p>The inserted HCM does not correspond with the control box or HMI type.</p> <ul style="list-style-type: none"> ▶ Contact technical helpline.
		363	Ionisation measuring fault	<ul style="list-style-type: none"> ▶ Check heat cell earth wire continuity.
		356	Low mains voltage, (the voltage may be interrupted or inconsistent).	<ul style="list-style-type: none"> ▶ Check mains voltage.





Table 48

Display text	Fault code	Cause code	Description	Possible solution/check
	CC	800	Outdoor sensor defect (available when accessory outdoor sensor is connected)	<ul style="list-style-type: none"> ▶ Check: <ul style="list-style-type: none"> – Sensor harness and connector. – Operation, replace if necessary.
DHW sensor fault	A7	808	Domestic hot water sensor defect	<ul style="list-style-type: none"> ▶ Check: <ul style="list-style-type: none"> – Sensor harness and connector. – Operation, replace if necessary.
Pump error	A1	281	Pump stuck or running dry	<ul style="list-style-type: none"> ▶ Check: <ul style="list-style-type: none"> – Primary system water pressure. – For air in the system. – Circulation within heating system. – Wiring and operation of the pump, replace if necessary.
Temperature fault	E9	224	Flue or high limit thermostat activated (safety circuit)	<ul style="list-style-type: none"> ▶ Check: <ul style="list-style-type: none"> – Flue & high limit thermostat harness and connector. – Operation, replace if necessary. – Circulation within heating system. – Burner gasket for leakage of flue gasses, replace if necessary. – Heat exchanger for debris. – Air-gas ratio.
Temperature fault	D4	341	Primary flow temperatures rising too fast	<ul style="list-style-type: none"> ▶ Check: <ul style="list-style-type: none"> – Primary system water pressure. – For air in the system. – Circulation within heating system. – Wiring and operation of the pump and the respective sensors, replace if necessary.

Table 48

8.1.3 Factory Reset

To reset all settings on Boiler settings and Weather sensor settings back to the factory defaults:

- ▶ Press the  and  buttons for approximately 8 seconds to enter appliance menu function.
- ▶ Press the  button or the  button to reset all the menu settings to the factory settings.

This is confirmed on the display with a tick and the word “Reset”. after approximately 4 seconds the display returns to main screen.

8.2 Component resistance characteristics

8.2.1 Flow temperature NTC sensor

Resistance (Ω)	Temperature ($^{\circ}\text{C}$)	
	Measurement tolerance $\pm 10\%$	
35,975	0	
28,516	5	
22,763	10	
18,279	15	
14,772	20	
11,981	25	
9,786	30	
8,047	35	
6,653	40	
5,523	45	
4,608	50	
3,856	55	
3,243	60	
2,744	65	
2,332	70	
1,990	75	
1,704	80	
1,464	85	
1,262	90	
1,093	95	
950	100	

Table 49 Central heating flow sensors

8.2.2 DHW NTC sensor

Resistance (Ω)	Temperature ($^{\circ}\text{C}$)	
	Measurement tolerance $\pm 10\%$	
36,005	0	
28,540	5	
22,782	10	
18,294	15	
14,785	20	
11,991	25	
9,794	30	
8,054	35	
6,658	40	
5,527	45	
4,612	50	
3,859	55	
3,246	60	
2,747	65	
2,334	70	
1,991	75	
1,705	80	
1,465	85	
1,263	90	
1,094	95	
951	100	

Table 50 Domestic hot water sensors

8.2.3 Flue overheat thermostat

Normally closed thermostat	Resistance (Ω)	Temperature ($^{\circ}\text{C}$)
Opening temperature	3,500	≥ 112
Close temperature	6,500	≤ 111

Table 51 Flue overheat thermostat

8.2.4 Overheat thermostat

Normally closed thermostat	Resistance	Temperature ($^{\circ}\text{C}$)
Opening temperature	$\leq 50\text{M } \Omega$	≥ 120
Close temperature	5,000 Ω	≤ 119

Table 52 Overheat thermostat

8.2.5 Outdoor weather compensation sensor

Resistance (Ω)	Temperature ($^{\circ}\text{C}$)
$\geq 4,111$	-40
3,669	-35
3,218	-30
2,775	-25
2,360	-20
1,983	-15
1,650	-10
1,363	-5
1,122	0
922	5
759	10
624	15
515	20
427	25
354	30
296	35
247	40
207	45
≤ 174	50

Table 53 Outdoor weather compensation sensor

8.2.6 Gas valve resistances

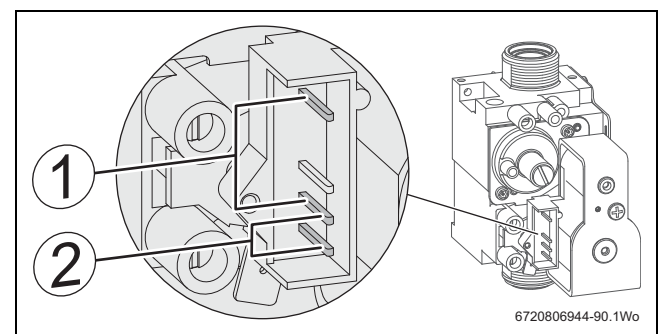
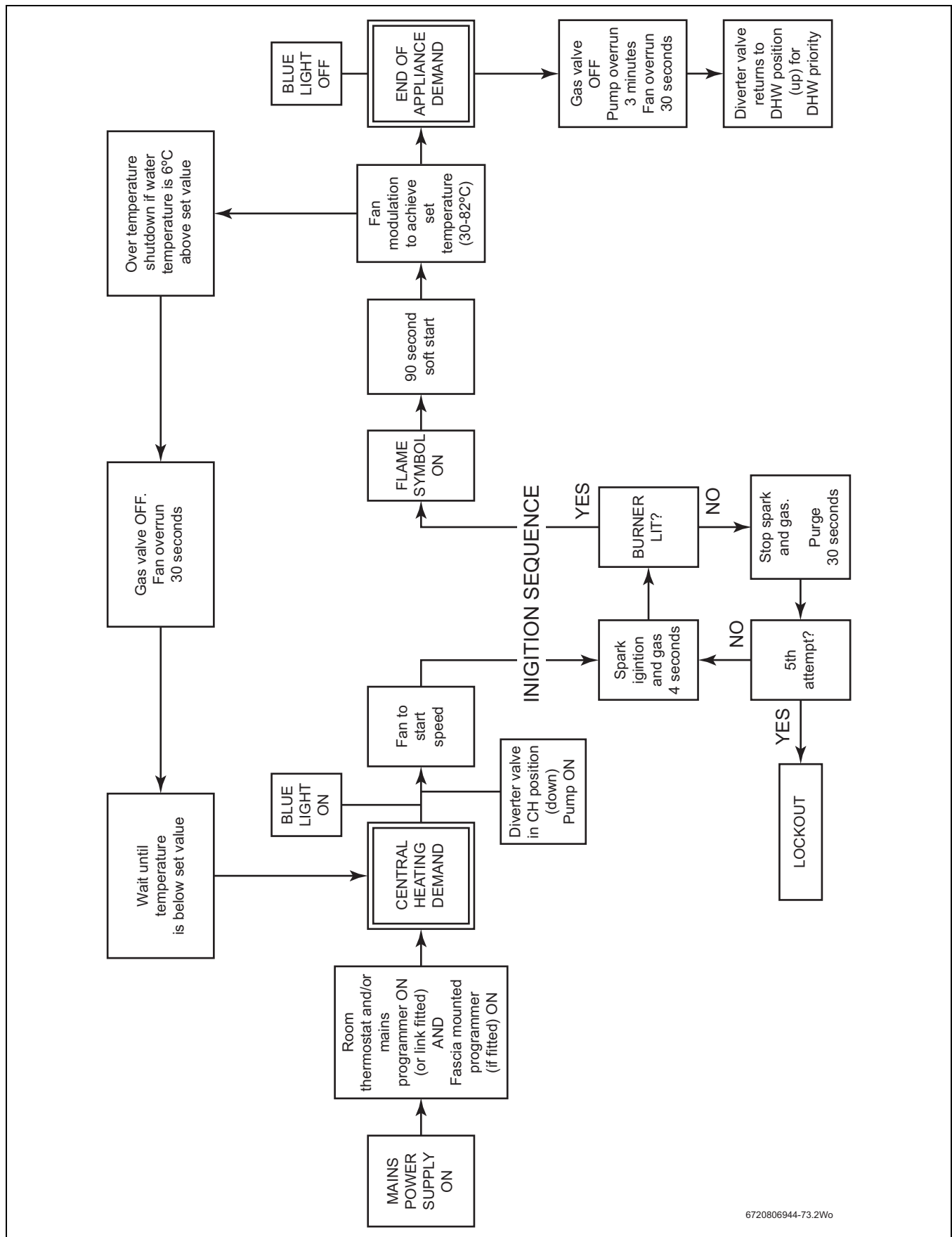

Fig. 104 Gas valve resistances

	Pins measured from top	Resistance (Ω)
1	First and third	6,100
2	Third and fourth	900

Table 54

8.3 Central heating function



6720806944-73.2Wo

Fig. 105 Central heating function

8.4 Preheat and DHW function

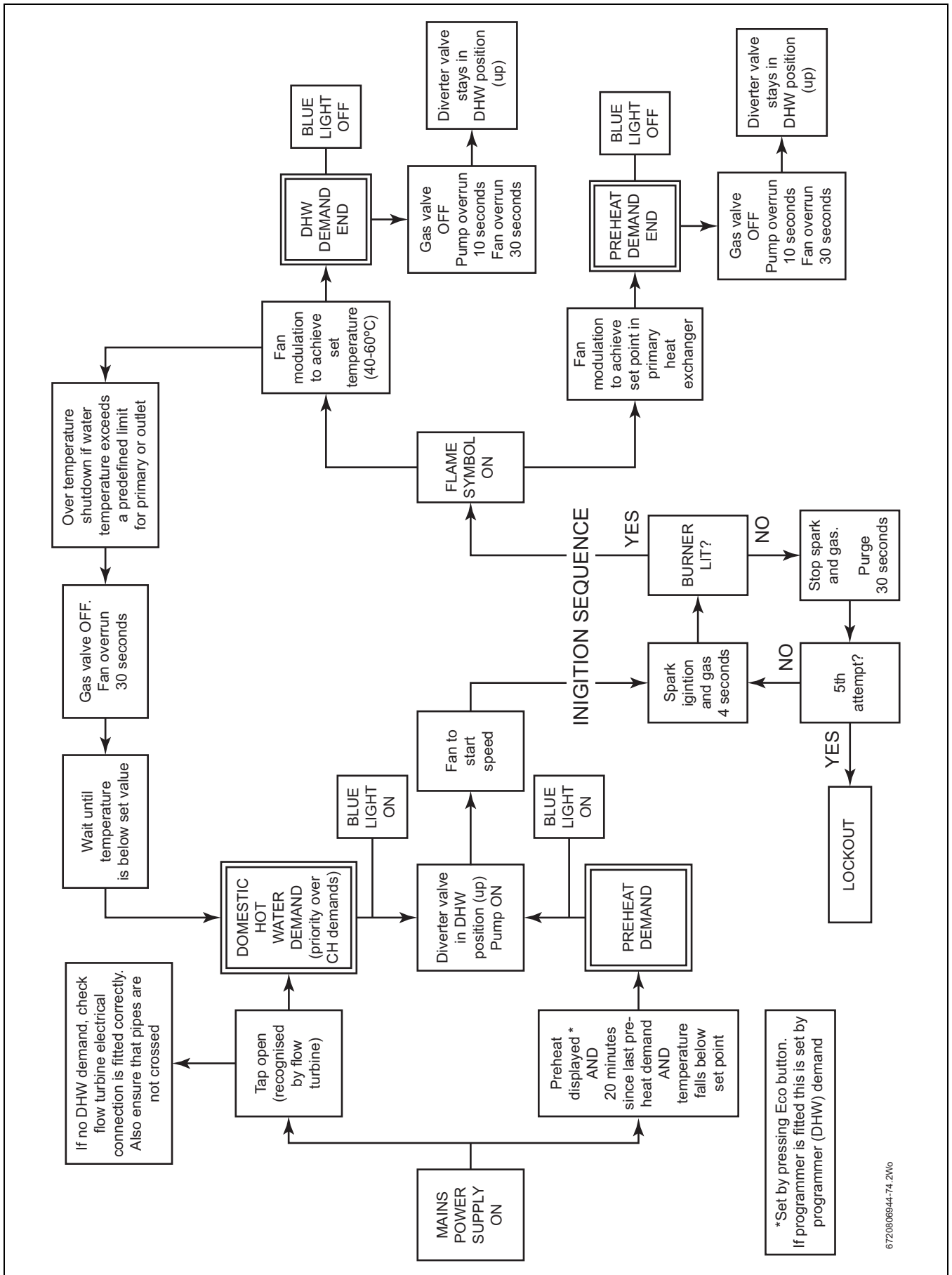

6720806944-74_2V6

Fig. 106 Preheat and DHW function

8.5 Protection function

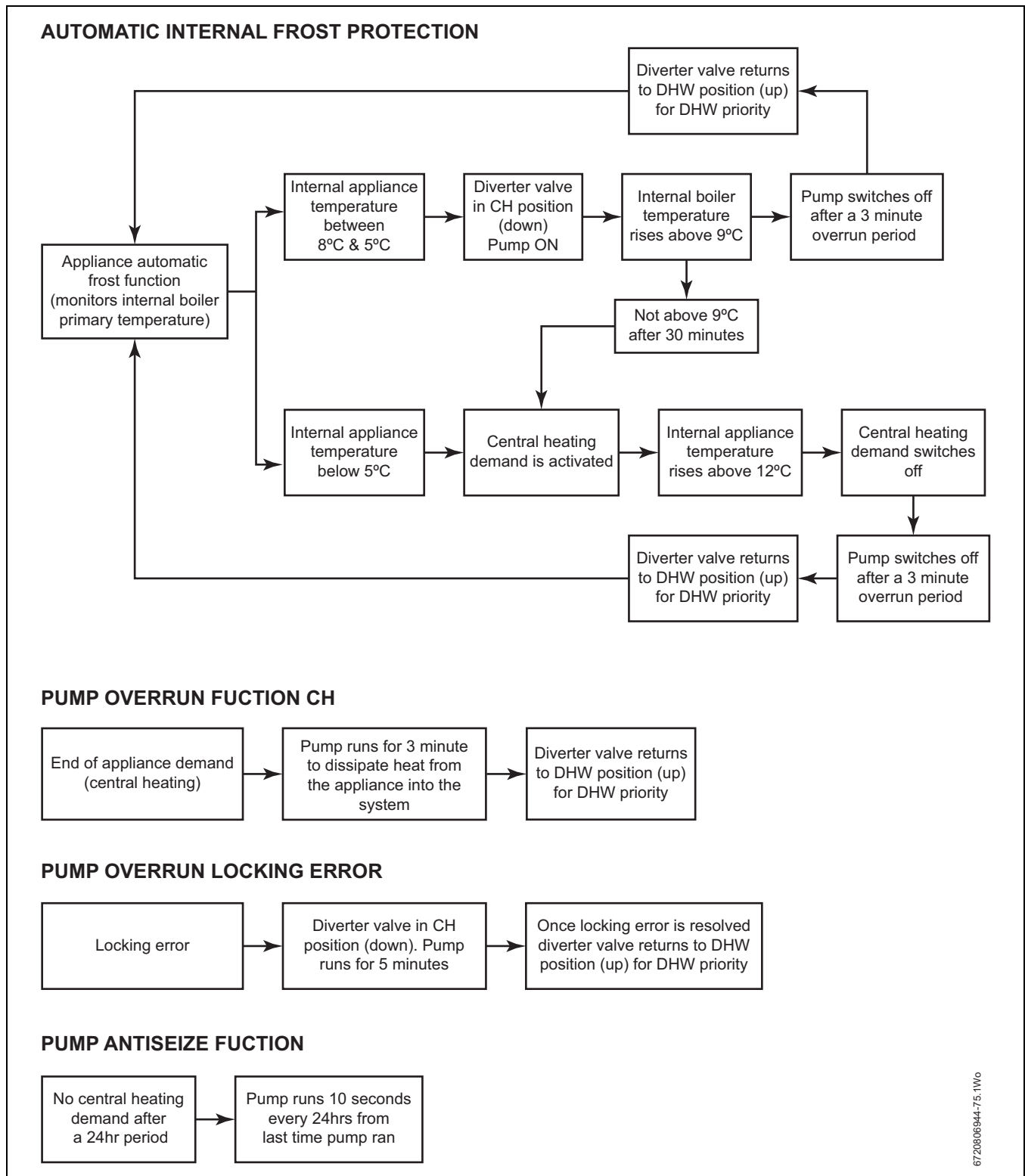

Fig. 107 Protection function

GAS BOILER SYSTEM COMMISSIONING CHECKLIST (for installations up to 70kW net input)

This Commissioning Checklist is to be completed in full by the competent person who commissioned the boiler as a means of demonstrating compliance with the appropriate Building Regulations and then handed to the customer to keep for future reference.

Failure to install and commission according to the manufacturer's instructions and complete this Benchmark Commissioning Checklist will invalidate the warranty. This does not affect the customer's statutory rights.

Customer name:				Telephone number:			
Address:							
Boiler make and model:							
Boiler serial number:							
Commissioned by (PRINT NAME):				Gas Safe register number:			
Company name:				Telephone number:			
Company address:							
				Commissioning date:			
To be completed by the customer on receipt of a Building Regulations Compliance Certificate*							
Building Regulations Notification Number (if applicable):							
CONTROLS (tick the appropriate boxes)							
Time and temperature control to heating	Room thermostat and programmer/timer	<input type="checkbox"/>	Programmable room thermostat	<input type="checkbox"/>			
	Load/weather compensation	<input type="checkbox"/>	Optimum start control	<input type="checkbox"/>			
Time and temperature control to hot water	Cylinder thermostat and programmer/timer	<input type="checkbox"/>	Combination Boiler	<input type="checkbox"/>			
Heating zone valves	Fitted	<input type="checkbox"/>	Not required	<input type="checkbox"/>			
Hot water zone valves	Fitted	<input type="checkbox"/>	Not required	<input type="checkbox"/>			
Thermostatic radiator valves	Fitted	<input type="checkbox"/>	Not required	<input type="checkbox"/>			
Automatic bypass to system	Fitted	<input type="checkbox"/>	Not required	<input type="checkbox"/>			
Boiler interlock			Provided	<input type="checkbox"/>			
ALL SYSTEMS							
The system has been flushed and cleaned in accordance with BS7593 and boiler manufacturer's instructions				Yes	<input type="checkbox"/>		
What system cleaner was used?							
What inhibitor was used?				Quantity	litres		
Has a primary water system filter been installed?				Yes	<input type="checkbox"/>	No	<input type="checkbox"/>
CENTRAL HEATING MODE measure and record:							
Gas rate	m ³ /hr	<input type="text"/>	OR	ft ³ /hr	<input type="text"/>		
Burner operating pressure (if applicable)	mbar	<input type="text"/>	OR Gas inlet pressure	mbar	<input type="text"/>		
Central heating flow temperature				°C	<input type="text"/>		
Central heating return temperature				°C	<input type="text"/>		
COMBINATION BOILERS ONLY							
Is the installation in a hard water area (above 200ppm)?				Yes	<input type="checkbox"/>	No	<input type="checkbox"/>
If yes, and if required by the manufacturer, has a water scale reducer been fitted?				Yes	<input type="checkbox"/>	No	<input type="checkbox"/>
What type of scale reducer has been fitted?							
DOMESTIC HOT WATER MODE Measure and Record:							
Gas rate	m ³ /hr	<input type="text"/>	OR	ft ³ /hr	<input type="text"/>		
Burner operating pressure (at maximum rate)	mbar	<input type="text"/>	OR Gas inlet pressure at maximum rate	mbar	<input type="text"/>		
Cold water inlet temperature				°C	<input type="text"/>		
Hot water has been checked at all outlets			Yes	Temperature	°C	<input type="text"/>	
Water flow rate				l/min	<input type="text"/>		
CONDENSING BOILERS ONLY							
The condensate drain has been installed in accordance with the manufacturer's instructions and/or BS5546/BS6798				Yes	<input type="checkbox"/>		
ALL INSTALLATIONS							
Record the following:	At max. rate:	CO	ppm	AND	CO/CO ₂	Ratio	<input type="text"/>
	At min. rate: (where possible)	CO	ppm	AND	CO/CO ₂	Ratio	<input type="text"/>
The heating and hot water system complies with the appropriate Building Regulations				Yes	<input type="checkbox"/>		
The boiler and associated products have been installed and commissioned in accordance with the manufacturer's instructions				Yes	<input type="checkbox"/>		
The operation of the boiler and system controls have been demonstrated to and understood by the customer				Yes	<input type="checkbox"/>		
The manufacturer's literature, including Benchmark Checklist and Service Record, has been explained and left with the customer				Yes	<input type="checkbox"/>		
Commissioning Engineer's Signature							
Customer's Signature							
(To confirm satisfactory demonstration and receipt of manufacturer's literature)							

*All installations in England and Wales must be notified to Local Authority Building Control (LABC) either directly or through a Competent Persons Scheme. A Building Regulations Compliance Certificate will then be issued to the customer.



SERVICE RECORD

It is recommended that your heating system is serviced regularly and that the appropriate Service Interval Record is completed.

Service Provider

Before completing the appropriate Service Record below, please ensure you have carried out the service as described in the manufacturer's instructions. Always use the manufacturer's specified spare part when replacing controls.

SERVICE 01					Date:
Engineer name:					
Company name:					
Telephone No:					
Gas safe register No:					
Record:	At max. rate:	CO	ppm	AND	CO ₂ %
	At min. rate: (Where Possible)	CO	ppm	AND	CO ₂ %
Comments:					
Signature					

SERVICE 02					Date:
Engineer name:					
Company name:					
Telephone No:					
Gas safe register No:					
Record:	At max. rate:	CO	ppm	AND	CO ₂ %
	At min. rate: (Where Possible)	CO	ppm	AND	CO ₂ %
Comments:					
Signature					

SERVICE 03					Date:
Engineer name:					
Company name:					
Telephone No:					
Gas safe register No:					
Record:	At max. rate:	CO	ppm	AND	CO ₂ %
	At min. rate: (Where Possible)	CO	ppm	AND	CO ₂ %
Comments:					
Signature					

SERVICE 04					Date:
Engineer name:					
Company name:					
Telephone No:					
Gas safe register No:					
Record:	At max. rate:	CO	ppm	AND	CO ₂ %
	At min. rate: (Where Possible)	CO	ppm	AND	CO ₂ %
Comments:					
Signature					

SERVICE 05					Date:
Engineer name:					
Company name:					
Telephone No:					
Gas safe register No:					
Record:	At max. rate:	CO	ppm	AND	CO ₂ %
	At min. rate: (Where Possible)	CO	ppm	AND	CO ₂ %
Comments:					
Signature					

SERVICE 06					Date:
Engineer name:					
Company name:					
Telephone No:					
Gas safe register No:					
Record:	At max. rate:	CO	ppm	AND	CO ₂ %
	At min. rate: (Where Possible)	CO	ppm	AND	CO ₂ %
Comments:					
Signature					

SERVICE 07					Date:
Engineer name:					
Company name:					
Telephone No:					
Gas safe register No:					
Record:	At max. rate:	CO	ppm	AND	CO ₂ %
	At min. rate: (Where Possible)	CO	ppm	AND	CO ₂ %
Comments:					
Signature					

SERVICE 08					Date:
Engineer name:					
Company name:					
Telephone No:					
Gas safe register No:					
Record:	At max. rate:	CO	ppm	AND	CO ₂ %
	At min. rate: (Where Possible)	CO	ppm	AND	CO ₂ %
Comments:					
Signature					

SERVICE 09					Date:
Engineer name:					
Company name:					
Telephone No:					
Gas safe register No:					
Record:	At max. rate:	CO	ppm	AND	CO ₂ %
	At min. rate: (Where Possible)	CO	ppm	AND	CO ₂ %
Comments:					
Signature					

SERVICE 10					Date:
Engineer name:					
Company name:					
Telephone No:					
Gas safe register No:					
Record:	At max. rate:	CO	ppm	AND	CO ₂ %
	At min. rate: (Where Possible)	CO	ppm	AND	CO ₂ %
Comments:					
Signature					

*All installations in England and Wales must be notified to Local Authority Building Control (LABC) either directly or through a Competent Persons Scheme. A Building Regulations Compliance Certificate will then be issued to the customer.



Worcester, Bosch Group
Cotswold Way, Warndon, Worcester WR4 9SW.
Tel. 0330 123 9559

Worcester, Bosch Group is a brand name of Bosch Thermotechnology Ltd.
worcester-bosch.co.uk

6 720 806 944 (2016/07)

WORCESTER, BOSCH GROUP:

TECHNICAL SUPPORT:	0330 123 3366
APPOINTMENTS:	0330 123 9339
SPARES:	0330 123 9779
LITERATURE:	0330 123 9119
TRAINING:	0330 123 0166
SALES:	0330 123 9669



WORCESTER
Bosch Group