

ZANUSSI

Ceramic glass hob
ZKF 641 X

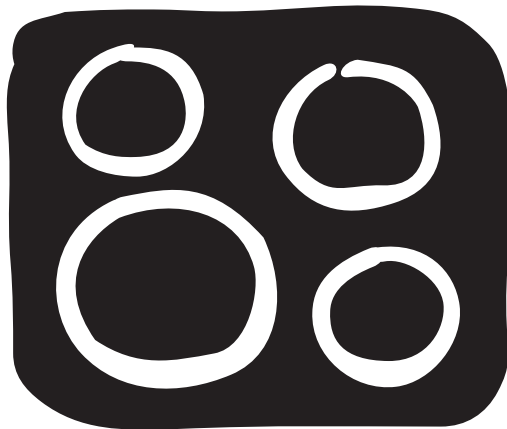

Installation and Operating Instructions



ATTENTION INSTALLER

The cable used to connect the appliance to the mains electricity supply **MUST** have a minimum temperature rating of V90HT for the complete distance of cable run under the hob.

Surface temperature exceeds 95degC. To avoid a hazard, under bench access must be restricted Refer to the Installation instructions.

WARNING

If the surface is cracked, switch off the appliance to avoid the possibility of electric shock.

The appliance is not intended for use by young children or infirm persons without supervision.

Never leave the appliance unattended when in use.

Young children should be supervised to ensure that they do not play with the appliance.

Do not touch hot surfaces. Allow to cool before cleaning.

This product has not been designed for any uses other than those specified in this booklet.

Dear customer,

Please read these operating instructions carefully. Pay particular attention to the section “Safety information” on the first few pages. Please retain these operating instructions for later reference. Pass them on to possible new owners of the appliance.

The following symbols are used in the text:



Safety instructions

Warning: Information concerning your personal safety.

Important: Information on how to avoid damaging the appliance.



Information and practical tips



Environmental information

1. These numbers indicate step by step how to use the appliance.

2....

3....

These operating instructions contain information on steps you can take yourself to rectify a possible malfunction. Refer to the section “What to do if...”.

Contents

Operating Instructions	5
Safety	5
Disposal	6
The Key Features of Your Appliance	6
Description of the Appliance	7
Cooking zones and control panel	7
Before Using for the First Time	8
Initial Cleaning	8
Operating the Hob	8
Ring Switches	8
Cooking on the Zones	8
Residual heat indicator	9
Uses, Tables and Tips	10
Pans	10
Settings for Cooking on the Zones	11
Cleaning and Care	12
Hob	12
Hob Frame	13
What to do if	14
Rectifying faults	14
Installation Instructions	15
Technical Data	15
Regulations, Standards, Directives	15
Safety Instructions for the Installer	15
Electrical Connection	16
Rating Plate	16
Assembly	17
Service	19

Operating Instructions

Safety

The safety aspects of this appliance comply with accepted technical standards and the German Appliance Safety Law. However, as manufacturers we also believe it is our responsibility to familiarise you with the following safety instructions.

Electrical Safety

- The installation and connection of the new appliance must only be carried out by qualified personnel.
- Repairs to the appliance are only to be carried out by approved service engineers. Repairs carried out by inexperienced persons may cause injury or serious malfunctioning. If your appliance needs repairing, please contact your local customer center or your dealer.

 Please follow these instructions, otherwise the warranty will not cover any damage that may occur.

- Flush-mounted appliances may only be operated following installation in suitable installation cabinets and workplaces which conform to the relevant standards. This ensures sufficient protection against contact for electrical units as required by the VDE [Association of German Electrical Engineers].
- If your appliance malfunctions or if fractures, cracks or splits appear:
 - switch off all cooking zones,
 - disconnect the hob from the electricity supply.

Child Safety

The cooking zones will become hot when you cook. Therefore, always keep small children away from the appliance.

The appliance is not intended for use by young children or infirm persons without supervision.

Young children should be supervised to ensure that they do not play with the appliance.

Safety During Use

- This appliance may only be used for normal cooking and frying in the home. It is not designed for commercial or industrial purposes.
- Do not use the hob to heat the room.
- Take care when plugging electric appliances into mains sockets near the hob. Connection leads must not come into contact with the hot surface.

- Overheated fats and oils catch fire quickly. You should supervise cooking when preparing foods in fat or oil (e.g. chips).
- Switch off the cooking zones after use.

Safety When Cleaning

- For safety reasons do not clean the appliance with a steam jet or high pressure cleaner.
- Clean the hob in accordance with the maintenance and cleaning instructions in this manual.

To Avoid Damaging Your Appliance

- Do not use the hob as a work surface or for storage.
- Do not operate the cooking zones when there is no pan or the pans are empty.
- Ceramic glass is insensitive to temperature shock and very robust; however it is not unbreakable. Especially sharp and hard objects that fall on the cooking surface can damage it.
- Do not use cast iron pans or pans with a rough, burred or damaged base. Scratching may occur if the pans are slid across the surface.
- Do not place any pans on the hob frame. Scratching and damage to the paint may occur.
- Make sure that no acidic liquids, e.g. vinegar, lemon or descaling agents, are spilt onto the hob frame, since these cause dull spots.
- If sugar or a preparation with sugar comes into contact with the hot cooking zone and melts there it must be cleaned off immediately with a scraper while it is still hot. If it cools, the surface may be damaged when it is removed.
- Keep all items and materials that can melt away from the ceramic glass surface, e.g. plastics, aluminium foil, or oven foils. If something of this nature should melt onto the ceramic glass surface, it must also be removed immediately using the scraper.
- It is recommended that pans with aluminium or copper bases NOT be used as metallic discolouring and pitting may occur on the glass ceramic surface.

Disposal

Disposing of the packaging material

All materials used can be fully recycled.

Plastics are marked as follows:

- >PE< for polyethylene, as used for the outer wrapping and the bags inside.
- >PS< for polystyrene foam, e.g., as used for the padding materials. They are completely free of CFCs.

Disposal of old appliances



Warning: Before disposing of old appliances please make them inoperable so that they cannot be the source of danger.

To do this, disconnect the appliance from the mains supply and remove the mains lead.

To protect the environment, it is important that worn out appliances are disposed of in the correct manner.

- The appliance must not be disposed of with household rubbish.
- You can obtain information about collection dates or public refuse disposal sites from your local refuse department or council.

The Key Features of Your Appliance

- **Ceramic glass cooking surface:** The appliance has a ceramic glass cooking surface and 4 rapid response cooking zones. The particularly powerful radiant heater elements significantly shorten the amount of time taken for the zones to heat up.
- **Cleaning:** The advantage of the ceramic glass cooking surface is its easy cleaning. The smooth surface is easy to keep clean (see section: "Cleaning and care").
- **Residual heat indicator:** The residual heat indicator lights up if the cooking zone becomes so hot that there is a risk of burning.

Description of the Appliance

Cooking zones and control panel

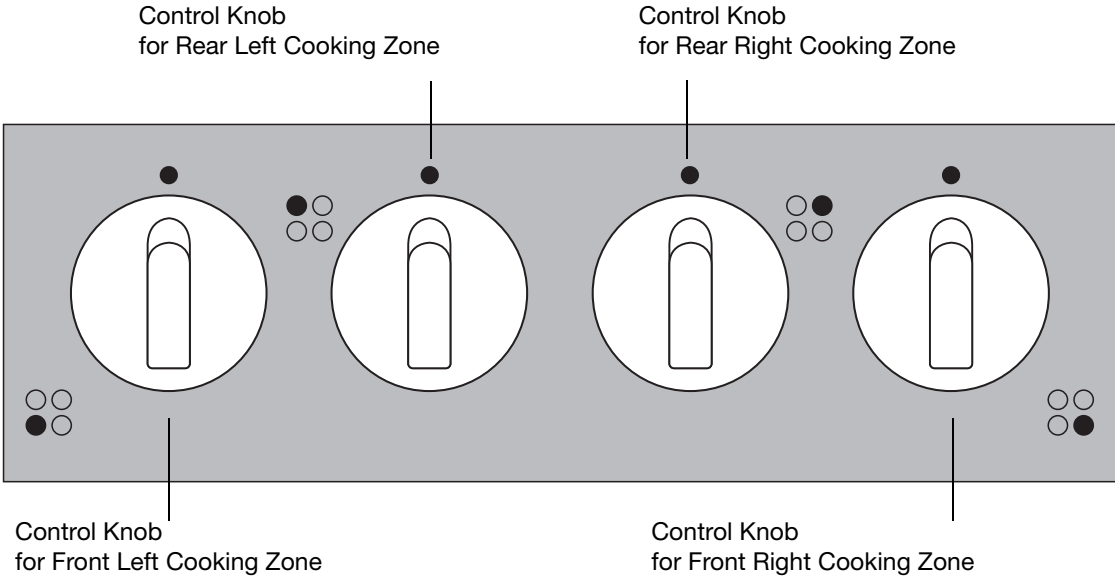
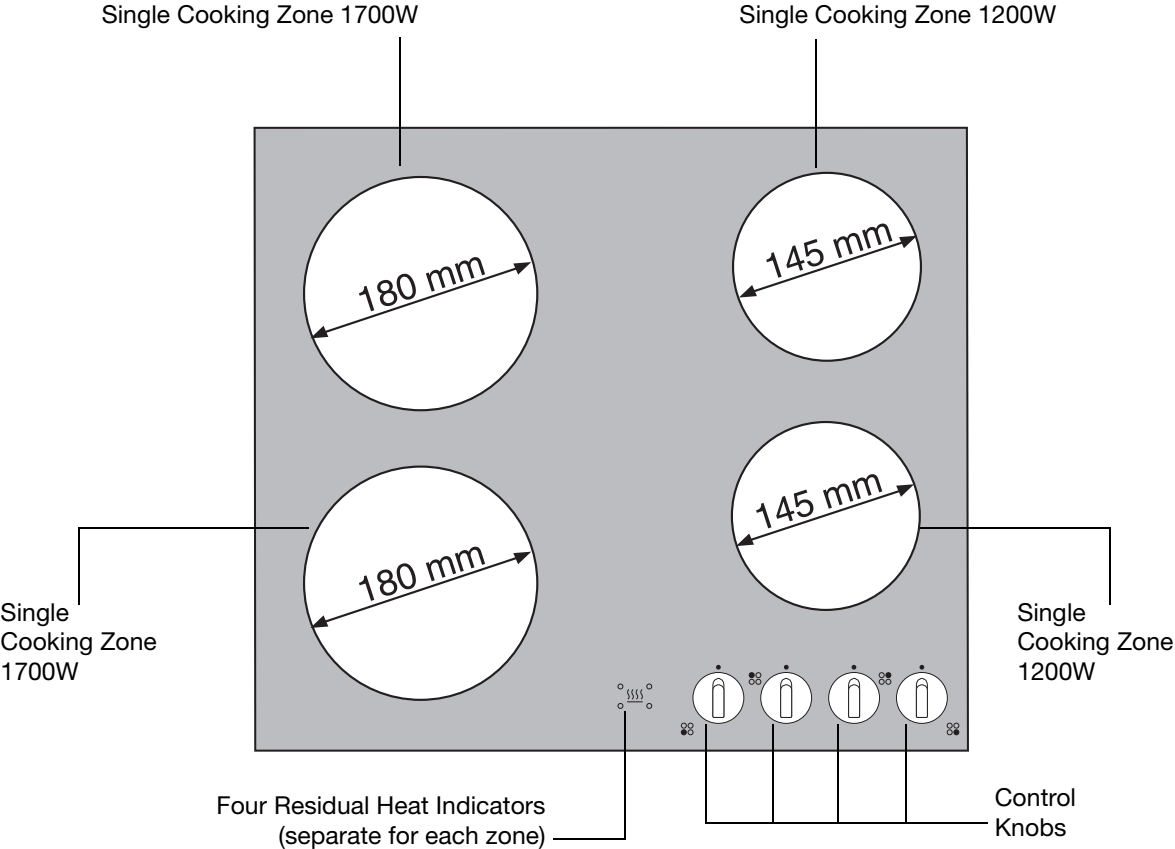

Before Using for the First Time

Initial Cleaning

Wipe the ceramic glass surface with a damp cloth.



Important: Do not use any caustic, abrasive cleaners! The surface could be damaged.

Operating the Hob



When a cooking zone is switched on, it may hum briefly. This is a characteristic of all ceramic glass cooking zones and does not impair either the function or the life of the appliance.

Ring Switches

- The heat settings are continuously variable between settings 1-10.

1 =lowest power

10 =highest power

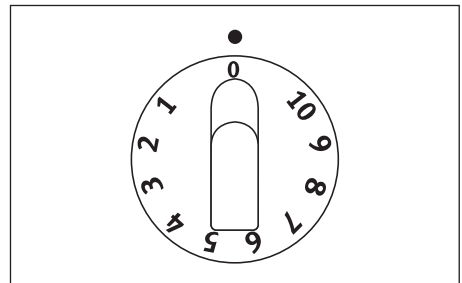

Cooking on the Zones

- Select a high setting for heating up / browning.

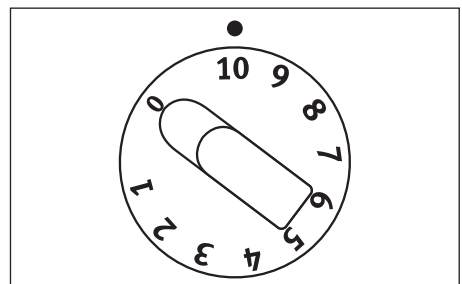

- As soon a steam starts to form or the oil is hot, turn back to the heat setting necessary for further cooking.

- To stop cooking, turn back to the zero position.



Switch off the cooking zone approx. 5-10 minutes before the end of the cooking to make use of the residual heat. Doing this will save electricity.

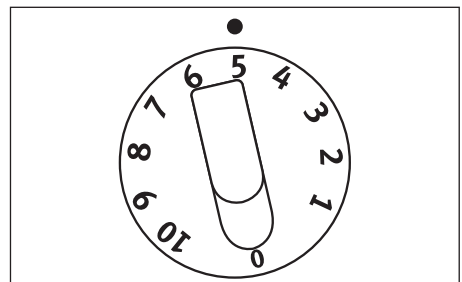

Residual heat indicator

The ceramic cooking zone is equipped with a residual heat indicator, a control lamp is allocated to each cooking zone. This lights up as soon the corresponding cooking zone is hot and warns against inadvertent contact.

The residual heat indicator only goes out when the cooking zone has cooled down even when the cooking zone is switched Off.



You can use the residual heat for melting and keeping food warm.



Important! As long as the residual heat indicator is illuminated, there is a risk of burns.



Important! If the power supply is interrupted the residual heat indicator also go out and information about residual heat will no longer be available. However, it is still possible to burn yourself. This can be avoided by being particularly attentive.

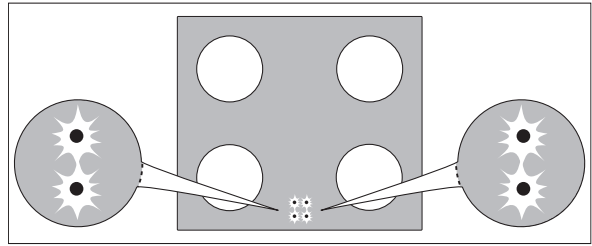

Uses, Tables and Tips

Pans

The better the pan, the better the results.

- You can recognise good pans by their bases. The base should be as thick and flat as possible.
- Pay particular attention when buying new pans to the diameter of the base. Manufacturers often give only the diameter of the upper rim.
- Pots with aluminium or copper bases can cause metallic discolouring on the glass ceramic surface, which is very difficult or impossible to remove.
- Do not use cast iron pans or pans with a rough, burred or damaged base. This can produce permanent scratching if the pan is slid across the surface.
- When cold, pan bases are normally bowed slightly inwards (concave). They should never be bowed outwards (convex).
- If you wish to use special types of pan (e.g. a pressure cooker, simmering pan, wok, etc.), please observe the manufacturer's instructions.

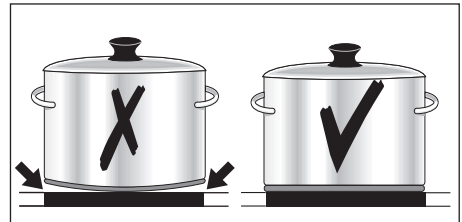

Energy saving tips

You can save valuable energy by observing the following points:

- Always position pots and pans before switching on the cooking zone.
 - Dirty cooking zones and pan bases increase power consumption.
 - Whenever possible always position the lids firmly on pots and pans to cover completely.
 - Switch off the cooking zones before the end of the cooking time to use the residual heat such as to keep foods warm or for melting.
-
- The base of the pan should be the same size as the cooking zone.
 - Using a pressure cooker reduces cooking times by up to 50%.

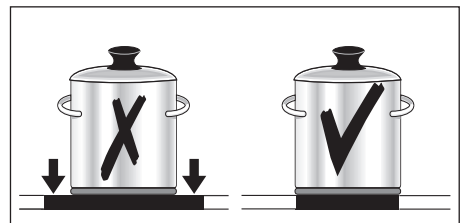
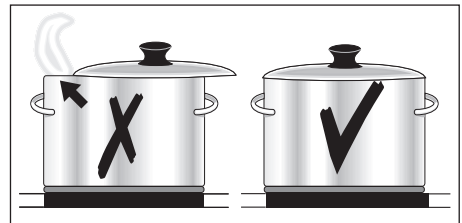

Settings for Cooking on the Zones

The setting position required for cooking processes is dependent on the quality of the pots and on the type and amount of the food.

Heat setting	Cooking method	Examples
9-10	Parboiling	Starting of cooking and roasting, cooking of large quantities of liquid, then switch-back to appropriate setting
8-9	Frying Quick frying	French fries, pan-cakes Fillet of pork and beef, steaks goulash
7-8	Roasting Frying without crust	Frying of meat, schnitzel, cutlets, meat-balls, sausages, liver, fish-fillet in deep fat, Frying eggs or chops
5-6	Boiling Braising	Boiled potatoes, stews, soups, hot-pot, sauces in large quantities
4-5	Simmering Stewing	Simmering of vegetables, braising of meat, lightly cooking small amount of fruit with little liquid
3-4	Gentle simmering	Simmering of rice and food with milk (sometimes stirring), Stewing of smaller amount of potatoes or vegetables, Warming up of prepared meal
1-2	Melting	Omelette, fried eggs, Hollandaise sauce, Keeping warm a meal or small amount of hot-pot Melting of butter, chocolate, gelatine.
0		Residual heat, OFF-position

 When heating up or frying, we recommend heat setting "10", and then continue cooking foods at an appropriate lower heat setting.

Cleaning and Care

Hob



Important: Cleaning agents must not come into contact with the **hot** ceramic glass surface! All cleaning agents must be removed with plenty of clean water after cleaning because they can have a caustic effect when the rings are next heated!

Do not use any aggressive cleaners such as grill or oven sprays, coarse scourers or abrasive pan cleaners.



Clean the ceramic glass surface after each use when it is warm to the touch or cold. This will avoid spillages becoming burnt on.

Remove scale and water marks, fat spots and discolouration with a metallic shimmer using a commercially available ceramic glass or stainless steel cleaner.

Light Soiling

1. Wipe the ceramic glass surface with a damp cloth and a little washing up liquid.
2. Then rub dry with a clean cloth. Remnants of cleaner must not be left on the surface.
3. Thoroughly clean the entire ceramic glass cooking surface once a week with a commercially available ceramic glass or stainless steel cleaner.
4. Then wipe the ceramic glass surface using plenty of clean water and rub dry with a clean fluff-free cloth.

Stubborn Soiling

1. To remove food that has boiled over or stubborn splashes, use a glass scraper.
2. Place the glass scraper at an angle to the ceramic glass surface.
3. Remove soiling by sliding the blade.

i You can obtain glass scrapers and ceramic glass cleaners from specialist retailers.

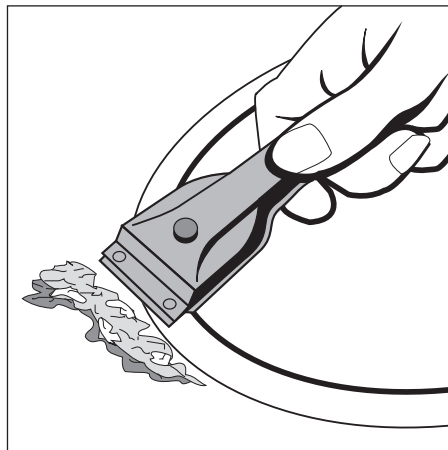

Problem Dirt

1. Remove burnt-on sugar, melted plastic, aluminium foil or other meltable materials with a glass scraper **immediately and while still hot**.

! **Important:** There is a risk of burning yourself when the glass scraper is used on a hot cooking zone!

2. Then clean the hob normally when it has cooled down.

i If the cooking zone on which something has melted has already cooled down, warm it up again for cleaning. Scratches or dark marks on the ceramic glass surface, caused for example by a pan base with sharp edges, cannot be removed. However, they do not impair the function of the hob.

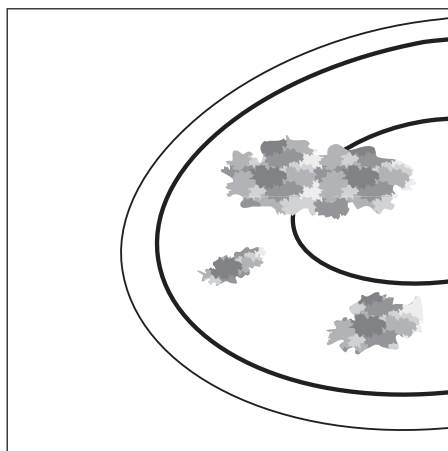

Hob Frame

! **Important!** Do not put vinegar, lemon-juice or scale removers on the hob frame, otherwise dull spots will appear.

1. Wipe the frame with a damp cloth and a little washing up liquid.
2. Soften dried dirt with a wet cloth. Then wipe off and rub dry.

What to do if ...

Rectifying faults

It is possible that faults have been caused by a minor error, which you can correct yourself with the help of the following instructions. Do not attempt any further repairs if the following instructions do not help in each specific case.



Warning! Repairs to the appliance are only to be carried out by approved service engineers. Improperly effected repairs may result in considerable risk to the user. If your appliance needs repairing, please contact your specialist dealer or customer service.

What to do when ...

... the cooking zone does not function?

Check whether

- the fuses in the house installation (fuse box) are intact. If the fuses switch off, or blow, several times, please call a qualified electrician.
- the corresponding cooking zone is switched ON and the desired heat setting has been selected.
- for cooking zones with several rings, the desired ring has been switched ON.

If a service engineer's visit is necessary due to incorrect operation, the service visit will not be free of charge, even during the guarantee period.

Installation Instructions



Important! The new appliance may only be installed and connected by **qualified personnel**.

Please observe this instruction, otherwise the warranty will not cover any damage that may occur.



This appliance complies with the following EU Directives:

- 73/23/EWG dated 19.02.1973 (Low Voltage Directive)
- 89/336/EWG dated 03.05.1989 (EMC Directive including Amending Directive 92/31/EWG).

Technical Data

Appliance dimensions

Width	572 mm
Depth	502 mm
Height	47 mm

Worktop cut-out dimensions

Width	560 mm
Depth	490 mm
Corner radius	R5

Cooking rings

Position	Diameter	Power
Front left	180mm	1700W
Rear left	180mm	1700W
Rear right	145mm	1200W
Front right	145mm	1200W

Connection voltage 230 V ~ 50Hz

Maximum connected load power 5,8kW

Regulations, Standards, Directives

This appliance meets the following standards:

- EN 60 335-1 and EN 60 335-2-6 relating to the safety of electrical appliances for household use and similar purposes and
- EN 60350, or DIN 44546 / 44547 / 44548 relating to the operating features of electric cookers, hobs, ovens, and grills for household use.
- EN 55014-2
- EN 55014
- EN 61000-3-2
- EN 61000-3-3
- relating to basic requirements for electro-magnetic compatibility protection (EMC).



Safety Instructions for the Installer

- A device must be provided in the electrical installation which allows the appliance to be disconnected from the mains at all poles with a contact opening width of at least 3 mm.
Suitable isolation devices include line protecting cut-outs, fuses (screw type fuses are to be removed from the holder), earth leakage trips and contactors.
- In respect of fire protection, this appliance corresponds to EN 60 335-2-6. This type of appliance may be installed with a high cupboard or wall on one side.
- Drawers may not be fitted underneath the hob.
- The installation must guarantee shock protection.
- The kitchen unit in which the appliance is fitted must satisfy the stability requirements of DIN 68930.
- For protection against moisture, all cut surfaces are to be sealed with a suitable sealant.
- On tiled work surfaces, the joints in the area where the hob sits must be completely filled with grout.
- Ensure that the seal is correctly seated against the work surface without any gaps. Additional silicon sealant must not be applied; this would make removal more difficult when servicing.
- The hob must be pressed out from below when removed.

For Australia:

- CAUTION: The surface temperature exceeds 95°C. To avoid a hazard, underbench access must be restricted.
- The cable used to connect the appliance to the mains electricity supply must have a minimum temperature rating of V90HT for the complete distance of cable run under the hob.

Electrical Connection

Before connecting, check that the nominal voltage of the appliance, that is the voltage stated on the rating plate, corresponds to the available supply voltage. The rating plate is located on the lower casing of the hob.

The heating element voltage is AC230V~. The appliance also works perfectly on networks with AC220V~ or AC240V~.

The hob is to be connected to the mains using a device that allows the appliance to be disconnected from the mains at all poles with a contact opening width of at least 3 mm, eg. automatic line protecting cut-out, earth leakage trips or fuse.

A cable with minimum temperature rating of V90HT or one with a higher grade must be used as the mains connecting cable.

The connection must be carried out as shown in the diagram. The connecting links should be fitted according to the appropriate connection diagram. The earth lead is connected to terminal ⊕. The earth lead must be longer than leads carrying electric current.

The cable connections must be made in accordance with regulations and the terminal screws tightened securely.

Finally, the connecting cable is to be secured with the mains cable cleat and the covering closed by pressing firmly (lock into place).

Before switching on for the first time, any protective foil or stickers must be removed from the glass ceramic surface.



Once connected to the mains supply check that all cooking zones are ready for use by briefly switching each on in turn at the maximum setting.

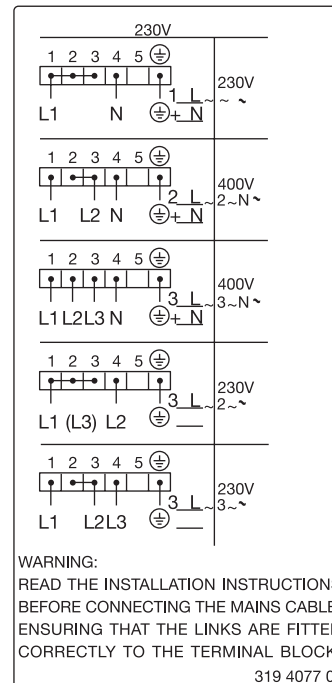

Rating Plate

Modell	ZKF 641 X	Prod.Nr.	949591276
Typ	PEE2 014	230-240 V AC 50 Hz	
Made in Germany	Ser.Nr.	5,8-6,0 kW	
ZANUSSI		CE	

Assembly

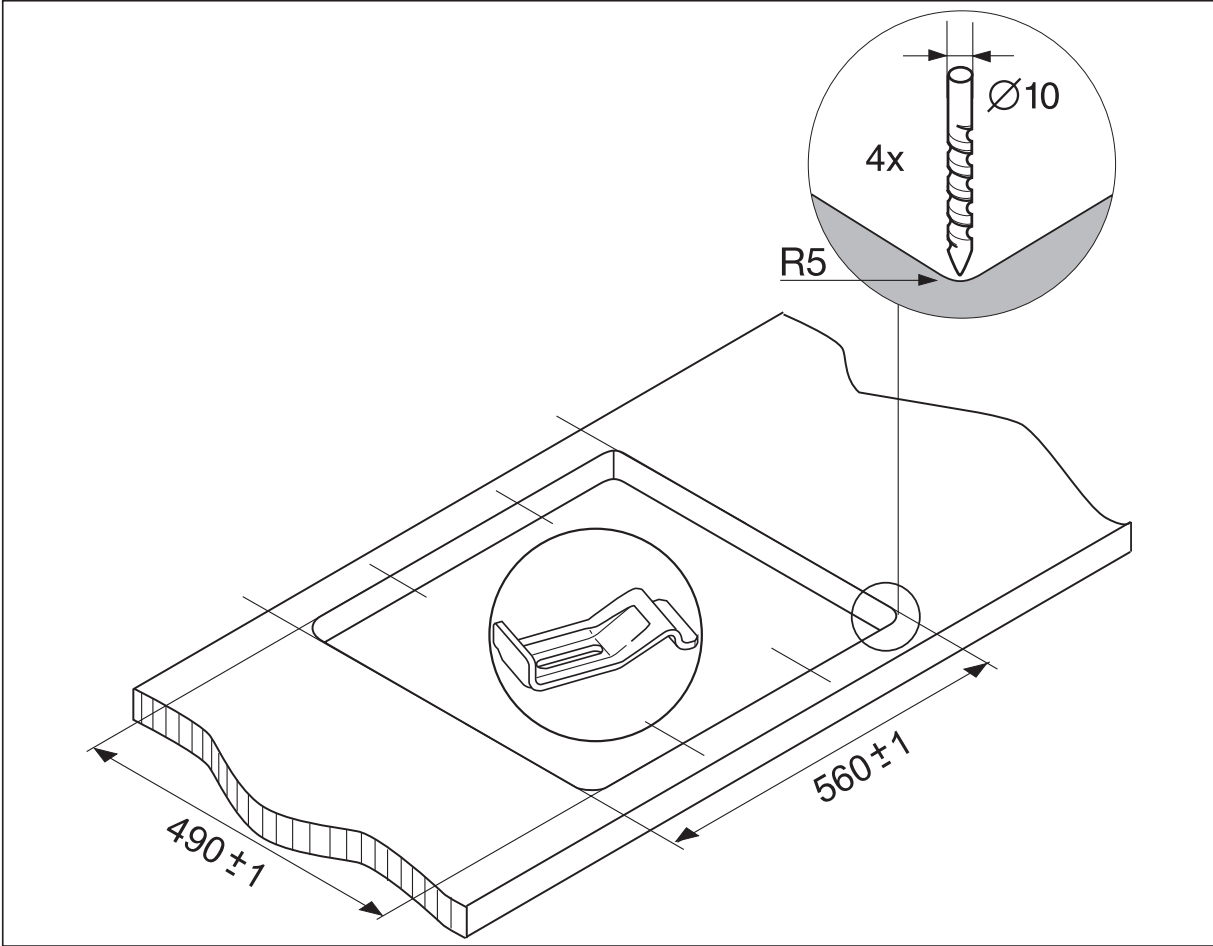
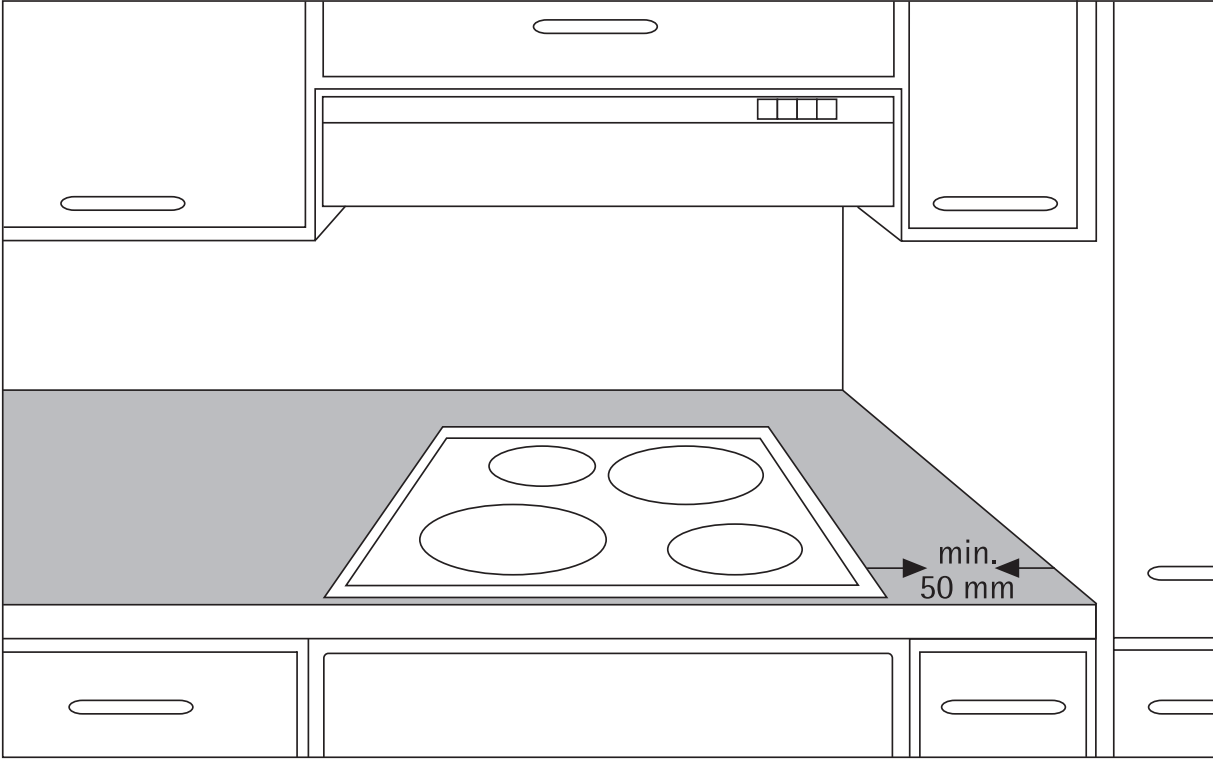

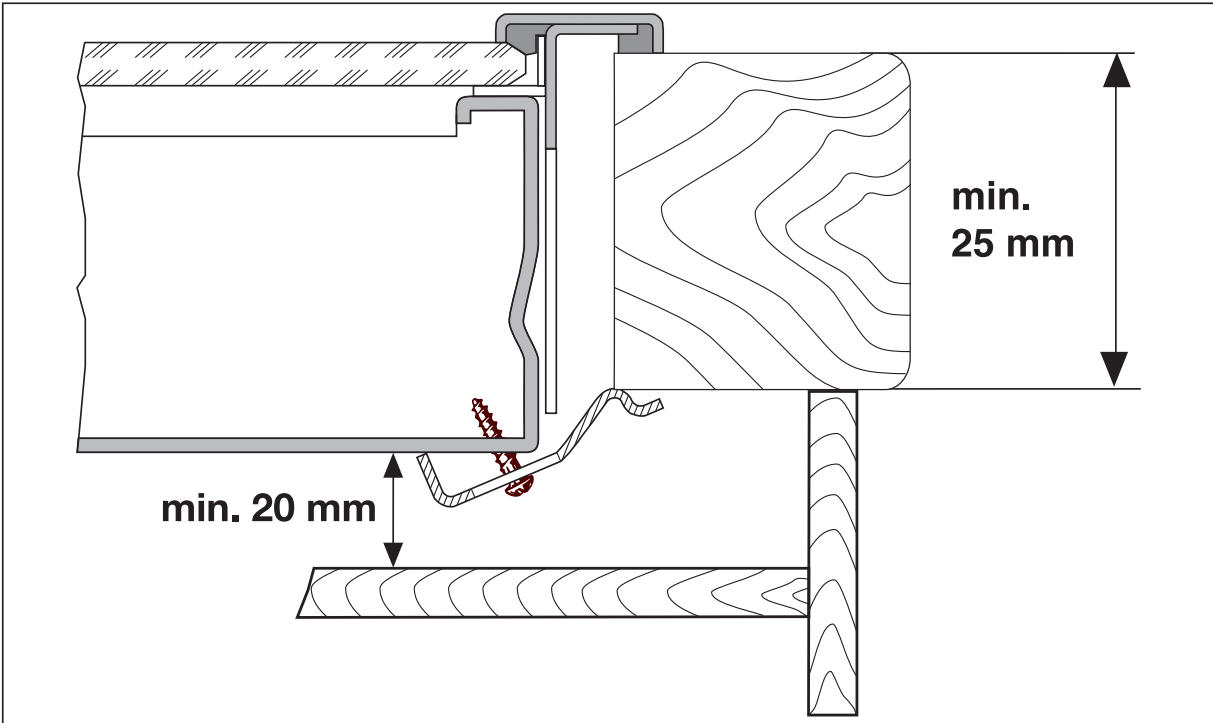
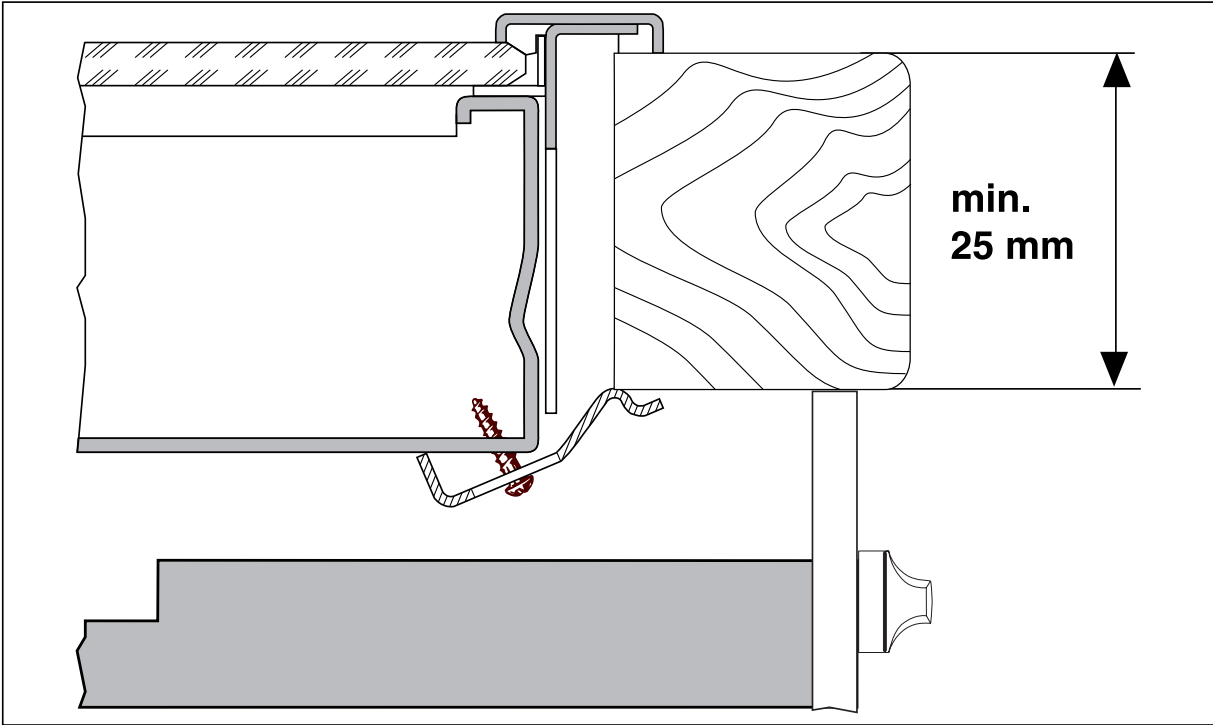

Service

In the “What to do if ...” section a number of malfunctions are listed that you can rectify yourself. Look there first if a fault occurs.

Is it a technical fault?

If so, please contact your customer service centre.

In Australia **warranty, service and spare parts** are handled by Electric Blue Pty Ltd. For installations and Service phone from anywhere in Australia

13 63 39

Always prepare in advance for the discussion. This will make diagnosis of the problem easier and also make it easier to decide if a customer service visit is necessary:

Please make a note of the following information as accurately as possible:

- What form does the fault take?
- Under what circumstances does the fault occur?

Prior to the telephone call it is important that you make a note of the following appliance code numbers that are given on the rating plate:

- model description,
- PNC code (9 digits),
- S No code (8 digits).

We recommend that you record the code numbers here so that you always have them to hand:

Model:

PNC:

S-No:

When do you incur costs even during the warranty period?

- if you could have remedied the fault yourself using the fault table (see section “What to do if ...”),
- if the customer service technician has to make several journeys because he was not provided with all the relevant information before his visit and therefore, foreexample, has to fetch spare parts. These multiple trips can be avoided if you prepare your phone call as described above.

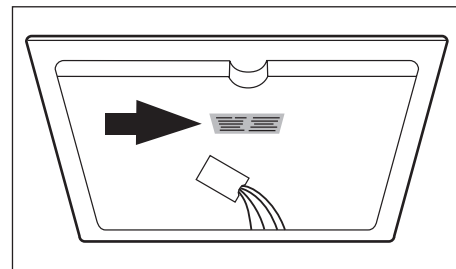

822 924 171-B-140503-02

Subject to change without notice

 **The Electrolux Group. The world's No.1 choice.**

The Electrolux Group is the world's largest producer of powered appliances for kitchen, cleaning and outdoor use. More than 55 million Electrolux Group products (such as refrigerators, cookers, washing machines, vacuum cleaners, chain saws and lawn mowers) are sold each year to a value of approx. USD 14 billion in more than 150 countries around the world.